



## Trunk 2000™

T-2000

### Installation and Operation Manual

Installation, Operation, and Service Information

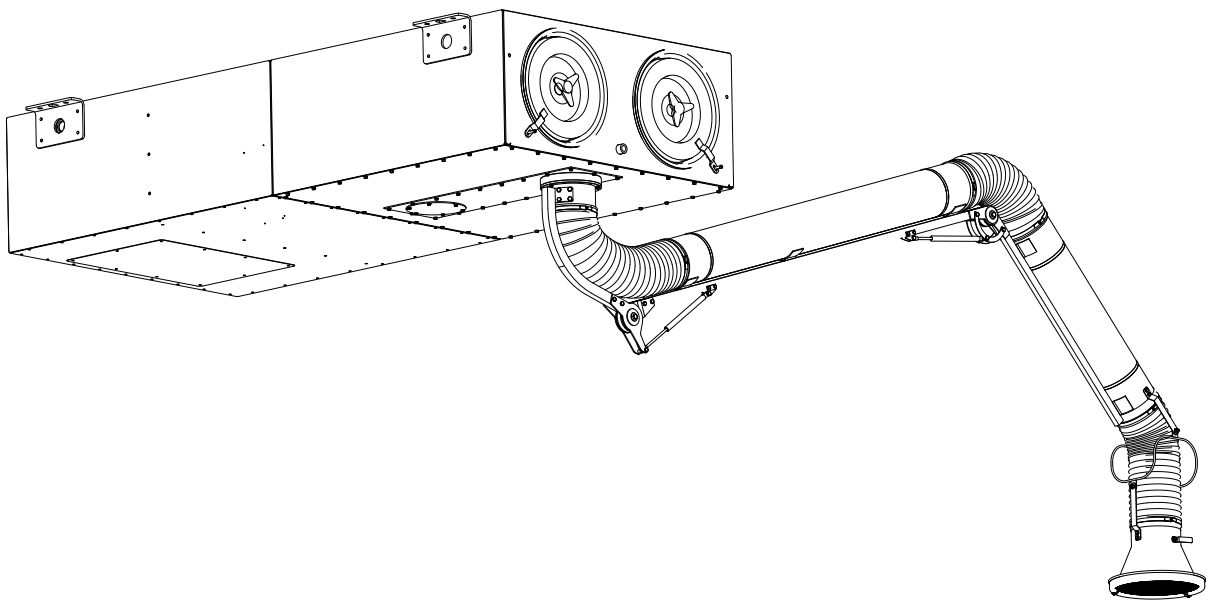

This manual is property of the owner. Leave with the unit when set-up and start-up are complete. Donaldson Company reserves the right to change design and specifications without prior notice.

Illustrations are for reference only as actual product may vary.



**This is the safety alert symbol. It is used to alert you to potential personal injury hazards. Obey all safety messages that follow this symbol to avoid possible injury or death.**

**WARNING**

Process owners/operators have important responsibilities relating to combustible hazards. Process owners/operators must determine whether their process creates combustible dust, fume, or mist. If combustible dust, fume, or mist is generated, process owners/operators should at a minimum:

- Comply with all applicable codes and standards. Among other considerations, current NFPA standards require owners/operators whose processes involve potentially combustible materials to have a current Hazard Analysis, which can serve as the foundation for their process hazard mitigation strategies.
- Prevent all ignition sources from entering any dust collection equipment.
- Design, select, and implement fire and explosion mitigation, suppression, and isolation strategies that are appropriate for the risks associated with their application.
- Develop and implement maintenance work practices to maintain a safe operating environment, ensuring that combustible dust, fume, or mist does not accumulate within the plant.

Donaldson recommends process owners/operators consult with experts to insure each of these responsibilities are met.

As a manufacturer and supplier of Industrial Filtration Products, Donaldson can assist process owners/operators in the selection of filtration technologies. However, process owners/operators retain all responsibility for the suitability of fire and explosion hazard mitigation, suppression, and isolation strategies. Donaldson assumes no responsibility or liability for the suitability of any fire and/or explosion mitigation strategy, or any items incorporated into a collector as part of an owner/operators hazard mitigation strategy.

Improper operation of a dust control system may contribute to conditions in the work area or facility that could result in severe personal injury and product or property damage. Check that all collection equipment is properly selected and sized for the intended use.

DO NOT operate this equipment until you have read and understand the instruction warnings in the Installation and Operations Manual. For a replacement manual, contact Donaldson Torit.

This manual contains specific precautionary statements relative to worker safety. Read thoroughly and comply as directed. Discuss the use and application of this equipment with a Donaldson Torit representative. Instruct all personnel on safe use and maintenance procedures.

**Data Sheet**

Model Number _____	Serial Number _____
Ship Date _____	Installation Date _____
Customer Name _____	
Address _____ _____	
Filter Type _____	
Accessories _____	
Other _____	

## Contents

Description.....	1	Preliminary Start-Up Check .....	11
Purpose and Intended Use .....	1	Maintenance Information.....	12
Rating and Specification Information.....	2	Operational Checklist .....	12
Operation.....	3	Filter Removal and Installation.....	12
Inspection on Arrival.....	4	Dust Disposal .....	14
Installation Codes and Procedures .....	4	Split Taper™ Bushing Mounting Instructions .....	15
Installation.....	4	Optional Equipment.....	16
Foundations or Support Framing .....	5	Hopper Assembly .....	16
Collector Location .....	5	Magnehelic® Gauge .....	17
Site Selection .....	5	Photohelic® Gauge .....	19
Rigging Instructions.....	5	Delta P Control.....	21
Hoisting Information .....	5	Delta P Plus Control .....	22
Standard Equipment.....	6	Sprinkler.....	23
Compressed Air Installation .....	7	Troubleshooting.....	24
Electrical Wiring.....	7		
Solid-State Timer Installation.....	9		

Magnehelic® and Photohelic® are registered trademarks of Dwyer Instruments, Inc.

### DANGER

**DANGER** indicates a hazardous situation which, if not avoided, will result in death or serious injury.

### WARNING

**WARNING** indicates a hazardous situation which, if not avoided, could result in death or serious injury.

### CAUTION

**CAUTION**, used with the safety alert symbol, indicates a hazardous situation which, if not avoided, could result in minor or moderate injury.

### **NOTICE**

**NOTICE** is used to address practices not related to personal injury that may result in damage to equipment.

## Description

The Torit Trunk 2000 is used to filter weld fume, dust, and particulate from plant sources and to recirculate clean air back to the workplace. Ceiling-hung or wall-supported, the compact size, coupled with large volume air handling capabilities allow this unit to be placed in a wide variety of sites previously inaccessible to high efficiency dust collectors.

Torit Ultra-Web® FR flame retardant filter cartridges are the heart of the Torit T-2000. These elements, which are an example of Donaldson Company's state-of-the-art filtration technology, help ensure that only clean air is returned to the plant environment.

## Purpose and Intended Use



Misuse or modification may result in severe personal injury and/or property damage.

Do not misuse or modify.

The T-2000, designed for source collection of weld fume, is capable of handling 890 cfm. It provides one or two extraction arms for fume collection.

The T-2000 is designed to capture fume generated from moderate to heavy welding applications.



Combustible materials such as buffing lint, paper, wood, metal dusts, weld fume, or flammable coolants or solvents represent potential fire and/or explosion hazards. Use special care when selecting, installing, and operating all dust, fume, or mist collection equipment when such combustible materials may be present in order to protect workers and property from serious injury or damage due to a fire and/or explosion.

Consult and comply with all National and Local Codes related to fire and/or explosion properties of combustible materials when determining the location and operation of all dust, fume, or mist collection equipment.

Standard Donaldson Torit equipment is not equipped with fire extinguishing or explosion protection systems.

## Rating and Specification Information

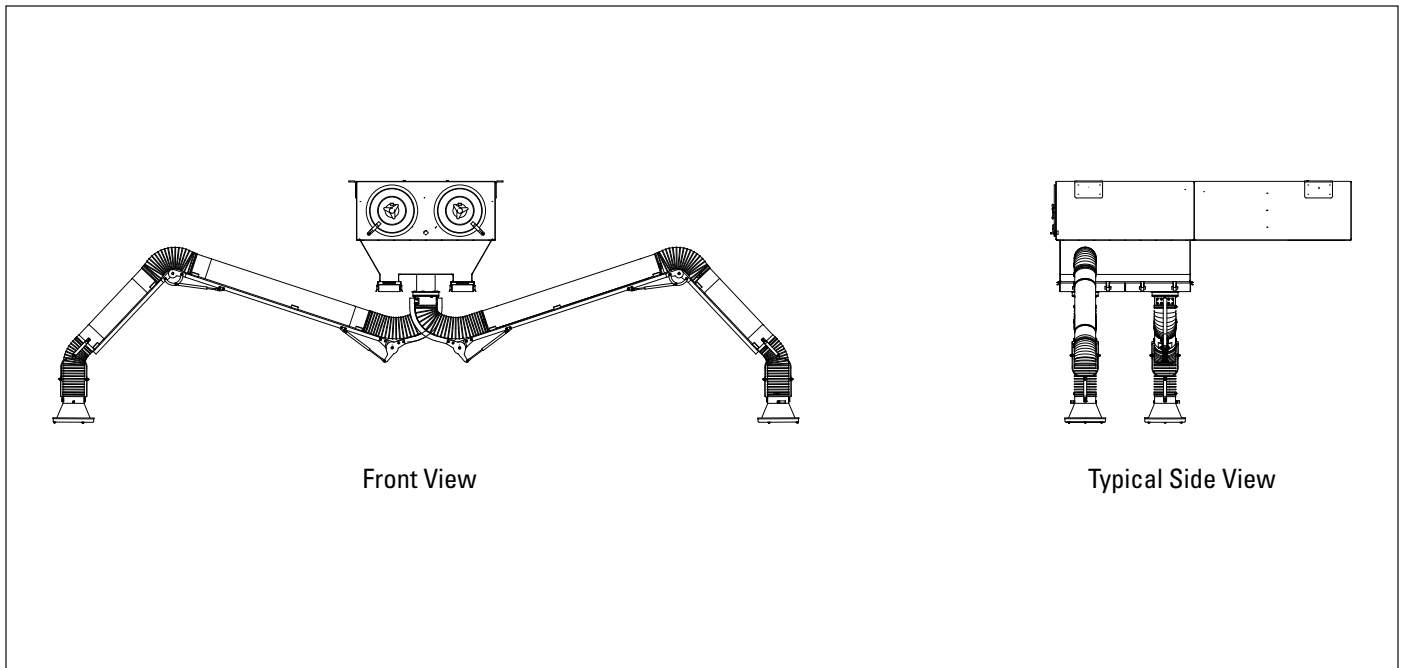

All Collectors\*:

Compressed air, maximum psig.....90 psig 1.11 scf/pulse  
Power and controls ..... 115 VAC

## Operation

Dust or fume enters through the extraction arm(s), and is collected on the outside surfaces of the filter elements. The clean, filtered air passes through the center of the filter elements, into the blower, through the silencer sections of the cabinet, and exits through the clean-air outlet.

Filter cleaning starts when the blower is turned on. A solid-state control timer energizes a solenoid valve, causing the corresponding diaphragm valve to send a pulse of compressed air through the filter elements (from the inside outward), removing the dust from the outside of the filter elements. The dust then falls into the hopper.

At the end of the pulse, the diaphragm valve closes and the elements are back in normal operation. After a preset time interval elapses, the timer sequences to the next valve in the system. This cycle will continue until the blower fan is turned OFF.

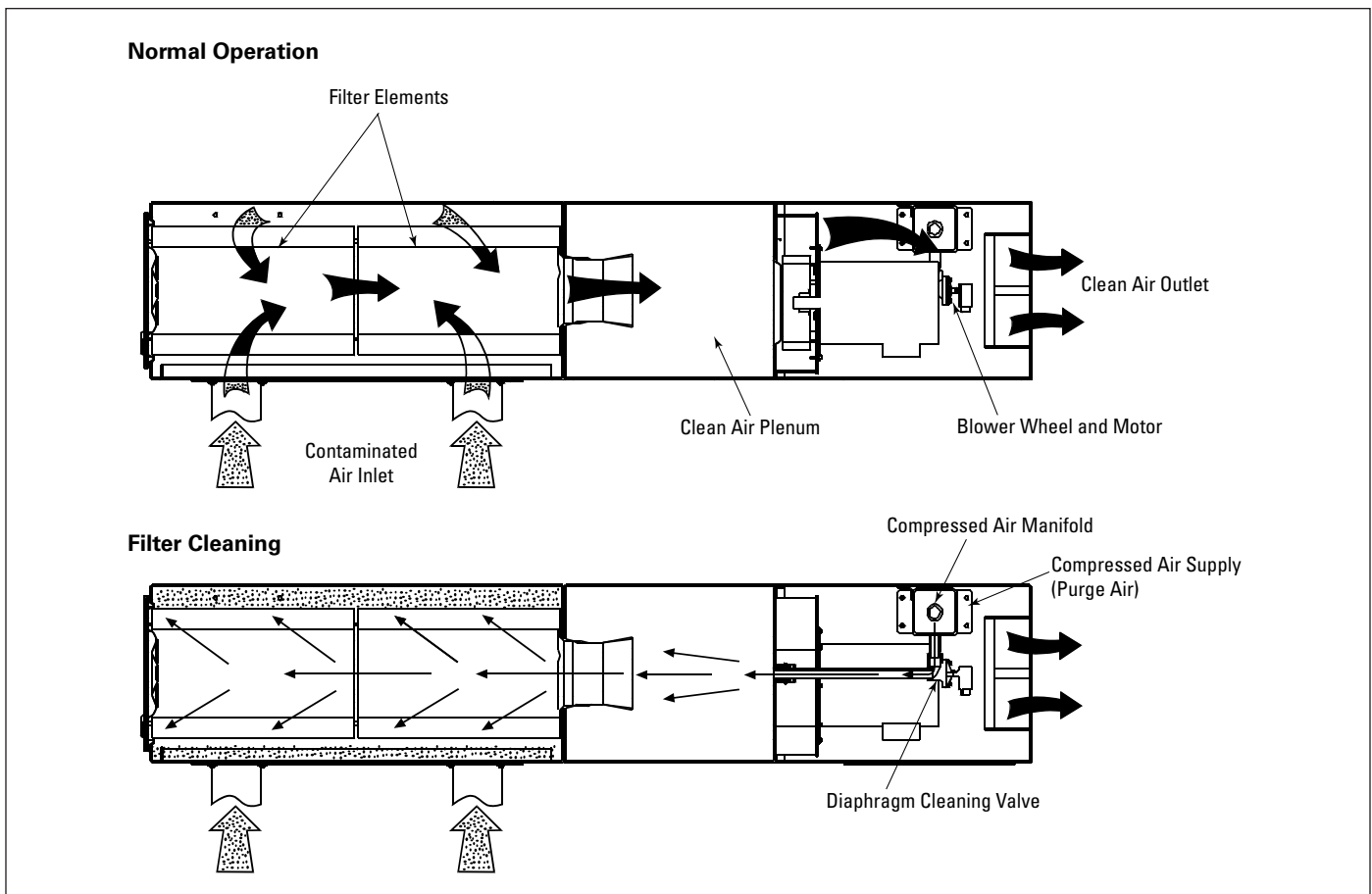

Unit Operation

## Inspection on Arrival

1. Inspect collector upon delivery.
2. Report any damage to the delivery carrier.
3. Request a written inspection report from the Claims Inspector to substantiate any damage claim.
4. File claims with the delivery carrier.
5. Compare collector received with description of product ordered.
6. Report incomplete shipments to the delivery carrier and your Donaldson Torit representative.
7. Remove crates and shipping straps. Remove loose components and accessory packages before lifting collector from truck.
8. Check for hardware that may have loosened during shipping.
9. Use caution removing temporary covers.

## Installation Codes and Procedures



Codes may regulate recirculating filtered air in your facility.

Consult with the appropriate authorities having jurisdiction to ensure compliance with all national and local codes regarding recirculating filtered air.

Safe and efficient operation of the collector depends on proper installation.

Authorities with jurisdiction should be consulted before installing to verify local codes and installation procedures. In the absence of such codes, install collector according to the National Electric Code, NFPA No. 70-latest edition and NFPA 91 (NFPA 654 if combustible dust is present).

A qualified installation and service agent must complete installation and service of this equipment.

All shipping materials, including shipping covers, must be removed from the collector prior to or during collector installation.

### NOTICE

Failure to remove shipping materials from the collector will compromise collector performance.

Inspect collector to ensure all hardware is properly installed and tight prior to operating collector.

## Installation



Use proper equipment and adopt all safety precautions needed for servicing equipment.

Electrical service or maintenance work must be performed by a qualified electrician and comply with all applicable national and local codes.

Turn power off and lock out electrical power sources before performing service or maintenance work.

Do not install in classified hazardous atmospheres without an enclosure rated for the application.

Turn compressed air supply OFF, bleed and lock out lines before performing service or maintenance work.



Site selection must account for wind, seismic zone, and other

load conditions when selecting the location for collectors.

Codes may regulate acceptable locations for installing dust collectors. Consult with the appropriate authorities having jurisdiction to ensure compliance with all national and local codes regarding dust collector installation.

Collectors must be anchored in a manner consistent with local code requirements. Anchors must be sufficient to support dead, live, seismic, and other anticipated loads.

Consult a qualified engineer for final selection of anchorage.

### NOTICE

Do not set compressed-air pressure above 100-psig as component damage can occur.

All compressed air components must be sized to meet the system requirements of 90-100-psig supply pressure.

The compressed-air supply must be oil and moisture free. Contamination in the compressed air used to clean filters will result in poor cleaning, cleaning valve failure, or poor collector performance.

Purge compressed air lines to remove debris before connecting to the collector's compressed air manifold.

The collector is suitable for indoor installations. Reference the Rating and Specification Information.

### Foundations or Support Framing

Prepare the foundation or support framing in the selected location. Foundation or support framing must comply with local code requirements and may require engineering.

Foundation and support framing must be capable of supporting dead, live, wind, seismic and other applicable loads. Consult a qualified engineer for final selection of foundation or support framing.

### Collector Location

**WARNING** Donaldson Torit equipment is not designed to support site installed ducts, interconnecting piping, or electrical services. All ducts, piping, or electrical services must be adequately supported to prevent severe personal injury and/or property damage.

When hazardous conditions or materials are present, consult with local authorities for the proper location of the collector.

**CAUTION** Dust collection equipment may reach peak sound pressure levels above 80 dB (A). Noise levels should be considered when selecting collector location.

Locate the collector to ensure easy access to electrical and compressed air connections, to simplify solids collection container handling and routine maintenance, and to ensure the straightest inlet and outlet ducts.

### Site Selection

This collector can be located on a foundation or structural framing. It can also be suspended or hung from overhead supports. The supports must be adequate to carry the live load of the collector and installed to reduce sway or vibration to the collector.

Provide clearance from heat sources and avoid any interference with utilities when selecting the location.

### Rigging Instructions

#### Suggested Tools & Equipment

Clevis Pins and Clamps	Lifting Slings
Crane or Forklift	Pipe Sealant
Drift Pins	Pipe Wrenches
Drill and Drill Bits	Screwdrivers
End Wrenches	Socket Wrenches
Adjustable Wrench	Spreader Bars
Torque Wrench (inch/lbs, 9/16-in Socket)	

### Hoisting Information

**WARNING** Failure to lift the collector correctly can result in severe personal injury and/or property damage.

Use appropriate lifting equipment and adopt all safety precautions needed for moving and handling the equipment.

A crane or forklift is recommended for unloading, assembly, and installation of the collector.

Location must be clear of all obstructions, such as utility lines or roof overhang.

Use all lifting points provided.

Use clevis connectors, not hooks, on lifting slings.

Use spreader bars to prevent damage to collector's casing.

Check the Specification Control drawing for weight and dimensions of the collector and components to ensure adequate crane capacity.

Allow only qualified crane or forklift operators to lift the equipment.

Refer to applicable OSHA regulations and local codes when using cranes, forklifts, and other lifting equipment.

Lift collector and accessories separately and assemble after collector is in place.

Use drift pins to align holes in section flanges during assembly.



## Standard Equipment

### **⚠ WARNING**

Improper mounting of an extraction arm may result in personal injury. Follow all installation directions carefully.

1. The T-2000 collector is shipped assembled from the factory, except for the trunks, which are attached after the dust collector has been placed. Typically the Trunk 2000 is suspended from the ceiling; however, it can be supported by other means, as long as they are appropriate for the alternate location. Collector Suspension shows the recommended method of suspending the Trunk 2000.
2. After the collector has been placed, level by adjusting the hangers at each corner.
3. Fasten the extraction arms shown in Extraction Arm Installation and in the Extraction Arm Installation and Operation Manual.

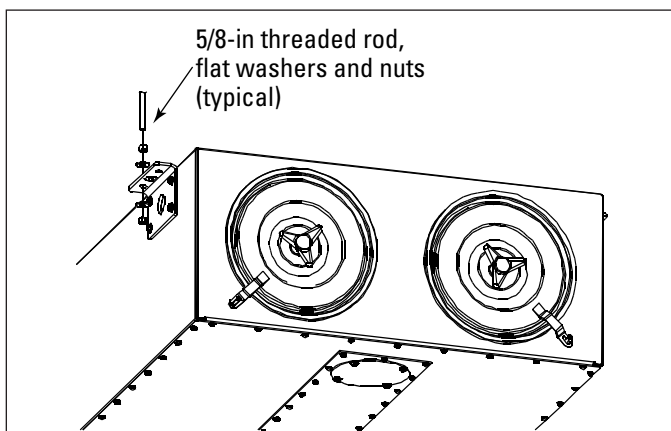

Collector Suspension

Each Trunk 2000 collector is equipped with two 115 VAC solenoid valves that control the pulse cleaning valves. The DIN connector of the solenoid valve has two power leads and a ground connection.

The 6.5-ft, 10-ft and 13-ft extraction arms have a 12V, 65-watt halogen light located in each hood.

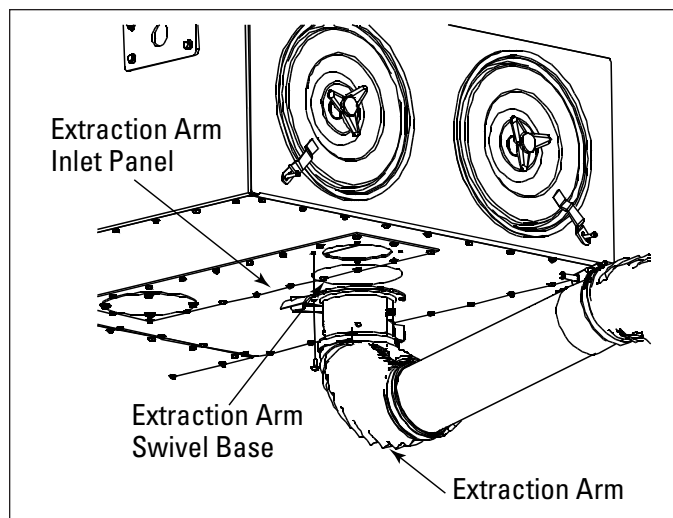

Extraction Arm Installation  
(arm may vary from drawing)

Both the 12V and 115V power to the collector are supplied from the Torit control box. The control box can be mounted where it is convenient to the user.

### **NOTICE**

When final light wiring connections are made at the collector, allow enough slack for free rotation and motion of the trunk.

The 115 VAC timer in the control box controls the solenoid valves. Total power requirement of the control box is 130 watts, including the two 65-watt halogen lights, one in each Extraction Arm hood.

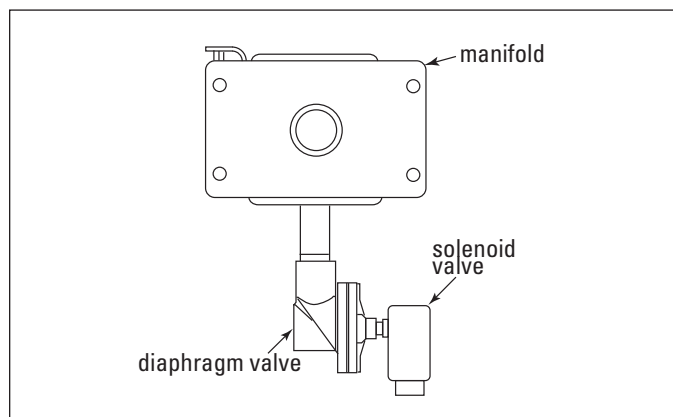

Solenoid Valve

## Compressed Air Installation

**WARNING** Turn compressed air supply OFF, bleed and lock out lines before performing service or maintenance work.

A safety exhaust valve should be used to isolate the compressed air supply. The safety exhaust valve should completely exhaust pressure in the collector manifolds when closed, should be capable of being interlocked with fire or explosion mitigation equipment and should include provisions to allow closed-position locking.

**NOTICE** Do not set compressed-air pressure above 100-psig as component damage can occur.

All compressed air components must be sized to meet the system requirements of 90-100-psig supply pressure.

The compressed-air supply must be oil and moisture free. Contamination in the compressed air used to clean filters will result in poor cleaning, cleaning valve failure, or poor collector performance.

Purge compressed-air lines to remove debris before connecting to the collector's compressed-air manifold.

1. Remove the plastic pipe plug from the collector's air manifold and connect the compressed-air supply lines. Use thread-sealing tape or pipe sealant on all compressed-air connections.
2. Install a customer-supplied shut-off valve, bleed-type regulator with gauge, filter, and automatic condensate valve in the compressed-air supply line.
3. Set compressed-air supply to 90-psig. The pulse-cleaning controls are factory set to clean one or more filters every 10-seconds during a cleaning cycle.

## Electrical Wiring

**WARNING** Electrical installation, service, or maintenance work must be performed by a qualified electrician and comply with all applicable national and local codes.

Turn power off and lock out electrical power sources before performing service or maintenance work.

Do not install in classified hazardous atmospheres without an enclosure rated for the application.

All electrical wiring and connections, including electrical grounding, should be made in accordance with the National Electric Code (NFPA No. 70-latest edition).

Check local ordinances for additional requirements that apply.

The appropriate wiring schematic and electrical rating must be used. See collector's rating plate for required voltage.

An electric disconnect switch having adequate amp capacity shall be installed in accordance with Part IX, Article 430 of the National Electrical Code (NFPA No. 70-latest edition). Check collector's rating plate for voltage and amperage ratings.

Refer to the wiring diagram for the number of wires required for main power wiring and remote wiring.



**WARNING**

Turn power off and lock out electrical power sources.

Turn compressed air supply OFF, bleed and lock out lines before performing service or maintenance work.

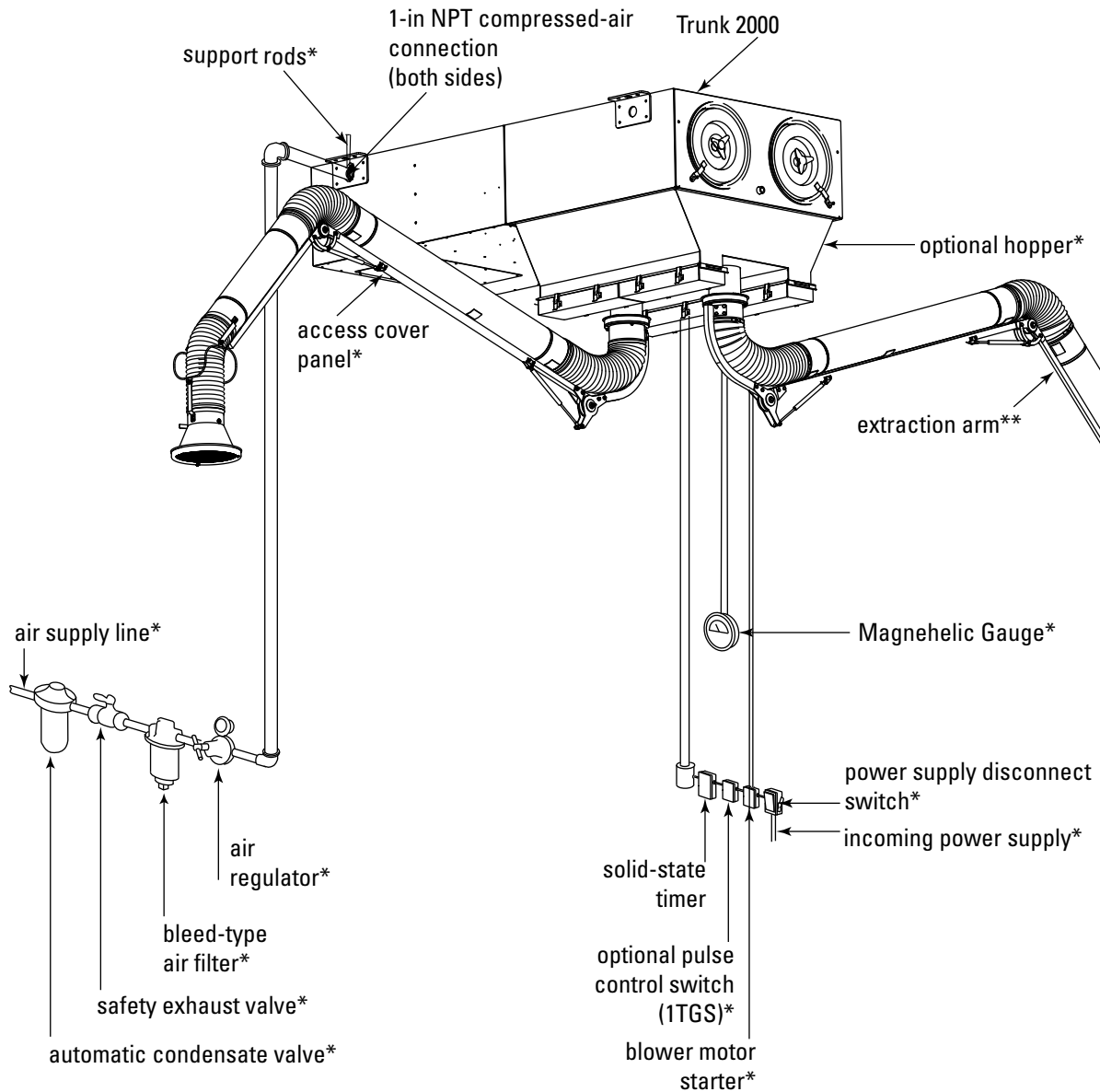

\*customer supplied

\*\*extraction arm may vary from drawing

Compressed Air Installation

## Solid-State Timer Installation

### **⚠ WARNING**

Electrical installation, service or maintenance work during installation must be performed by a qualified electrician and comply with all applicable national and local codes.

Turn power off and lock out electrical power sources before performing installation, service, or maintenance work.

Do not install in classified hazardous atmospheres without an enclosure rated for the application.

**Optional Switch 1TGS:** Closure of switch 1TGS applies power to the timer control circuit board, which is in parallel with the low voltage coil of the fan magnetic starter. Supplying power initiates the control board's preset OFF time. At the end of the OFF time, the control will energize a solenoid to provide the cleaning pulse for one segment of filter elements, and then step to the next segment. This cycle continues until the T-2000 fan starter is turned off or an auxiliary switch (not supplied) opens, unless an auxiliary control such as a Photohelic pressure switch is used to control the timer pressure switch circuit. Make sure that the programming pin on the control board is located on the correct number of solenoid valves being used. See Typical Wiring Diagram.

Mount the Trunk 2000 control box(es) and fan starter switch(es) in a safe, convenient location. Install conduit and wire up to the collector(s). The disconnect fuses, magnetic fan starter, and optional control switch 1TGS are to be supplied by others. All electrical apparatus should be properly sized for the required voltage. The fan starter should contain a low voltage control circuit.

Use the wiring diagram (and inside the control box) to connect the blower motor, motor starter, lights, solid-state control timer, solenoid valves, and the control switch (or optional Photohelic gauge if used). In grounded systems, neutral to control box must be connected to L2 of control box terminal board.

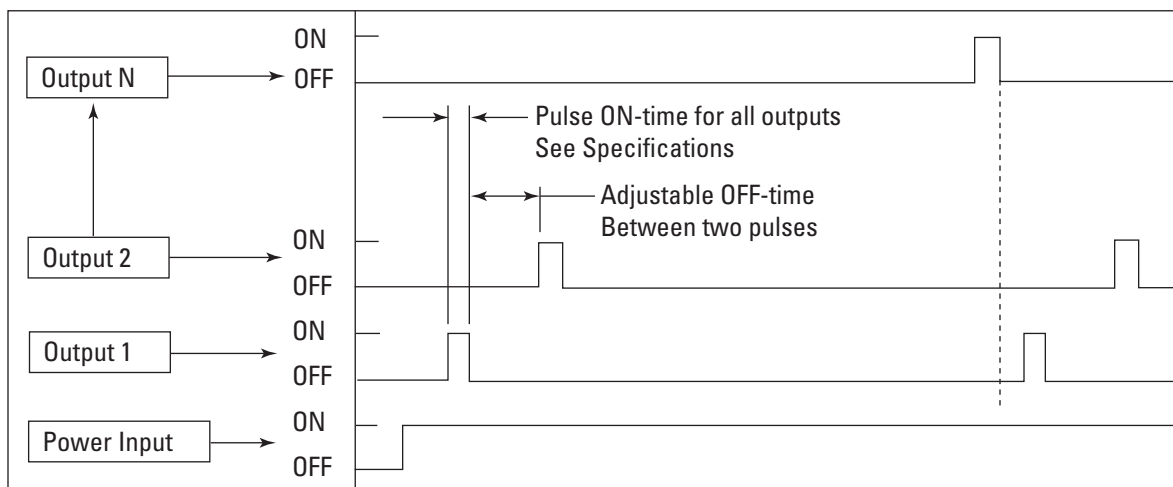

Operating Logic Diagram

**Input**  
 105-135V/50 -60Hz/1Ph (others, including 220VAC are available)

**Output Solenoids**  
 The load is carried and turned ON and OFF by the 200 watt maximum-load-per-output solid-state switch.

**Pulse ON Time**  
 Factory set at 100-milliseconds.

**NOTICE** Do not adjust pulse ON time unless the proper test equipment is available. Too much or too little ON time can cause shortened filter life.

**Pulse OFF Time**  
 Factory set at 10-seconds, adjustable from 1 to 1.5-second minimum to maximum 60 to 66-second.

**Operating Temperature Range**  
 -20° F to 130° F

**Transient Voltage Protection**  
 50 kW transient volts for 20-millisecond duration once every 20 seconds, 1% duty cycle.

**Solenoid Valves**  
 115-V at 19.7 watts each

**Compressed-Air**  
 Set compressed-air supply at 90-psig.

**NOTICE** Do not increase supply pressure above 100-psig as component damage can occur.

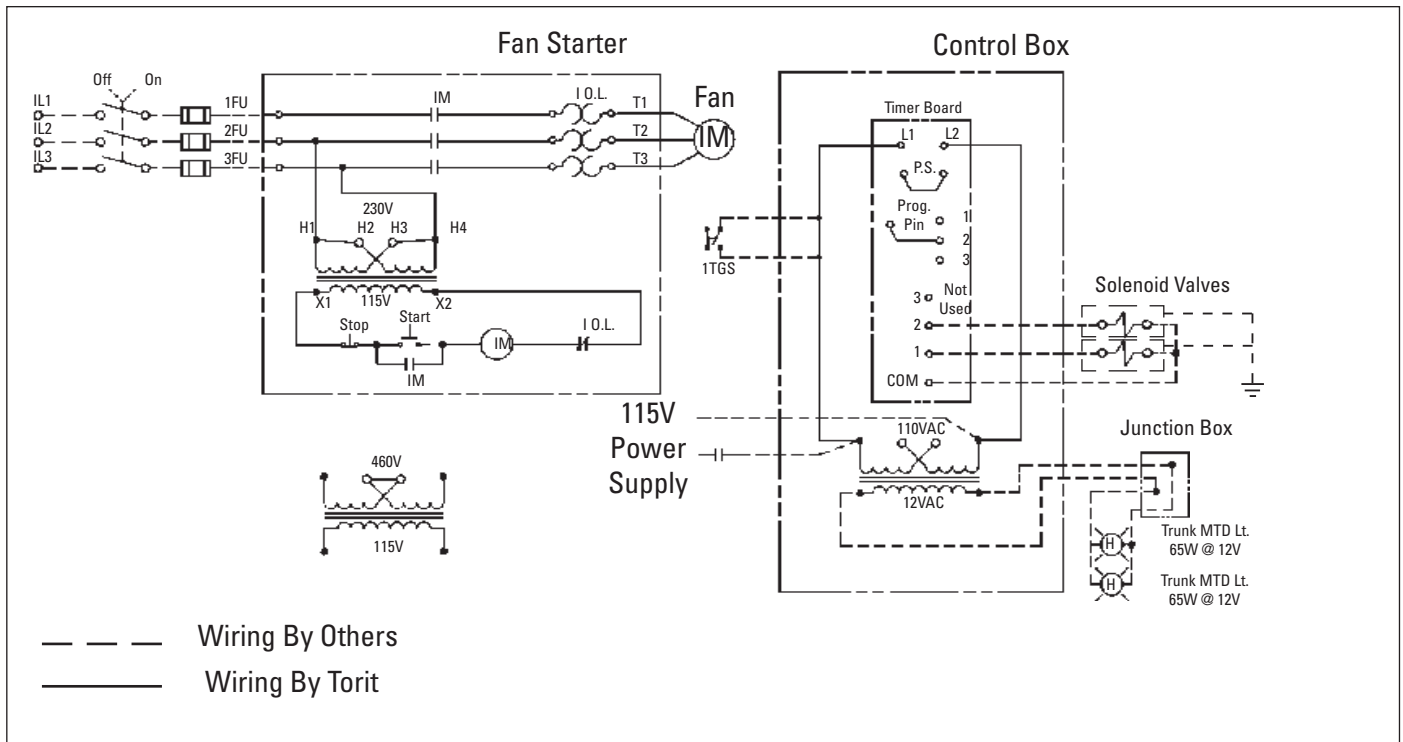

Solid-State Timer Typical Wiring Diagram

## Preliminary Start-Up Check

Instruct all personnel on safe use and maintenance procedures.

### **WARNING**

Electrical work during installation, service or maintenance must be performed by a qualified electrician and comply with all applicable national and local codes.

Turn power off and lock out electrical power sources before performing service or maintenance work.

Turn compressed air supply OFF, bleed and lock out lines before performing service or maintenance work.

Check that the collector is clear and free of all debris before starting.

Do not install in classified hazardous atmospheres without an enclosure rated for the application.

Optional fans over 600 lbs must be independently supported.

1. Check all electrical connections for tightness and contact.
2. Check for proper rotation as noted on the fan and/or hopper discharge device housing.

To reverse rotation, single-phase power supply:  
Follow manufacturer's instructions on the motor's nameplate.

To reverse rotation, three-phase power supply:  
Switch any two leads on the motor junction box.

### **WARNING**

Do not interchange a power lead with the ground wire. Severe personal injury and/or property damage may result.

3. All access panels should be sealed and secure.

6. Check and remove all loose items in or near the inlet and outlet of the collector.
7. Check that all remote controls and solenoid enclosures (if applicable) are properly wired and all service switches are in the OFF position.
8. Check that all optional accessories are installed properly and secured.
9. Turn power ON at source.
10. Turn the compressed-air supply ON. Adjust pressure regulator for 90-100 psig.
11. Turn fan motor ON.

### **WARNING**

Do not look into fan outlet to determine rotation. View the fan rotation through the back of the motor.

Check that the exhaust plenum is free of tools or debris before checking blower/fan rotation.

Stand clear of exhaust to avoid personal injury.

12. Check the operation of the solenoid valves by turning the pulse control switch ON. The solenoid valves should open and close continuously at preset ON and OFF times.

## Maintenance Information

Instruct all personnel on safe use and maintenance procedures.

### **WARNING**

Use proper equipment and adopt all safety precautions needed for servicing equipment.

Use appropriate access equipment. The standard collector is not equipped with access platforms unless noted on specification drawings.

Electrical service or maintenance work must be performed by a qualified electrician and comply with all applicable national and local codes.

Turn power off and lock out electrical power sources before performing service or maintenance work.

Do not install in classified hazardous atmospheres without an enclosure rated for the application.

Turn compressed air supply OFF, bleed and lock out lines before performing service or maintenance work.

### **NOTICE**

Do not set compressed-air pressure above 100-psig as component damage can occur.

All compressed air components must be sized to meet the system requirements of 90-100 psig supply pressure.

The compressed-air supply must be oil and moisture free. Contamination in the compressed air used to clean filters will result in poor cleaning, cleaning valve failure, or poor collector performance.

Purge compressed air lines to remove debris before connecting to the collector's compressed air manifold.

## Operational Checklist

1. Monitor the physical condition of the collector and repair or replace any damaged components.

Routine inspections will minimize downtime and maintain optimum system performance. This is particularly important on continuous-duty applications.

2. Periodically check the compressed air components and replace compressed air filters.

Drain moisture following the manufacturer's instructions. With the compressed air supply ON, check the cleaning valves, solenoid valves, and tubing for leaks. Replace as necessary.

3. Monitor pressure drop across filters.

Abnormal changes in pressure drop may indicate a change in operating conditions and possibly a fault to be corrected. For example, prolonged lack of compressed air will cause an excess build-up of dust on the filters resulting in increased pressure drop. Cleaning off-line with no flow usually restores the filters to normal pressure drop.

4. Monitor exhaust.

5. Monitor dust disposal.

## Filter Removal and Installation

### **WARNING**

Use proper safety and protective equipment when removing contaminants and filters.

Dirty filters may be heavier than they appear.

Use care when removing filters to avoid personal injury and/or property damage.

Turn power off and lock out electrical power sources before performing service or maintenance work.

Turn compressed air supply OFF, bleed and lock out lines before performing service or maintenance work.

### **CAUTION**

Do not operate with missing or damaged filters.

## Filter Removal

1. Turn power to collector OFF.
2. Remove the filter access covers by turning the knob counterclockwise.
3. Break the seal between the filter cartridge and the sealing surface.
4. Slowly rotate the cartridge 1/2-turn to remove dust that may have accumulated on the top of the filter.
5. Slide the filter out the access port along the suspension yoke and dispose of properly.
6. Inspect and clean the sealing surface if necessary.

### **NOTICE**

Clean dust from gasket sealing area to ensure a positive filter

gasket seal.

7. Check for an accumulation of dust in the storage area and empty as necessary.

## Filter Installation

1. Slide the new filter cartridge onto each suspension yoke.

### **NOTICE**

Insert the filter, gasket end first.

2. Wipe cover gaskets clean and replace covers. Tighten securely by hand.

### **NOTICE**

Inspect and replace any covers with damaged or missing gaskets. Failure to do so may result in leakage in the collector.

Tighten access covers securely by hand. Gaskets must be compressed to seal properly.

3. Turn electrical power and compressed air supply ON before starting unit.

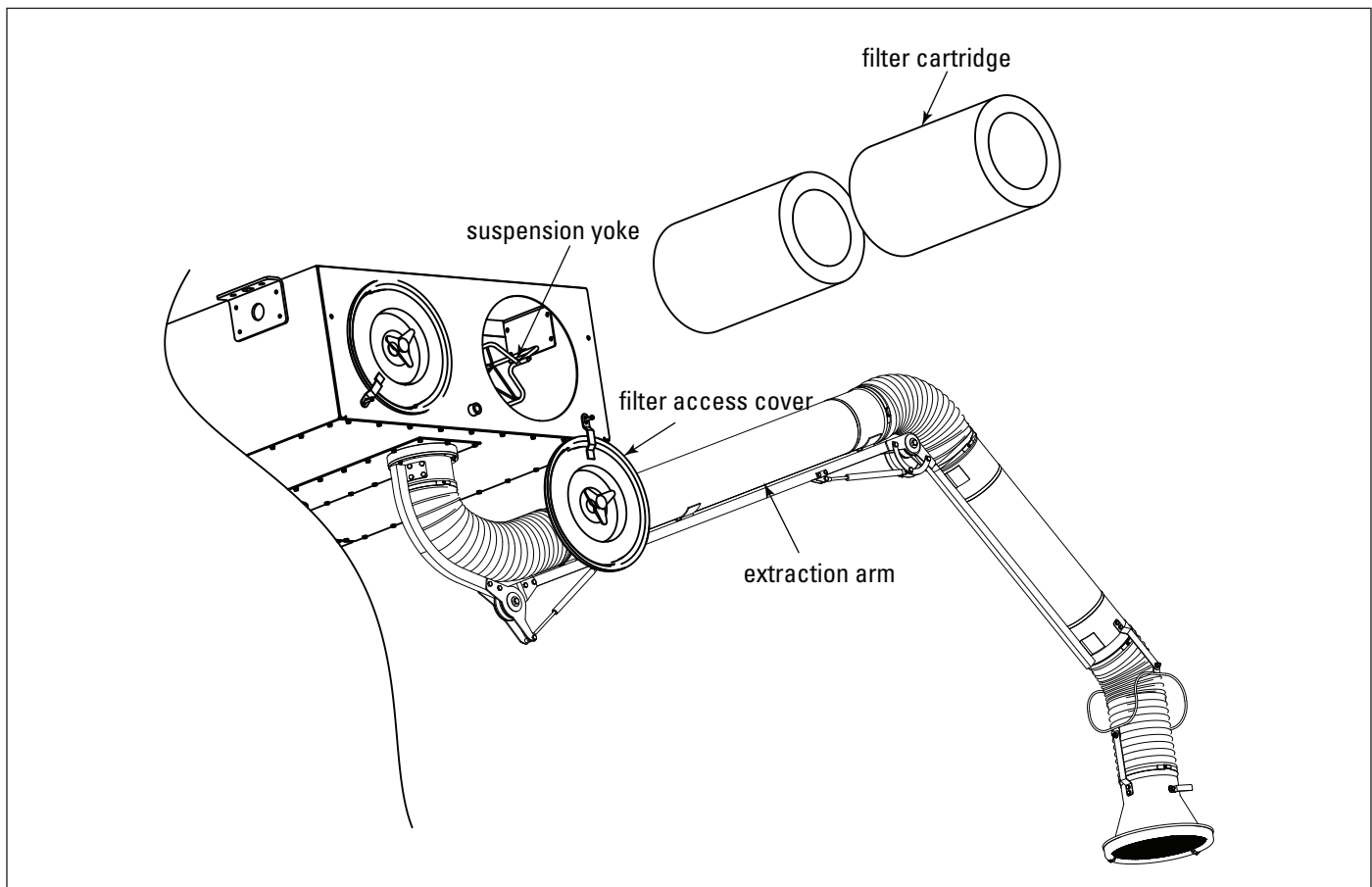

Filter Removal and Replacement (arm may vary from drawing)



## Dust Disposal

### Standard Bottom Unit

1. Open the filter-access covers and remove the filter cartridges. See Filter Removal and Installation.
2. Remove the dust with a dry sweeper or brush and dispose of properly.
3. Replace filters and close filter-access covers securely. See Filter Removal and Installation.
4. Turn electrical power and compressed air supply ON before starting unit.

### Hopper Bottom Unit

1. Open the filter-access covers and remove the filter cartridges. See Filter Removal and Installation.
2. Sweep or brush hopper walls.
3. Replace filters and close filter-access covers securely. See Filter Removal and Installation.
4. Remove the dustpans and dispose of dust properly. Empty and clean the dust pans every other day in heavy dust-load applications, and every week in light-to-medium applications.

**NOTICE**

Full dust pans can weigh up to 45-lbs. Use care when removing.

5. Inspect the gasket for wear that could cause a leak during operation. Replace if necessary.
6. Clean the baffle with a dry brush or dry putty knife.
7. Inspect the draw latches for breaks, deformities, or wear and replace as necessary.
8. Reinstall the dust pans.
9. Turn electrical power and compressed air supply ON before starting unit.

## Split Taper™ Bushing Mounting Instructions

Many fans are furnished with split taper bushings for mounting the impeller to the shaft. When properly assembled, the bushings grip the hub with a positive clamping action.

1. Bushel barrel and bore of impeller are tapered to ensure concentric mounting and a true running propeller.
2. Capscrews, when tightened, lock bushing in propeller. Use special plated capscrews and nylock nuts.

Bushing No.	Bolt Size	Torque Ft-Lbs
QT/QH/L/H	1/4-20	7-1/2

3. Bushing is split so that when the locking capscrews force bushing into tapered bore, the bushing grips the shaft with a positive clamping fit. This will withstand vibration and heavy loads without being loosened.
4. Impeller and bushing assembly is keyed to the shaft and held in place by compression, which adds driving strength.

Note: Before assembly, ensure shaft and keyway are clean and smooth. Check key size with both shaft and bushing keyway.

5. To assemble, insert the capscrews through the clearance holes in the bushing and install bushing loosely into the impeller. Do not press or drive. Start capscrews by hand, turning them just enough to engage threads in the nylock nut. Do not use a wrench at this time. The bushing should be loose enough in the propeller to move freely. Slide impeller and bushing assembly onto shaft, allowing adequate clearance for shaft end play to prevent friction. Fit key into keyway. Do not force impeller and bushing onto shaft. If it does not go on easily, check shaft, bushing, and key sizes once again.

### CAUTION

Do not attempt to pull bushing flange flush with hub end. There should be a clearance which varies approximately 3/16-in to 1/4-in with the busing size when tightened. This is not a locating dimension.

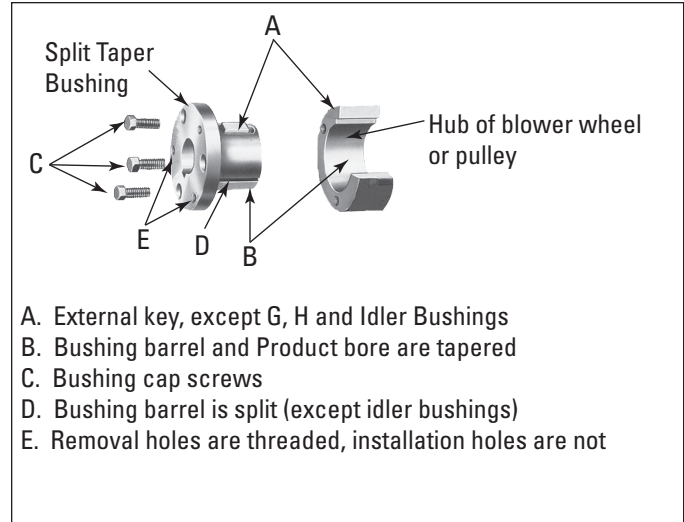

Split Taper Bushing Installation

Tighten capscrews gradually and evenly with wrench similar to mounting an automobile wheel. Rotate a quarter turn on each capscrew successively until all capscrews are tight. These capscrews force the taper bushing into the hub, which in turn compresses the bushing onto the shaft. This makes a positive clamping fit. The torque must not exceed the value specified in the table.

### Impeller Assembly Removal

1. Remove all capscrews from impeller and hub assembly.
2. Insert capscrews into the threaded holes in the bushing flange.
3. Tighten each bolt in quarter of a turn increments to push the impeller off the bushing. This forces the bushing loose from the propeller hub and releases the compression so that the entire assembly will slide from the shaft.
4. Pull the bushing off the shaft.

Note: If the assembly has been in place sometime it may be necessary to use a wheel puller to remove the bushing. Never use a wheel puller on the impeller.

Browning® is a registered trademark and Split Taper™ is a tradename of Emerson Power Transmission Manufacturing, L.P.

## Optional Equipment

### Hopper Assembly

#### **WARNING**

Failure to lift the collector correctly can result in severe personal injury and/or property damage.

Use appropriate lifting equipment and adopt all safety precautions needed for moving and handling the equipment.

A crane or forklift is recommended for unloading, assembly, and installation of the collector.

Location must be clear of all obstructions, such as utility lines or roof overhang.

2. Remove the protective shipping cover from the bottom of the T-2000 dirty-air plenum.
3. Remove the hopper from packaging.
4. Apply 1/4-in diameter, rope-type sealant to the hopper flange.
5. Using appropriate lifting equipment, lift the hopper into position under the unit and secure with thirty-six 1/4-20 UNC x 3/4-in thread-forming screws supplied. Remove the two round covers to install the extraction arms to the unit. See Extraction Arm Installation and Operation Manual for instructions.

#### **NOTICE**

Do not over tighten thread-forming screws.

4. Remove lifting equipment.

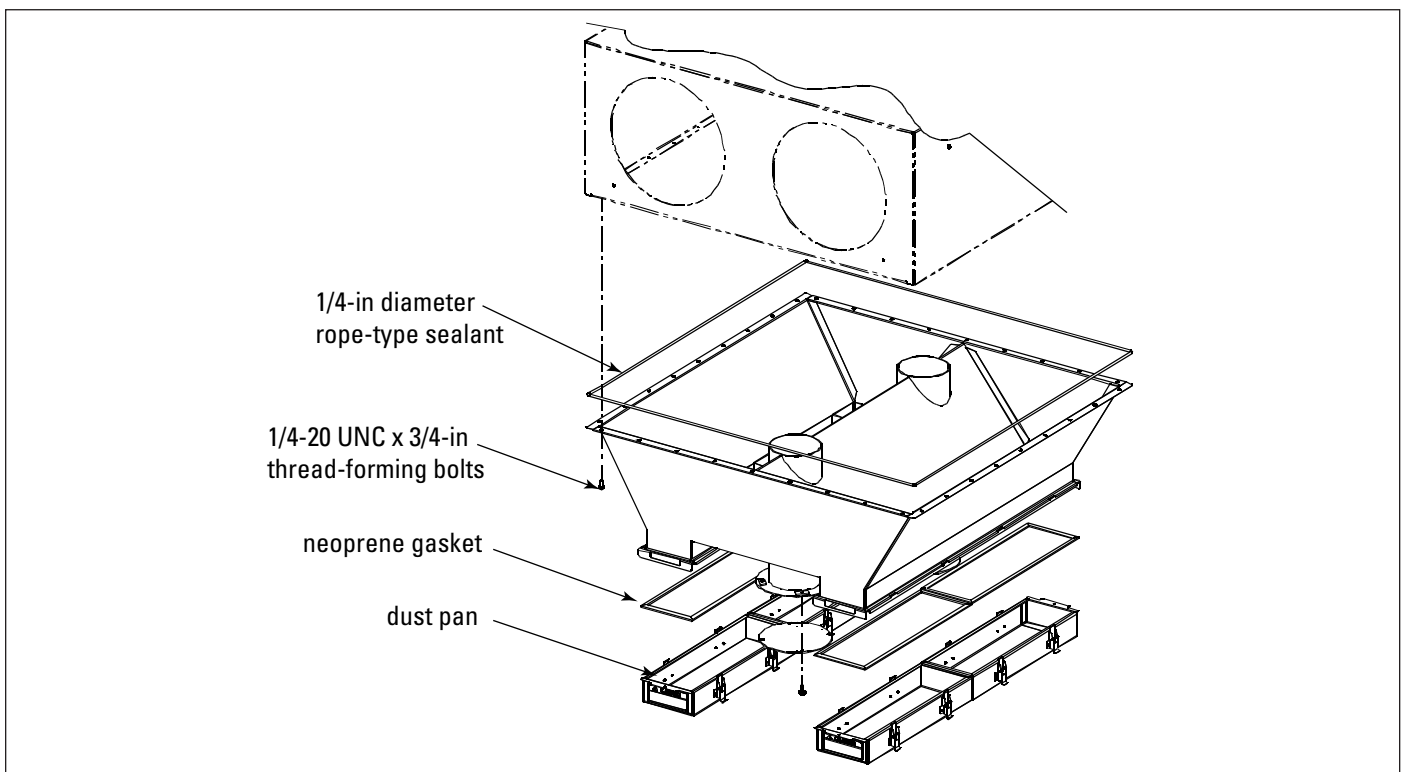

Hopper Assembly

## Magnehelic® Gauge

The Magnehelic is a differential pressure gauge used to measure the pressure difference between the clean-air and dirty-air plenums and provides a visual display of filter change requirements. The high-pressure tap is located in the dirty-air plenum and the low-pressure tap is located in the clean-air plenum.

1. Choose a convenient, accessible location on or near the collector for mounting that provides the best visual advantage.
2. Plug the pressure ports on the back of the gauge using two, 1/8-in NPT pipe plugs supplied. Install two, 1/8-in NPT male adapters supplied with the gauge into the high- and low-pressure ports on the side of the gauges.
3. Attach the mounting bracket using three, #6-32 x 1/4-in screws supplied.
4. Mount the gauge and bracket assembly to the supporting structure using two, self-drilling screws.
5. Thirty-five feet of plastic tubing is supplied and must be cut in two sections. Connect one section of tubing from the gauge's high-pressure port to the pressure fitting located in the dirty-air plenum. Connect remaining tubing from the gauge's low-pressure port to the fitting in the clean-air plenum. Additional tubing can be ordered from your representative.
6. Zero and maintain the gauge as directed in the manufacturer's Operating and Maintenance Instructions provided.

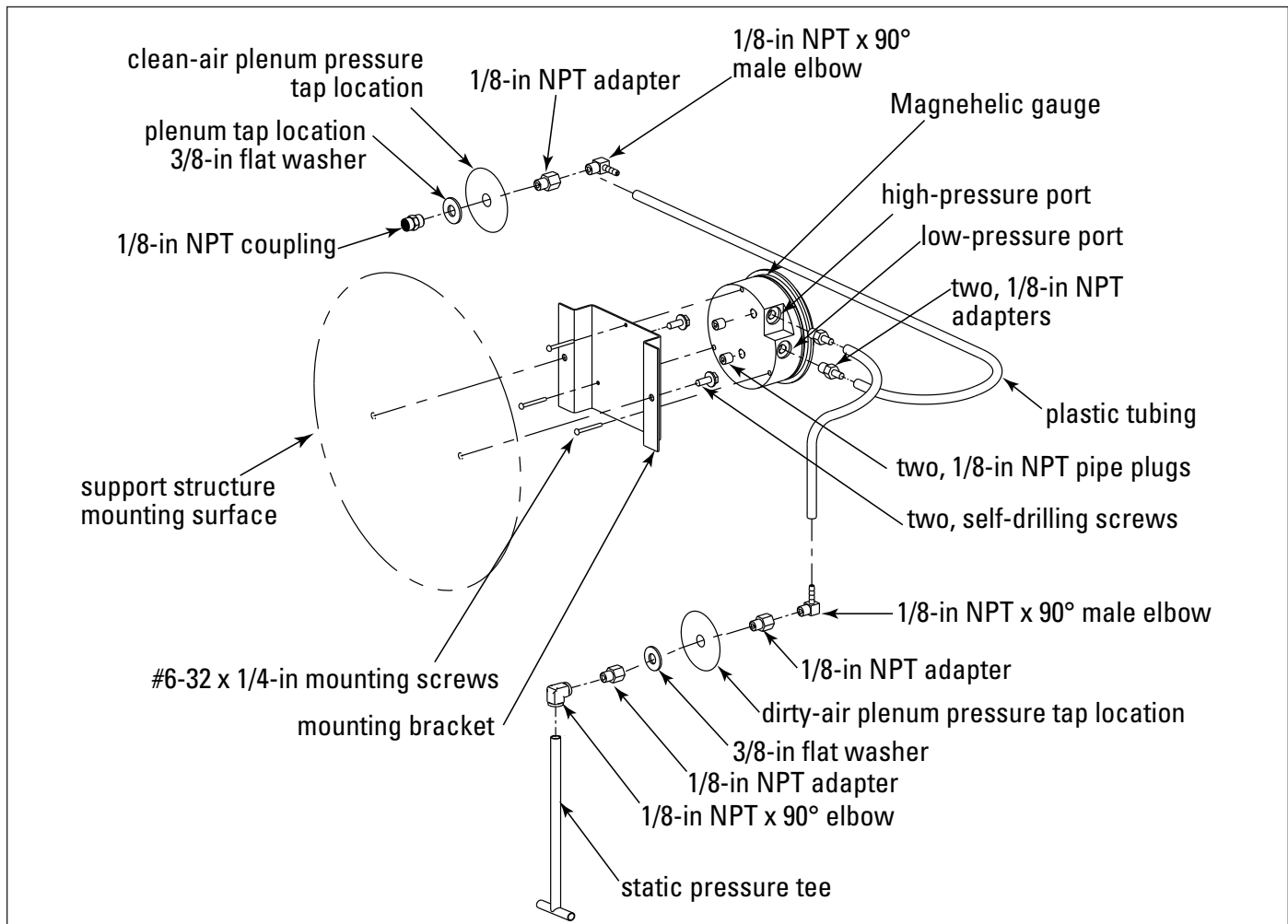

Magnehelic Gauge Assembly

**This Page Intentionally Left Blank**

## Photohelic® Gauge

### **WARNING**

Electrical installation, service, or maintenance work must

be performed by a qualified electrician and comply with all applicable national and local codes.

Turn power off and lock out electrical power sources before performing service or maintenance work.

Do not install in classified hazardous atmospheres without an enclosure rated for the application.

The Photohelic combines the functions of a differential pressure gauge and a pressure-based switch. The gauge function measures the pressure difference between the clean-air and dirty-air plenums and provides a visual display of filter condition. The high-pressure tap is located in the dirty-air plenum and a low-pressure tap is located in the clean-air plenum. The pressure-based switch function provides high-pressure ON and low-pressure OFF control of the filter cleaning system.

1. Choose a convenient, accessible location on or near the collector for mounting that provides the best visual advantage.
2. Mount the gauge to the remote panel or door using the mounting ring, retaining ring, and four #6-32 x 1 1/4-in screws. Do not tighten screws. Connect two, 1/8-in NPT x 1/4-in OD male adapters to the gauge's high- and low-pressure ports. Tighten screws.
3. On the back of the gauge, remove four #6-32 x 5/16-in screws and plastic enclosure. Set aside. Add two jumper wires supplied by customer. Remove the jumper from the pressure switch located on the timer board, if equipped. Using the 3/4-in conduit opening, wire the gauge as shown. Reassemble and fasten enclosure securely.
4. Thirty-five feet of plastic tubing is supplied and must be cut in two sections. Connect one section of tubing from the gauge's high-pressure port to the pressure fitting located in the dirty-air plenum. Connect remaining tubing from the gauge's low-pressure port to the fitting in the clean-air plenum. Additional tubing can be ordered from your representative.
5. Zero and maintain the gauge as directed in the manufacturer's Operating and Maintenance Instructions provided.

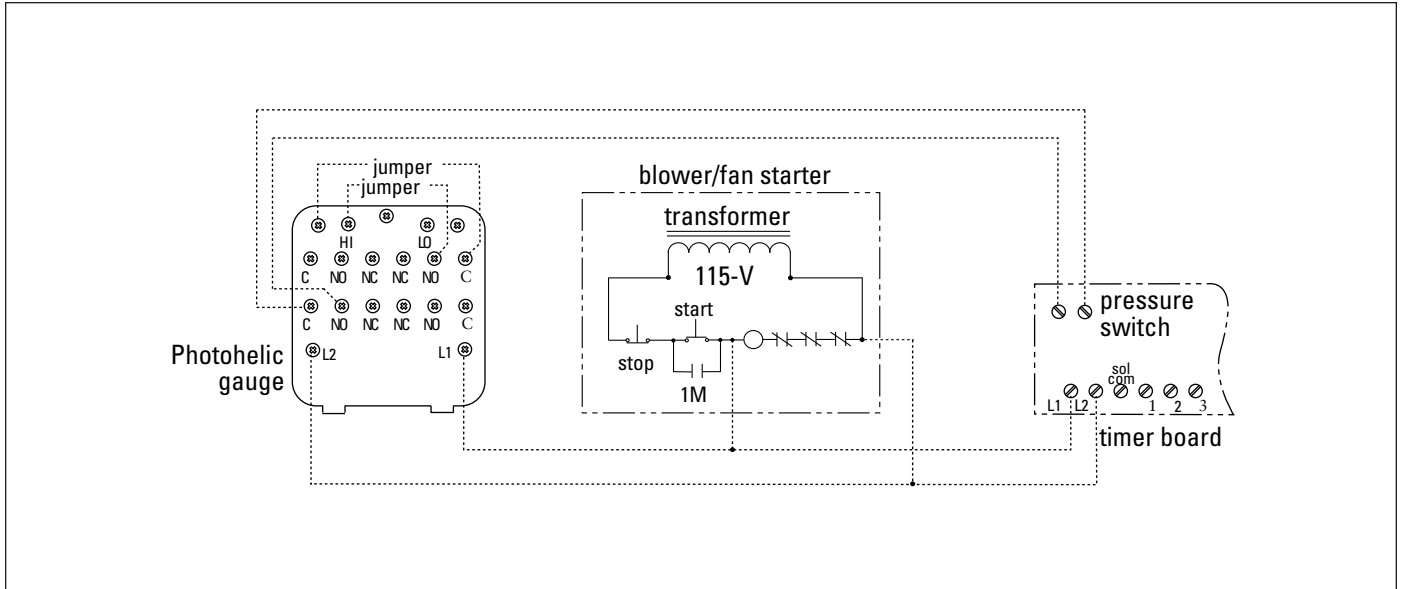

Photohelic Gauge Wiring

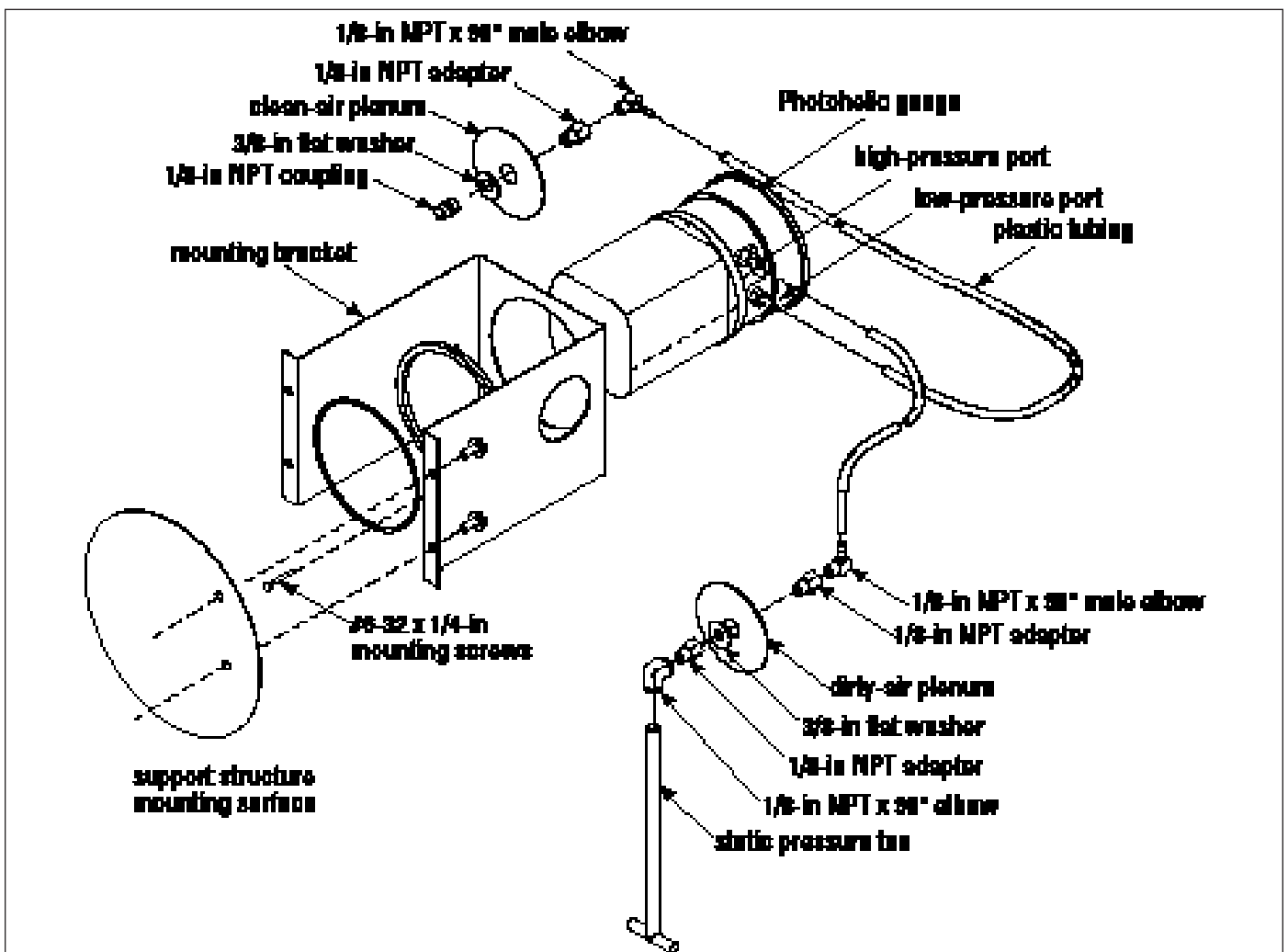

Photohelic Gauge Installation

## Delta P Control

For complete information, see the most current version of the Delta P Installation, Operation, and Maintenance manual.

### Description

The Delta P Controller monitors the differential pressure between the clean-air and dirty-air plenums, providing a visual display of the filter condition. When combined with a pulse timer, it manages the pressure drop by turning the cleaning mechanism On and Off at the chosen limits. There are three (3) set points: High Pressure On, Low Pressure Off, and Alarm. The first two, High Pressure On and Low Pressure Off, control the filter cleaning system. The third, Alarm, provides a relay output to activate an external alarm supplied by others.

### Operation

#### Normal

The Delta P Controller monitors the pressure in the clean-air and dirty-air air plenums while the collector is running. The blower draws air through the filters, creating a pressure drop. The Delta P Controller measures the pressure drop and provides a visual display in inches water gauge or metric (SI) collectors of daPa.

#### Filter Cleaning

When the pressure drop across the filters reaches the High Pressure On setpoint, the controller closes an output relay allowing a timer to trigger the cleaning valves sequentially. When the controller senses that the pressure drop has decreased to the Low Pressure Off setpoint, the relay opens and the cleaning cycle stops. This sequence continues as long as the collector is in use, maintaining the pressure drop within a narrow range.

#### Alarm

The Alarm setpoint is set to a higher setting than the High Pressure On setpoint used to start the filter cleaning cycle. It indicates situations when the cleaning system cannot reduce the pressure drop due to cleaning system failure, lack of compressed air, or the end of the filter's useful life. There is a time delay prior to setting the Alarm to prevent nuisance trips. The Delta P Controller also provides an input connection for a remote alarm reset.



Delta P Control Display



## Delta P Plus Control

For complete information, see the most current version of the Delta P Plus Installation, Operation, and Maintenance manual.

### Description

The Delta P Plus Controller monitors the differential pressure between the clean-air and dirty-air plenums, providing a visual display of the filter condition. When combined with a pulse timer, it manages the pressure drop by turning the cleaning mechanism On and Off at the chosen limits. There are three (3) set points: High Pressure On, Low Pressure Off, and Alarm. The first two, High Pressure On and Low Pressure Off, control the filter cleaning system. The third, Alarm, provides a relay output to activate an external alarm supplied by others.

The user can program the Delta P Plus Controller to pulse while the collector is running, to maintain a relatively constant pressure drop across the filters, pulse only after the collector is shut down (after-shift cleaning), or a combination of both, cleaning while running as well as end of the shift.

### Operation

#### Normal

The Delta P Plus Controller monitors the pressure on both sides of the tubesheet while the collector is running. As air flows through the filters, the resistance of the media and collected dust creates a pressure difference or "drop" between the dirty and clean air plenums. The Delta P Plus Controller measures the pressure drop and provides a visual display in inches water gauge or metric (SI) collectors of daPa.

#### Filter Cleaning

The Delta P Plus Controller offers three filter cleaning options.

1. **Differential Pressure Cleaning (DFF)** - When the pressure drop across the filters reaches the Controller's High Pressure On setpoint, the Controller closes an output relay allowing a sequential timer to trigger the cleaning valves. When the Controller senses that the pressure drop has decreased to the Low Pressure Off setpoint, the relay opens and the cleaning cycle stops. This sequence continues as long as the collector is in use, maintaining the pressure drop within a narrow range.

2. **Downtime Cleaning (DTC)** - The Delta P Plus Controller monitors the collection system. When the pressure drop exceeds the Low Pressure Off set point and then approaches zero again, the Delta P Plus Controller runs a delay timer to allow the blower to come to a stop and then engages the cleaning mechanism for a preselected time.
3. **Combined Differential and Downtime Cleaning (ALL)** - The Delta P Plus Controller combines the two functions described above; maintaining the pressure drop in a narrow band and downtime cleaning the filters when the collector is shut down. The downtime cleaning function can be toggled On or Off from the keyboard.

#### Alarm

The Alarm setpoint is set to a higher setting than the High Pressure On used to start the filter cleaning cycle. It indicates situations when the cleaning system cannot reduce the pressure drop due to cleaning system failure, lack of compressed air, or the end of the filter's useful life. There is a time delay prior to setting the Alarm to prevent nuisance trips. The Delta P Plus Controller also provides an input connection for a remote Alarm reset.



Delta P Plus Control Display

## Sprinkler

 **CAUTION**

Sprinklers can place a large quantity of water in the dust collector when activated. Provide adequate drainage to remove water. Excess water weight can cause the leg structure to collapse.

**NOTICE**

Consult with local authorities when installing fire control systems on dust collection equipment.

## Troubleshooting

Problem	Probable Cause	Remedy
<b>Fan blower and motor do not start</b>	Improper motor wire size	Rewire using the correct wire gauge as specified by national and local codes.
	Not wired correctly	Check and correct motor wiring for supply voltage. See motor manufacturer's wiring diagram. Follow wiring diagram and the National Electric Code.
	Collector not wired for available voltage	Correct wiring for proper supply voltage.
	Input circuit down	Check power supply to motor circuit on all leads.
	Electrical supply circuit down	Check power supply circuit for proper voltage. Check for fuse or circuit breaker fault. Replace as necessary.
<b>Fan blower and motor start, but do not stay running</b>	Incorrect motor starter installed	Check for proper motor starter and replace if necessary.
	Access doors are open or not closed tight	Close and tighten access doors. See Filter Installation.
	Electrical circuit overload	Check that the power supply circuit has sufficient power to run all equipment.
	Extraction Arms are not installed on T-2000	Install the extraction arm to the T-2000 inlet panel. See Extraction Arm Installation and Operation Manual.
<b>Clean-air outlet discharging dust</b>	Filters not installed correctly	See Filter Installation.
	Filter damage, dents in the end caps, gasket damage, or holes in media	Replace filters as necessary. Use only genuine Donaldson replacement parts. See Filter Installation.
	Access cover(s) loose	Tighten access cover securely. See Filter Installation.
<b>Insufficient airflow</b>	Fan rotation backwards	Proper fan rotation is clockwise from the top of the collector. The fan can be viewed through the back of the motor. See Preliminary Start-Up Check.
	Access doors open or not closed tight	Check that all access doors are in place and secured. Check that the hopper discharge opening is sealed and that dust container is installed correctly.
	Fan exhaust area restricted	Check fan exhaust area for obstructions. Remove material or debris. Adjust damper flow control.
	Filters need replacement	Remove and replace using genuine Donaldson replacement filters. See Filter Removal and Installation.
	Lack of compressed air	See Rating and Specification Information for compressed air supply requirements.

## Troubleshooting

Problem	Probable Cause	Remedy
<b>Insufficient airflow continued</b>	Pulse cleaning not energized	Use a voltmeter to check the solenoid valves in the control panel. Check pneumatic lines for kinks or obstructions.
	Dust storage area overfilled or plugged	Clean out dust storage area. See Dust Disposal.
	Pulse valves leaking compressed air	Lock out all electrical power to the collector and bleed the compressed air supply. Check for debris, valve wear, pneumatic tubing fault, or diaphragm failure by removing the diaphragm cover on the pulse valves. Check for solenoid leaks or damage. If pulse valves or solenoid valves and tubing are damaged, replace.
	Solid-State timer failure	Using a voltmeter, check supply voltage to the timer board. Check and replace the fuse on the timer board if necessary. If the fuse is good and input power is present but output voltage to the solenoid is not, replace the timer board. See Solid-State Timer Installation.
	Solid-State timer out of adjustment	See Solid-State Timer and Solid-State Timer Wiring Diagram.
	Damper control in extraction arm is closed	Check that the damper control(s) are open. The damper handle should be located in line with the rigid tubing and is the wide open position.
	Debris is blocking airflow in the extraction arm	Remove the flexible tubing on joint(s) and inspect the tubing passages for debris. Remove debris and reinstall flexible tubing for extraction arm. See Extraction Arm Installation and Operation Manual.
Extraction arm rigid ducting and/or flexible joint tubing is damaged	Check and replace any tubing that is collapsed or damaged.	
<b>Extraction arm will not remain in desired set position or is difficult to move</b>	Friction joints too loose or too tight	See the Extraction Arm Installation and Operation manual.
<b>Extraction arm light does not light</b>	Light bulb has burned out or loose wire connections	See Extraction Arm Installation and Operation manual.
<b>Extraction arm is difficult to rotate from side to side or binding, causing joint failure</b>	Swivel collar mount lacks lubrication or is binding because of particulate in moving parts	See Extraction Arm Installation and Operation manual.

<b>Problem</b>	<b>Probable Cause</b>	<b>Remedy</b>
<b>No display on the Delta P Controller</b>	No power to the controller	Use a voltmeter to check for supply voltage.
	Fuse blown	Check the fuse in the control panel. See wiring diagram inside the control panel. Replace if necessary.
<b>Display on Delta P Controller does not read zero when at rest</b>	Out of calibration	Recalibrate as described in Delta P Maintenance Manual.
	With collector discharging outside, differential pressure is present from indoor to outdoor	Recalibrate with the pressure tubing attached as described in the Delta P Maintenance Manual.
<b>Delta P Controller ON, but cleaning system does not start</b>	Pressure tubing disconnected, ruptured, or plugged	Check tubing for kinks, breaks, contamination, or loose connections.
	Not wired to the timing board correctly	Connect the pressure switch on the timer board to Terminals 7 and 8 on TB3.
	Faulty relay	Using a multimeter, test relay for proper closure. Replace if necessary.
<b>Delta P arrow keys to not work</b>	Improper operation	Press and hold one of the three setpoint keys to use arrow keys.
	Programming keys disabled	Remove the Program Disable jumper from Terminals 3 and 4 on TB2.





## The Donaldson Torit Warranty

Donaldson warrants to the original purchaser that the major structural components of the goods will be free from defects in materials and workmanship for ten (10) years from the date of shipment, if properly installed, maintained and operated under normal conditions. Donaldson warrants all other Donaldson built components and accessories including Donaldson Airlocks, TBI Fans, TRB Fans, Fume Collector products and Donaldson built Afterfilters for twelve (12) months from date of shipment. Donaldson warrants Donaldson built filter elements to be free from defects in materials and workmanship for eighteen (18) months from date of shipment. Donaldson does not warrant against damages due to corrosion, abrasion, normal wear and tear, product modification, or product misapplication. Donaldson also makes no warranty whatsoever as to any goods manufactured or supplied by others including electric motors, fans and control components. After Donaldson has been given adequate opportunity to remedy any defects in material or workmanship, Donaldson retains the sole option to accept return of the goods, with freight paid by the purchaser, and to refund the purchase price for the goods after confirming the goods are returned undamaged and in usable condition. Such a refund will be in the full extent of Donaldson's liability. Donaldson shall not be liable for any other costs, expenses or damages whether direct, indirect, special, incidental, consequential or otherwise. The terms of this warranty may be modified only by a special warranty document signed by a Director, General Manager or Vice President of Donaldson. To ensure proper operational performance of the equipment, use only genuine Donaldson replacement parts. THERE EXIST NO OTHER REPRESENTATIONS, WARRANTIES OR GUARANTEES EXCEPT AS STATED IN THIS PARAGRAPH AND ALL OTHER WARRANTIES INCLUDING MERCHANTABILITY AND FITNESS FOR A PARTICULAR PURPOSE, WHETHER EXPRESS OR IMPLIED ARE HEREBY EXPRESSLY EXCLUDED AND DISCLAIMED.

[astgroup.ca](http://astgroup.ca)



905-821-8860



**Donaldson.**  
FILTRATION SOLUTIONS