



## Torit Radial Blade Fan

TRB-1 to TRB-10 (60 and 50 Cycle)

### Installation and Operation Manual

Installation, Operation and Service Manual

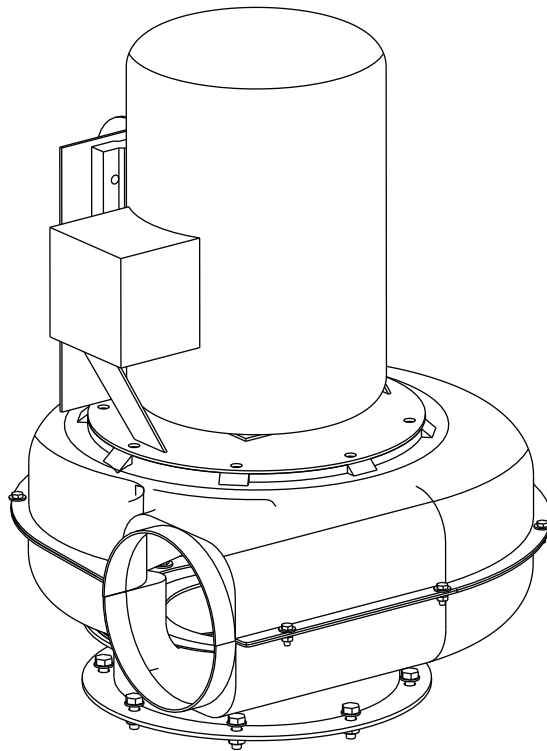

This manual contains specific precautions related to worker safety. The hazard alert image denotes safety related instructions and warnings in this manual. DO NOT install, operate, or perform maintenance on this collector until you have read and understood the instructions, precautions and warnings contained within this manual.

English  
Master Language

IOM AG8130401 (ENG)  
Revision 3

## IMPORTANT NOTES

This manual has been supplied to assist with the installation, operation and maintenance for the collector purchased. Please read the manual before installing, operating, or performing maintenance on the collector as it contains specific precautions for worker safety. It is the owner's responsibility to ensure that this manual is available for use by installers, operators and maintenance personnel that will be working with this collector. This manual is the property of the owner and should be left with the collector when installation has been completed. **DO NOT** operate this collector until you have read and understood the instructions and warnings located in this manual.

For additional copies of this manual, contact Donaldson Torit.



The Safety Alert Symbol indicates a hazardous situation which, if not avoided could result in death or serious injury. Obey all safety messages following this symbol to avoid possible injury or death. The possible hazards are explained in the associated text messages.

### **NOTICE**

**NOTICE** indicates a potential situation or practice which is not expected to result in personal injury, but which if not avoided, may result in damage to equipment.

## Contents

IMPORTANT NOTES .....	i
1 Safety Communication .....	1
2 Product Description .....	3
3 Operation.....	3
4 Product Service .....	4
Motor Maintenance .....	5
Grease Motors .....	5
Wheel Balance .....	5
Vibration .....	5
Troubleshooting .....	6
Appendix A - Installation .....	8
Installation .....	9
Lifting Information .....	10
Storage .....	10
Electrical Wiring.....	10
Fan Installation .....	11
Motor Drain Hole Orientation (for Side Mounted Fans) .....	13
TBI to TRB Fan Adapter Conversion Installation.....	13
Side Mount Fan and Adaptor Installation (for MB collectors) .....	14
Duct Connections and Support.....	15
Top Mount Chamber Silencer .....	15
Start-up / Commissioning .....	16
Decommissioning .....	17
Product Information .....	18
Service Notes .....	19
Donaldson Industrial Air Filtration Warranty.....	20

## 1 Safety Communication



Improper operation of dust collectors and/or dust control systems may contribute to conditions in a work area or facility which could result in severe personal injury, and product or property damage. All dust collection equipment should be used only for its intended purpose and should be properly selected and sized for its intended use.

Process owners have important responsibilities relating to identifying and addressing potential hazards in their processes. When the potential for handling combustible dust exists within a process the process owner should include combustion hazards in their risk management activities and should comply with applicable codes and standards related to combustible dust.

Electrical installation must be performed by a qualified electrician.

This equipment is not designed to support site ducts, piping, or electrical services. All ducts, piping, or electrical services must be adequately supported to prevent injury and/or property damage.

Site selection must account for wind, seismic zone, and other load conditions.

Equipment may reach peak sound pressure levels above 80 dB (A). Noise levels should be considered when selecting collector location.

Most dusts present safety and health hazards that require precautions. Wear eye, respiratory, head and other protection equipment suitable for the type of dust.

Some components may be heavier than they appear. Use appropriate lifting methods to avoid personal injury and/or property damage.

Rotating blades can cause serious injury. Operate equipment only when all guards are correctly and securely in place.

Turn all power off and lock out all power before performing service or maintenance work. It is not unusual for the equipment to be operated from a remote location, so equipment may start or stop unexpectedly.

Keep body, hands and foreign objects away from the inlet, the outlet and the other moving parts of the fan such as shafts, belts and pulleys.

This fan has moving parts that can cause serious bodily injury. Before operating or starting maintenance, read the installation and maintenance instructions provided with this manual and AMCA Publication 410 "Recommended Safety Practices for Air Moving Devices."

## Combustible Dust Hazards

Among other considerations, the current NFPA standards require owners whose processes involve potentially combustible materials to have a current Dust Hazard Analysis, which can serve as the foundation for their process hazard mitigation strategy. Mitigation may include but is not limited to:

- Prevention of all ignition sources from entering any dust collection equipment.
- Selection and implementation of fire and explosion mitigation, suppression, and isolation strategies appropriate for the risks in their process.
- Development and use of work practices to maintain safe operating conditions, and to ensure combustible dust does not accumulate within their plant or process equipment.

Donaldson designs, manufactures, and sells industrial air filtration products for a wide variety of applications. Some applications may include processes or materials with inherent fire and explosion hazards. Donaldson is neither an expert nor a certified consultant in fire, spark, or explosion detection, suppression, or control. Donaldson does not provide engineering consulting services related to process or dust hazard analyses, or code and standard compliance. Complying with applicable codes and standards and managing the risks associated with the process or materials remains the responsibility of the process owner/operator. Donaldson may provide referrals to consultants, suppliers of equipment or services related to the detection and/or mitigation of sparks, fires and/or explosions, but Donaldson does not assume responsibility for any such referrals, nor does Donaldson assume any liability for the fitness of a mitigation strategy or product for a particular installation or application. The process owner's final selection of dust collectors and risk mitigation strategies should be based on the outcome of a Dust Hazard / Process Hazard Analysis performed by the process owner. Although early engagement of a dust collector supplier provides helpful insights on the availability and features of various products, process owners should consult with a combustible dust expert and/or a process safety expert before making actual product and mitigation strategy selections.

Donaldson recommends that all industrial air filtration system designs be reviewed and approved by an expert consultant who is responsible for the integrity of the system design and compliance with applicable codes and standards. It is the process owner's responsibility to understand the risks in their process and mitigate those risks in accordance with all applicable laws, regulations and standards, including those published by the NFPA. Donaldson also recommends that proper maintenance and housekeeping procedures and work practices be evaluated, developed, and followed to maintain any industrial air filtration products in safe operating condition.

Many factors beyond the control of Donaldson can affect the use and performance of Donaldson products in a particular application, including the conditions under which the product is used. Since these factors are uniquely within the user's knowledge and control, it is essential the user evaluate the Donaldson products to determine whether the product is fit for the particular purpose and suitable for the user's application. All products, product specifications, and data (airflow, capacity, dimensions, or availability) are subject to change without notice, and may vary by region or country.

## 2 Product Description

Torit Radial Blade (TRB) Fans provide a convenient, cost-effective method of integrating a fan with a Donaldson® Torit® dust collector. The TRB mounts directly to the clean-air outlet of the dust collector, eliminating costly transition ducts, and reducing the footprint of the system.

## 3 Operation



Electrical work during installation, service or maintenance must be performed by a qualified electrician and comply with all applicable national and local codes.

Turn all power off and lock out all power before performing service or maintenance work.

Check that the collector is clear and free of all debris before starting.

Do not install in classified hazardous atmospheres without an enclosure rated for the application.

The TRB Fans feature a radial blade fan wheel which provides high static pressure. It also has direct drive operation to eliminate maintenance of fan bearings and belts. TRB Fans have computer balanced fan and motor assemblies to ensure vibration-free operation. When mounted to a Donaldson Torit Dust collector, the fan is designed to pull dusty air through the collector to be filtered. Cleaned air then exits the collector via the outlet of the TRB Fan.

### **NOTICE**

The use of a damper or variable frequency drive (VFD) is required to control airflow through the collector. Lack of a control damper or VFD will shorten filter life.

When a variable frequency drive (VFD) is used to control fan operation precautions should be taken to eliminate or reduce any shaft currents which may be imposed on the motor by the VFD as stated per NEMA Mg-1. Part 31.

## 4 Product Service



LOCK-OUT all energy sources prior to performing any service or maintenance on the equipment.

Electrical service or maintenance work must be performed by a qualified electrician and comply with all applicable national and local codes.

Rotating blades can cause serious injury. Operate equipment only when all guards are correctly and securely in place.

Turn all power off and lock out all power before performing service or maintenance work. It is not unusual for the equipment to be operated from a remote location, so equipment may start or stop unexpectedly.

Donaldson Torit TRB fans are manufactured to high standards with quality materials and components. Proper maintenance will ensure a long and trouble-free service life.

The key to good fan maintenance is regular and systematic inspection of all fan parts. Inspection frequency is determined by the severity of the application and local conditions. Strict adherence to an inspection schedule is essential.

### NOTICE

Regular fan maintenance should include the following:

Check the fan wheel for any wear or corrosion, as either can cause catastrophic failures. Check also for the build-up of material which could cause unbalance resulting in vibration, bearing wear and serious safety hazards. Clean or replace the wheel as required.

Lubricate the bearings, but do not over lubricate.

Periodically inspect the shaft for dirt buildup, corrosion and signs of excess stress or fatigue.

During any routine maintenance, all setscrews and bolts should be checked for tightness. See Torque Value Table.

Specifically for side mounted fans (motor horizontal) confirm the motor drain hole will be oriented facing down in the fan installed orientation. If the motor orientation in the TBI fan as-received condition will not have the motor drain hole facing down when installed in the desired side orientation (i.e. forward blast, up blast, aft blast) then:

1. Unbolt the drive plate (with the fan wheel and motor still attached).
2. Rotate the fan wheel/motor/drive plate assembly on the fan case such that the motor drain hole will face downward when the fan is installed in the desired side mount orientation.
3. Re-bolt the fan wheel/motor/drive plate assembly to the fan case.

Note that the fan wheel should remain attached to the motor shaft and the motor should remain bolted to the drive plate and the wheel/motor/drive plate assembly should be rotated as a single assembly.

When the fan is mounted to the collector in the desired side mount orientation confirm that the motor drain hole is facing downward.

### NOTICE

Failure to position the motor drain hole facing downward in the installed fan position may result in damage to the motor.

## Motor Maintenance

TRB Fans typically use motors with sealed bearings that are permanently lubricated for the life of the motor, but other types of motors may have been selected for your fan.

### Grease Motors

Use the following steps for greaseable motors only:

1. Inspect the motor at approximately every 500 hours of operation or every 3 months, whichever occurs first.
2. Keep the motor clean and the ventilation openings clear. If the motor is not properly ventilated overheating can occur.
3. Use an electrical insulation tester to periodically ensure that the integrity of the winding insulation has been maintained. Investigate any significant drop in resistance.
4. Grease the motor bearings using a high grade bearing grease. For standard service conditions ExxonMobil Polyrex™ EM grease is recommended.

Under standard conditions, grease every 5,500 hours. In severe dirt and abrasive dust conditions, grease every 2750 hours. Under extreme conditions, such as an environment with iron dust, grease every 550 hours.

### Wheel Balance

Airstreams containing particulate or chemicals can cause abrasion or corrosion of the fan parts. This is often uneven and can lead to wheel imbalance over time. When such wear is discovered, a decision must be made to rebalance or replace the wheel.

The soundness of all parts should be determined making sure there is no hidden structural damage. The airstream components should also be cleaned to remove any build-up of foreign material. Specialized equipment can be used to rebalance a cleaned wheel that is considered structurally sound.

Balance weights should be rigidly attached at a point that will not interfere with the housing nor disrupt airflow.

### Vibration



The fan blower wheel should be periodically checked for material build-up and/or erosion. If material has built up on any parts of the wheel, it must be removed and cleaned before it is put back into service.

If any parts of the wheel have been eroded, the wheel must be replaced. Failure to perform this inspection can cause excessive vibration that will damage the fan blower and/or motor bearings. When vibration becomes excessive, it will lead to complete fan blower failure that can result in severe personal injury and/or property damage.

The user must determine the frequency of this inspection based on the actual circumstances of their operation, but check the vibration readings should never exceed a 12 month period.

The fan blower was balanced at the factory to comply with ANSI/AMCA Standard 204-05, Category BV-2. However, rough handling in shipment and/or erection, weak and/or non-rigid foundations and misalignment may cause a vibration problem after installation. After installation, the vibration levels should be checked by personnel experienced with vibration analysis and vibration analysis equipment.

**Note:** The fan blower should not be operated if the vibration velocity of the fan exceeds 0.50 inches per second, filter out, with the blower rigidly mounted.

Vibration readings for direct driven fan blowers should be taken on the motor at the top, sides, and end.



## Troubleshooting

Problem	Probable Cause	Remedy
<b>Fan blower and motor do not start</b>	Improper motor wire size	Rewire using the correct wire gauge as specified by national and local codes.
	Not wired correctly	Check and correct motor wiring for supply voltage. See motor manufacturer's wiring diagram. Follow wiring diagram and the National Electric Code.
	Collector not wired for available voltage	Correct wiring for proper supply voltage.
	Input circuit down	Check power supply to motor circuit on all leads.
	Electrical supply circuit down	Check power supply circuit for proper voltage. Check for fuse or circuit breaker fault. Replace as necessary.
	Damaged motor	Replace damaged motor.
<b>Fan blower and motor start, but do not stay running</b>	Incorrect motor starter installed	Check for proper motor starter and replace if necessary.
	Access doors are open or not closed tight	Close and tighten access doors. See Filter Installation.
	Hopper discharge open	Check that dust container is installed and properly sealed.
	Damper control not adjusted properly	Check airflow in duct. Adjust damper control until proper airflow is achieved and the blower motor's amp draw is within the manufacturer's rated amps.
	Electrical circuit overload	Check that the power supply circuit has sufficient power to run all equipment.
<b>Insufficient airflow</b>	Fan rotation backwards	Proper fan rotation is clockwise when viewed from the motor side or counterclockwise when viewed through the inlet cone. See Preliminary Start-Up Check.
	Access doors open or not closed tight	Check that all access doors are in place and secured. Check that the hopper discharge opening is sealed and that dust container is installed correctly.
	Fan exhaust area restricted	Check fan exhaust area for obstructions. Remove material or debris. Adjust damper flow control.
	Filters need replacement	Remove and replace using genuine Donaldson replacement filters. See Filter Replacement.
<b>Excessive vibration</b>	Loose mounting bolts or set screws	Tighten loose bolts or set screws.
	Misalignment or excessive wear of wheel	Align wheel and balance fan.
	Misaligned or unbalanced motor	Balance fan.
	Bent shaft due to mishandling or material impact	Replace motor with bent shaft and rebalance fan.

Problem	Probable Cause	Remedy
<b>Excessive vibration</b>	Externally transmitted vibration	Isolate collector from external vibration.
	Accumulation of foreign material on the wheel	Clean the wheel.
	Excessive system pressure or restriction of airflow due to closed dampers	Open dampers far enough for fan to operate in stable flow regime.
<b>Inadequate performance</b>	Fan running too slowly	Check power frequency against fan motor design frequency.
	Fan wheel rotating in wrong direction or installed backwards on shaft	Proper fan rotation is clockwise from the top of the fan. The fan can be viewed through the back of the motor.
	Poor system design, closed dampers, air leaks or clogged filters	Check system for damper positions leak points. Check filter Delta P.
	Sharp deflection of airstream at fan outlet	Do not place fan discharge next to a wall.
	Missing discharge fittings	Install discharge fittings.
<b>Excessive noise</b>	Fan operating near "stall" due to incorrect system design or installation	Correct system or replace with correctly sized fan.
	Vibration originating elsewhere in the system	Vibration isolate collector from the system.
	Loose accessories or components	Tighten accessories or components.

# **Appendix A - Installation**

## Installation



Electrical Installation (including bonding and grounding of the collector) must be performed by a qualified electrician.

This equipment is not designed to support site ducts, piping, or electrical services. All ducts, piping, or electrical services must be adequately supported to prevent injury and/or property damage.

Do not install in classified hazardous atmospheres without an enclosure rated for the application.

Service must be performed by trained and qualified maintenance personnel.

Turn all power off and lock out all power before performing service or maintenance work. It is not unusual for the equipment to be operated from a remote location, so equipment may start or stop unexpectedly.

Rotating blades can cause serious injury. Operate equipment only when all guards are correctly and securely in place,

## Location and Site Selection



Codes may regulate recirculating filtered air in your facility. Consult with the appropriate authorities having jurisdiction to ensure compliance with all national and local codes regarding recirculating filtered air.

Equipment location must conform to all codes and standards, should be suitable for the type of dust being handled and should ensure easy access for service and utility connections. Site selection must account for wind, seismic zone and other load conditions.

Follow industry practice relative to clean air velocity into a fan.

## Delivery and Inspection

Upon arrival inspect equipment and report any damage to delivery carrier. File any damage claims with the delivery carrier. Request a written inspection report from the Claims Inspector to substantiate all damage claims.

Compare the equipment received with the description of product ordered. Report any incomplete shipments to the delivery carrier and your Donaldson Torit representative.

Turn the fan wheel by hand to see that it rotates freely and does not bind. If dampers are provided, check for free operation of all moving parts.

## Unloading and Positioning



Equipment should be lifted only by qualified crane or fork truck operators.

Failure to lift the equipment correctly can result in severe personal injury and/or property damage.

1. Remove any crates or shipping straps.
2. Lift the packaged collector from transport container.
3. Inspect for any damage and/or missing parts and report to freight carrier.
4. Check for any hardware which may have become loose during shipment and tighten as necessary.

## Lifting Information



Failure to lift the equipment or sub-assemblies correctly can result in severe personal injury and/or property damage.

Only qualified crane or forklift operators should be allowed to lift equipment.

1. Use all lifting points provided.
2. Fans should be lifted by the base, mounting supports, or lifting points only. Never lift a fan by the wheel, shaft, motor, motor bracket, housing inlet, outlet, or any fan part not designed for lifting.
3. Use clevis connectors, not hooks, on lifting slings.
4. Check the Specification Control drawing for weight and dimensions of the collector and components to ensure adequate crane capacity.
5. Use drift pins to align holes in section flanges during assembly.

## Storage

Check dampers for free operation and lubricate moving parts prior to storage. Inspect the stored fan periodically. Rotate the wheel by hand every two weeks to redistribute grease on motor bearing parts.

## Electrical Wiring



Electrical installation, service, or maintenance work must be performed by a qualified electrician and comply with all applicable national and local codes.

Turn all power off and lock out all power before performing service or maintenance work. It is not unusual for the equipment to be operated from a remote location so equipment may start or stop unexpectedly.

Do not install in classified hazardous atmospheres without an enclosure rated for the application.

## Fan Installation



Rotating blades can cause serious injury. Operate equipment only when all guards are correctly and securely in place.

Electrical installation, service, or maintenance work must be performed by a qualified electrician and comply with all applicable national and local codes.

Turn all power OFF and lock out all power before performing service or maintenance work. It is not unusual for the equipment to be operated from a remote location so equipment may start or stop unexpectedly.

Do not operate in classified hazardous atmospheres without an enclosure rated for the application.

Check that the equipment is clear and free of all debris before starting.

Mounting a fan blower on the side of a collector requires a side power adapter to support the weight of the fan blower.

Poorly installed fan blowers may separate from the collector resulting in personal injury and/or property damage.

Do not look into fan outlet to determine rotation. Material may unexpectedly be discharged from the fan. View the fan rotation through the back of the motor.

Do not interchange a power lead with the ground wire. Severe personal injury and/or property damage may result.

### NOTICE

When mounting a fan in an outdoor or high humidity environment, mount the motor with the motor drain holes facing down.

If the fan rotation is reversed, correct the rotation.

To reverse rotation, three-phase power supply: Switch any two leads on the motor junction box.



Do not interchange a power lead with the ground wire. Severe damage or personal injury may result.

TRB fan wheels are dynamically balanced and assembled fans are tested at operating speeds to check the entire assembly for conformance to vibration limits. All fans must be adequately supported for smooth operation.

Safe operating speed is a function of system temperature and wheel design. TRB fans should not be operated above 3,600 RPM.



Do not allow the fan wheel to come loose from the motor as it may cause severe injury or property damage. To ensure proper attachment of the fan wheel:

Tighten all setscrews in fan wheel.

Repeat after 8 hours of operation.

Repeat again after two weeks of operation.

Reference Torque Value Table.

For additional information, contact the motor manufacturer.

Set screws should never be used more than once. If the set screws are loose, they must be replaced. Use only knurled, cup-point screws with a nylon locking patch.

Torque Values for TRB		
Setscrew Size and Number of Threads/Inch	Hex Wrench Size (across flats)	Carbon Steel Setscrew Torque
In.	In.	Lb. - In.
1/4-20	1/8	65
5/16-18	5/32	165
3/8-16	3/16	228
7/16-14	7/32	348
1/2-13	1/4	504
5/8-11	5/16	1104

TRB fans are shipped assembled and partial disassembly is required before installing.

1. Disassemble the TRB by the blower housing fasteners and splitting the blower halves. The motor half contains the motor, half of the blower housing, and the blower wheel.

2. Apply sealant to the collector toward the outside edge of the bolt pattern.

Note: For top-mounted TRB with a blast-gate style damper, install a spacer ring between the blower housing and the collector to provide the necessary clearance for the damper installation.

3. Mount the inlet half of the blower housing (the one without the motor and fan wheel) to the collector using the hardware supplied.
4. Reattach the motor half of the blower housing to the inlet half of the blower housing. Apply sealant around fan case flange to inside of case flange bolt holes before reassembling.
5. Rotate the blower wheel after installation to ensure proper clearance between the inlet cone and the blower wheel.

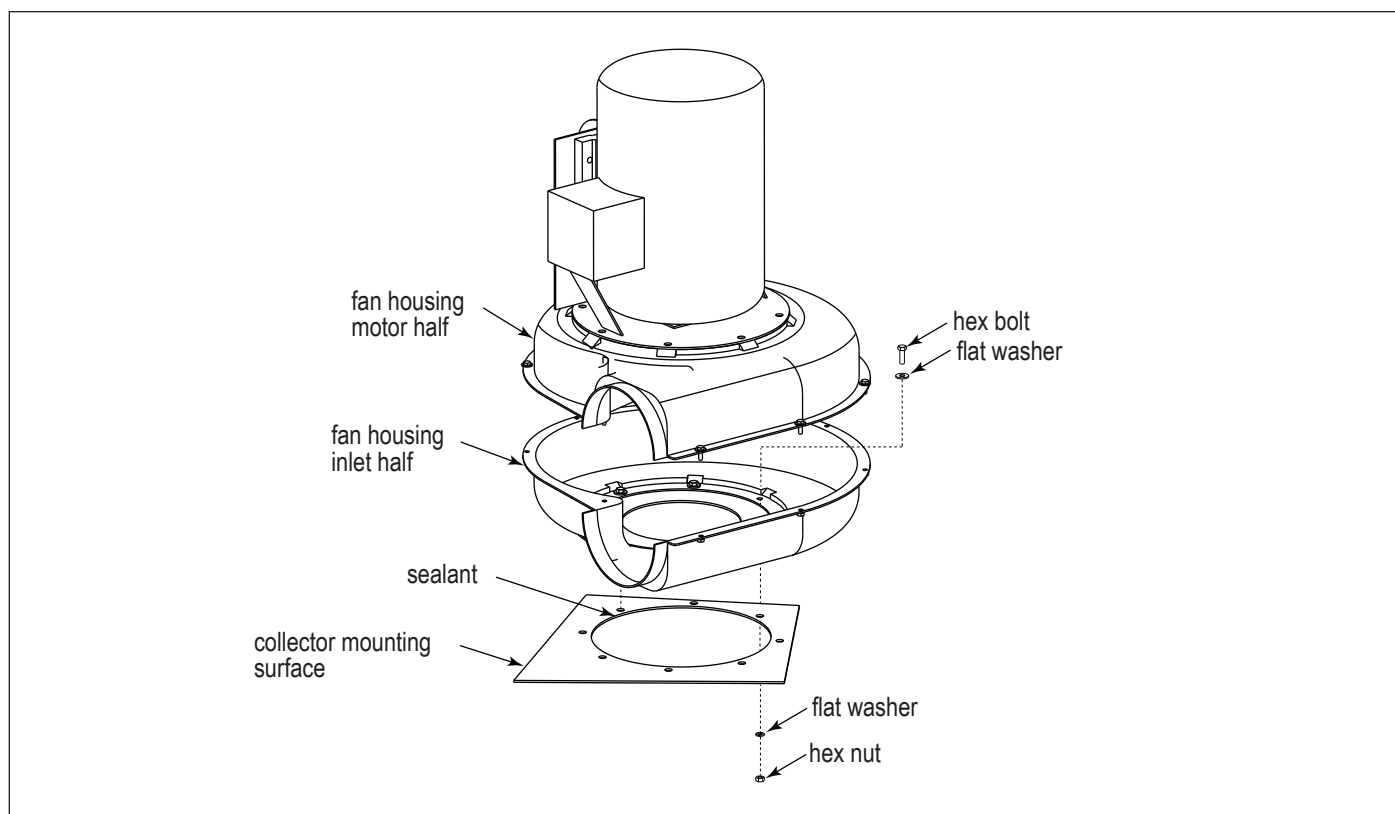

Top Mounted Fan Installation

## Motor Drain Hole Orientation (for Side Mounted Fans)

Motor drain holes must be oriented downward to prevent water accumulation in the motor and extend motor life.

Specifically for side mounted fans (motor horizontal) confirm the motor drain hole will be oriented facing down in the fan installed orientation. Any reorientation of the fan motor is best accomplished while the fan is on the ground.

Install the fan with motor oriented for downward bleed hole orientation and confirm the motor bleed hole is at the bottom of the motor.

If the motor orientation in the fan as-received condition will not have the motor drain hole facing down when installed in the desired side orientation (i.e. forward blast, upblast, aft blast) then:

1. Unbolt the drive plate (with the fan wheel and motor still attached).
2. Rotate the fan wheel/motor/drive plate assembly on the fan case such that the motor drain hole will face downward when the fan is installed in the desired side mount orientation.
3. Re-bolt the fan wheel/motor/drive plate assembly to the fan case.

Note that the fan wheel should remain attached to the motor shaft and the motor should remain bolted to the drive plate and the wheel/motor/drive plate assembly should be rotated as a single assembly.

When the fan is mounted to the collector in the desired side mount orientation confirm that the motor drain hole is facing downward.



Failure to position the motor drain hole facing downward in the installed fan position may result in damage to the motor.

## TBI to TRB Fan Adapter Conversion Installation

1. Install TBI to TRB fan adapter conversion on collector fan mount.
2. Disconnect power supply.
3. Apply 1/4-in diameter rope-type sealant to the outside surface of the fan adapter just outside the edge of the hole pattern.
4. Install the fan housing to the fan adapter using the hardware supplied.
5. Install the motor and fan blower assembly to the fan housing using the original fan hardware and new sealant.
6. Connect power supply to the motor. Turn the fan motor ON then OFF to check motor rotation by referencing the rotation arrow on the blower.

To change rotation on three phase collectors, turn power supply OFF and switch any two leads on the output side of the fan motor starter.



Do not interchange a power lead with the ground wire. Severe personal injury and/or equipment damage may result.

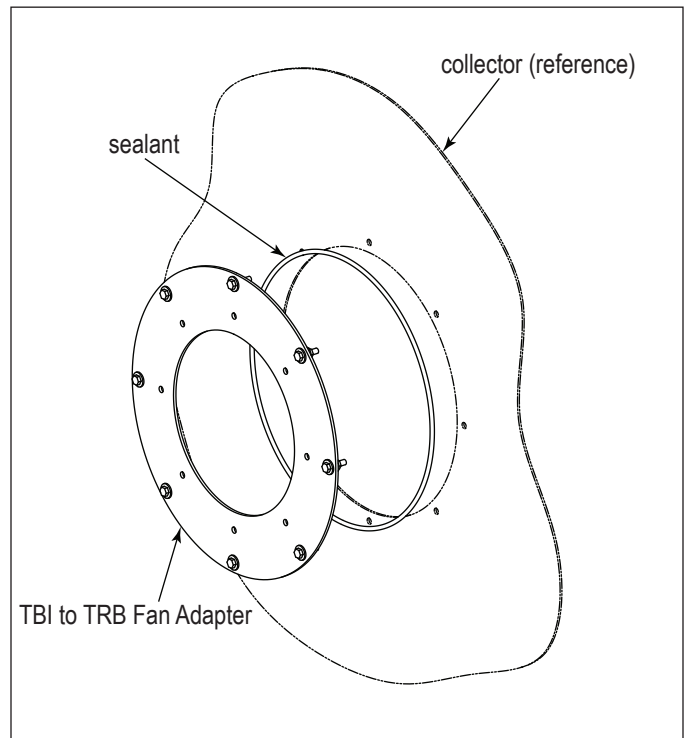

TBI to TRB Fan Adapter Conversion Installation



### Side Mount Fan and Adaptor Installation (for MB collectors)

The side mount fan adaptor allows a TRB/TBI fan blower to be mounted directly to the Modular Baghouse outlet on the rear of the collector housing. It is not designed to be mounted on the outlet of the walk-in plenum. Field assembly of the adaptor is required. This allows the adaptor to be assembled to the outlet location of the customer's choosing.

1. Remove the collector outlet cover.
2. Fasten the TBI to MB outlet adapter to the MB collector outlet using the hardware and sealant provided.
3. Mount the TBI to TRB conversion to the adaptor using the TBI to TRB Fan Conversion Installation Instructions.

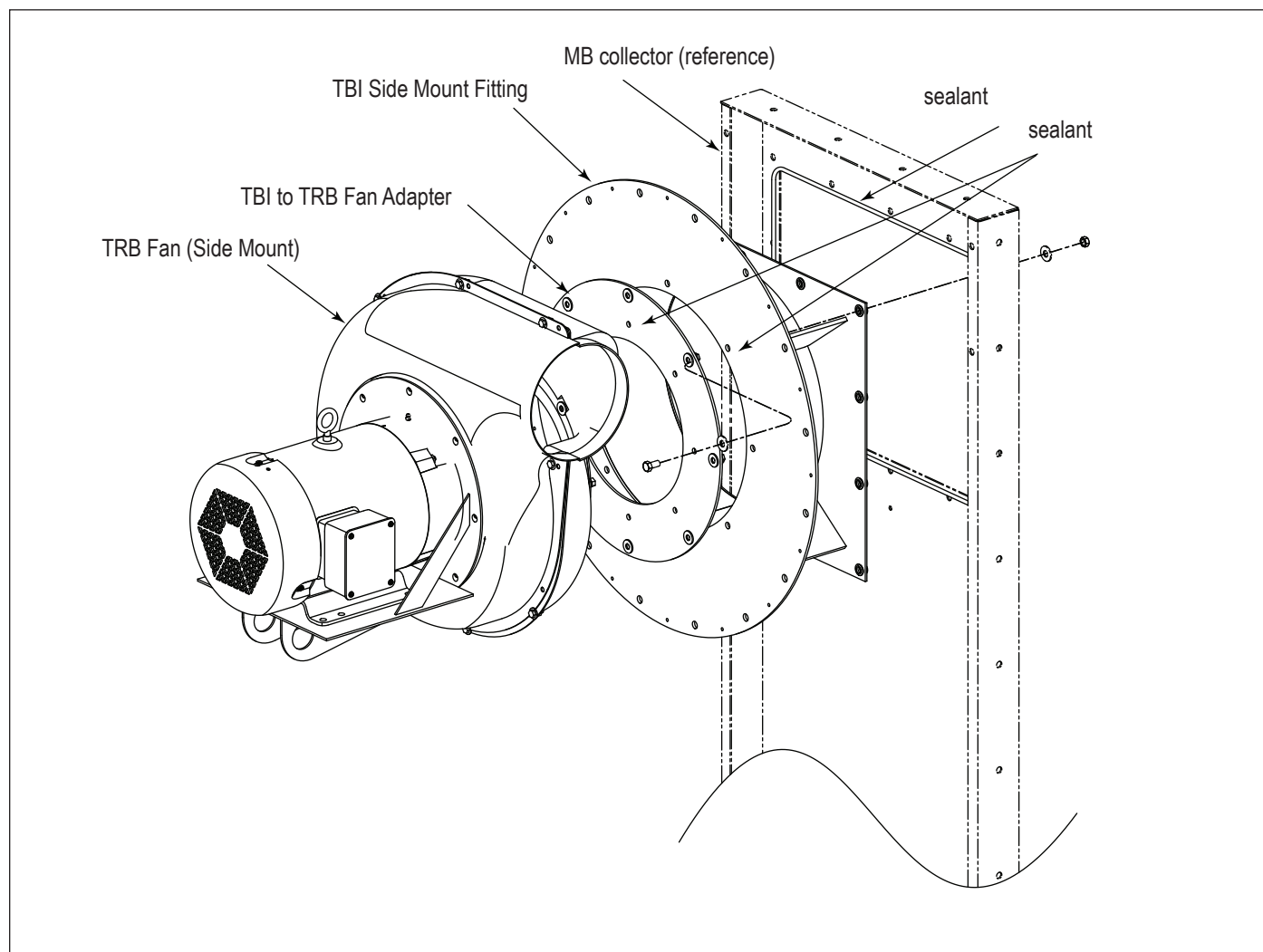

Side Mount Adapter (for MB Collector)

## Duct Connections and Support

Any duct or attenuator/silencer should have independent support. Do not use the fan to support duct or attenuator/silencer. Isolating the fan from duct with flex connections reduces transmission of vibration.

Fans handling hot gases must be rated for operation at the gas temperature and require expansion joints at both the inlet and discharge to prevent excessive loads caused by thermal growth.

## Top Mount Chamber Silencer

1. Apply sealant and attach the bottom panel to the collector as described on the assembly drawing shipped with the silencer using a combination of hardware removed from the collector and supplied hardware.
2. Install the fan and motor assembly as described in this manual.
3. Route rigid or flexible conduit from the junction box on the motor to the outside wall of the silencer to house wiring.
4. Install the top of the silencer and attach silencer to base using the supplied hardware.
5. Loosen the wing nut on the damper and adjust from 30 to 50% closed.

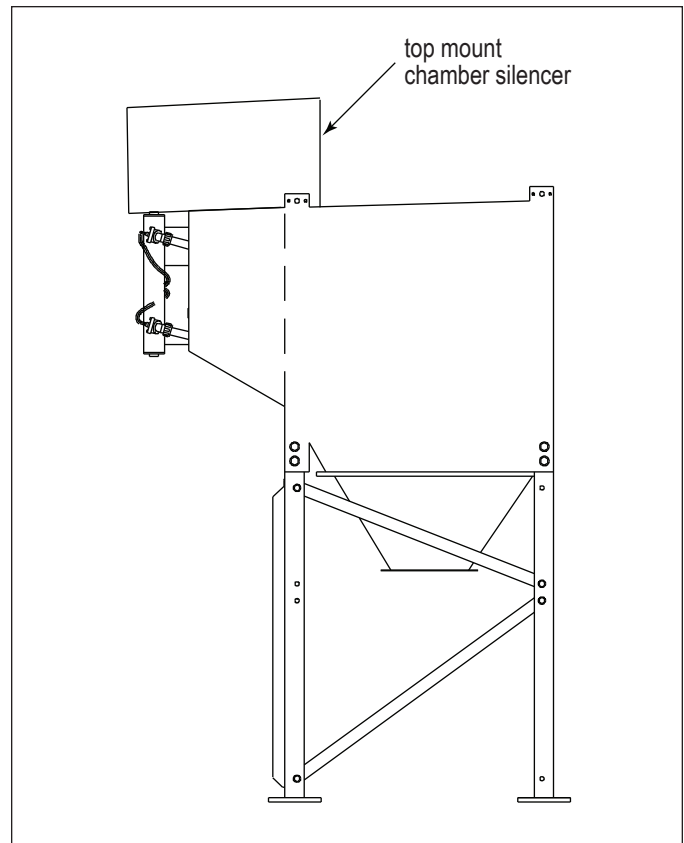

Typical Top Mount Chamber Silencer

## Start-up / Commissioning

Instruct all personnel on safe use and maintenance procedures.



Rotating blades can cause serious injury. Operate equipment only when all guards are correctly and securely in place.

Electrical installation, service, or maintenance work must be performed by a qualified electrician and comply with all applicable national and local codes.

Turn all power OFF and lock out all power before performing service or maintenance work. It is not unusual for the equipment to be operated from a remote location so equipment may start or stop unexpectedly.

Do not operate in classified hazardous atmospheres without an enclosure rated for the application.

Check that the equipment is clear and free of all debris before starting.

1. If possible, carefully spin the fan blower wheel by hand to ensure it rotates freely and no rubbing or clicking noise is heard.
2. Check that all fan blower mounting flange and duct work hardware is tight.
3. Check all fan blower wheel set screws are tight per Torque Values table found in this manual.
4. Ensure any inspection doors in the duct work are securely bolted or locked.
5. Ensure all electrical power components are properly sized and matched for electrical system.
6. Check that all required guards are properly secured.
7. If fan blower is mounted on an elevated support structure, make sure the structure is welded at all joint connections and the structure is properly braced to prevent "side sway".
8. Close any dampers to minimize load on motor, especially on fans with high temperature construction. Never subject a "cold" fan to a "hot" gas stream. If the fan motor will be handling "hot gasses" greater than 150°F (65°C) it is imperative that the fan motor be subjected to a gradual rate of temperature increase, not to exceed 15°F/minute (8°C/minute). The same temperature limits are also important when the fan motor is experiencing a drop in temperature until the temperature drops down to 150°F (65°C). Only when the entire fan motor has reached an equilibrium temperature of 150°F (65°C) or less, should the power be turned OFF.
9. Ensure the power source connections to the fan motor are per the motor manufacturer's instructions.
10. Ensure the fan motor wheel is stationary prior to start-up. Starting a fan motor with a wheel that is rotating backwards can cause wheel damage.



Do not look into fan outlet to determine rotation. View the fan rotation through the back of the motor.

Check that the exhaust plenum is free of tools or debris before checking blower/fan rotation.

Stand clear of exhaust to avoid personal injury.

Do not interchange a power lead with the ground wire. Severe damage or personal injury may result.

- a. Turn fan motor ON momentarily (i.e. bump start) to check for proper fan rotation as noted on the fan housing.

11. If the fan rotation is reversed, correct the rotation.

To reverse rotation, three-phase power supply: switch any two leads on the motor junction box.



Do not interchange a power lead with a ground wire or severe personal injury and/or property damage may result.

## Decommissioning

Once the equipment has reached the end of operational life it will need to be decommissioned.



During decommissioning, there is potential for exposure to the dust in the collector. Most dusts present safety and health hazards that require precautions. Wear eye, respiratory, head, and other protection equipment suitable for the type of dust when performing any decommissioning activities.

LOCK-OUT all energy sources prior to performing any decommissioning activities on the equipment.

Electrical service must be performed by a qualified electrician.

Disconnection of ducts must be performed by a qualified contractor.

1. Lock-Out all energy sources to the equipment.
2. Disconnect the equipment from the exterior of the collector.
3. Dispose of the equipment in accordance with all local codes and regulations.

**Product Information**

(Process Owner to complete and retain for your records)

Model Number _____	Serial Number _____
Ship Date _____	Installation Date _____
Filter Type _____	
Collected Dust _____	
Dust Properties: Kst _____	Pmax _____ MIE _____ MEC _____
Accessories _____	
Other _____	
_____	



## Donaldson Industrial Air Filtration Warranty

Donaldson warrants to the original purchaser only that the Goods will be free from defects in material and manufacture for the applicable time periods stated below: (1) Major structural components for a period of ten (10) years from the date of shipment; (2) Non-Structural, Donaldson-built components and accessories including Donaldson Airlocks, TBI Fans, TRB Fans, Fume Collector products, Donaldson built electrical control components, and Donaldson-built Afterfilter housings for a period of twelve (12) months from date of shipment; and (3) Donaldson-built filter elements for a period of eighteen (18) months from date of shipment.

Buyer is solely responsible for determining if goods fit Buyer's particular purpose and are suitable for Buyer's process and application. Seller's statements, engineering and technical information, and recommendations are provided for the Buyer's convenience and the accuracy or completeness thereof is not warranted. If, after Seller receives written notice, within the warranty period, that any goods allegedly do not meet Seller's warranty, and Seller, in its sole discretion, determines that such claim is valid, Seller's sole obligation and Buyer's exclusive remedy for breach of the foregoing warranty or any Seller published warranty, will be, at Seller's option, either: (i) repair or replacement of such goods or (ii) credit or refund to Buyer for the purchase price from Seller. In the case of repair or replacement, Seller will be responsible for the cost of shipping the parts but not for labor to remove, repair, replace or reinstall the allegedly defective goods. Refurbished goods may be used to repair or replace the goods and the warranty on such repaired or replaced goods shall be the balance of the warranty remaining on the goods which were repaired or replaced. Any repair or rework made by anyone other than Seller is not permitted without prior written authorization by Seller, and voids the warranty set forth herein. Seller warrants to Buyer that it will perform services in accordance with the Sales Documents using personnel of required skill, experience and qualifications and in a professional and workmanlike manner in accordance with generally recognized industry standards for similar services. With respect to any services subject to a claim under the warranty set forth above, Seller shall, in its sole discretion, (i) repair or re-perform the applicable services or (ii) credit or refund the price of such services at the pro rata contract rate and such shall be Seller's sole obligation and the exclusive remedy for breach of the foregoing warranty on services. Products manufactured by a third party ("Third Party Product") may constitute, contain, be contained in, incorporated into, attached to or packaged together with, the goods. Buyer agrees that: (a) Third Party Products are excluded from Seller's warranty in this Section 7 and carry only the warranty extended by the original manufacturer, and (b) Seller's liability in all cases is limited to goods of Seller's design and manufacture only. EXCEPT FOR SELLER'S WARRANTY OF TITLE TO THE GOODS, SELLER EXPRESSLY DISCLAIMS AND EXCLUDES ALL OTHER WARRANTIES WHATSOEVER, WHETHER, EXPRESSED OR IMPLIED, ORAL, STATUTORY, OR OTHERWISE, INCLUDING BUT NOT LIMITED TO MERCHANTABILITY, FITNESS FOR A PARTICULAR PURPOSE, NON-INFRINGEMENT OF THIRD PARTY INTELLECTUAL PROPERTY AND ANY WARRANTIES ARISING FROM TECHNICAL ADVICE OR RECOMMENDATIONS, COURSE OF DEALING OR OF PERFORMANCE, CUSTOM OR USAGE OF TRADE. Seller's obligations do not cover normal wear and tear or deterioration, defects in or damage to any goods resulting from improper installation, accident or any utilization, maintenance, repair or modification of the goods, or any use that is inconsistent with Seller's instructions as to the storage, installation, commissioning or use of the goods or the designed capabilities of the goods or that, in its sole judgment, the performance or reliability thereof is adversely affected thereby, or which is subjected to abuse, mishandling, misuse or neglect or any damage caused by connections, interfacing or use in unforeseen or unintended environments or any other cause not the sole fault of Seller, and shall be at Buyer's expense. Seller's warranty is contingent upon the accuracy of all information provided by Buyer. Any changes to or inaccuracies in any information or data provided by Buyer voids this warranty. Seller does not warrant that the operation of the goods will be uninterrupted or error-free, that the functions of the goods will meet Buyer's or its customer's requirements unless specifically agreed to, or that the goods will operate in combination with other products selected by Buyer or Buyer's customer for its use.

The terms of this warranty may only be modified by a special warranty document signed by a Director, General Manager or Vice President of Donaldson. To ensure proper operational performance of your equipment, use only genuine Donaldson replacement parts.

**This Product is provided subject to and conditioned upon Donaldson's Terms of Sale ("Terms"), a current copy of which accepts these Terms.**

Significantly improve the performance of your collector with genuine Donaldson Torit replacement filters and parts.

**Important Notice:** Many factors beyond the control of Donaldson can affect the use and performance of Donaldson products in a particular application, including the conditions under which the product is used. Since these factors are uniquely within the user's knowledge and control, it is essential the user evaluate the products to determine whether the product is fit for the particular purpose and suitable for the user's application. All products, product specifications, availability and data are subject to change without notice, and may vary by region or country.



[astgroup.ca](http://astgroup.ca)  **AST GROUP OF COMPANIES** 905-821-8860

 **Air Separation Technologies Inc.**  
[astcanada.ca](http://astcanada.ca)

 **AST Engineering Inc.**  
[astengineering.ca](http://astengineering.ca)

 **AST Mechanical Inc.**  
[astmechanical.ca](http://astmechanical.ca)

 **STEVENSON SPRINKLER & Fire Protection Ltd.**  
[stevensonssprinkler.ca](http://stevensonssprinkler.ca)