



# HT SERIES

Feeder valve for screw conveyors, scales, dryers and coolers

## Sizes: 10", 14" & 18"

### STANDARD FEATURES

- Cast iron housing with safety red finish EX version
- Differential pressures up to 40" WC
- Direct drive gearmotor with flex coupling
- Airlock in dust collector and cyclone installations
- Explosion and Flame Proof design rated up to 25 PSI / 670" WC

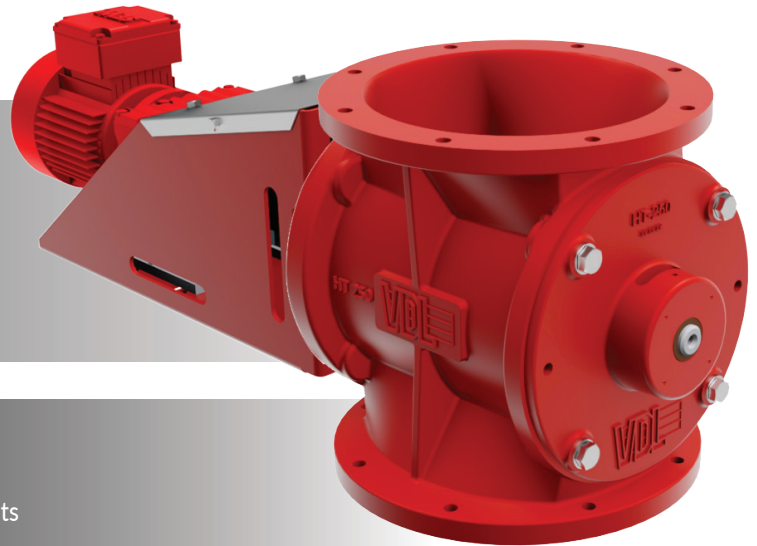

### OPTIONAL FEATURES

- Variable speed drive control option
- Square to round flange adapter including gasket and mounting bolts

### CERTIFICATIONS & STANDARDS



- NFPA 69 Compliant - ATEX Certified EN 15089
- OSHA Compliant drive guard for the Explosion Isolation Model
- Flex tip design certified to prevent flame passage for Passive Explosion Isolation

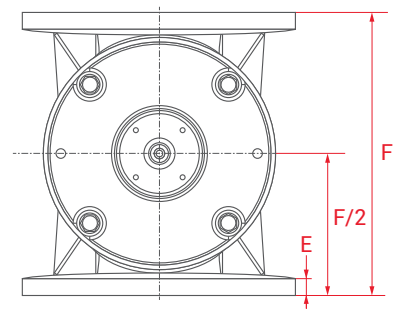
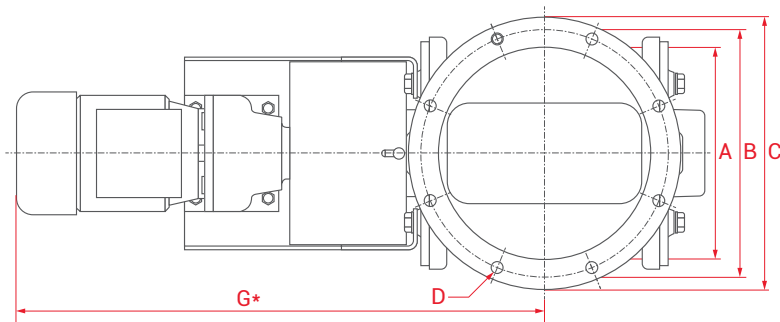

#### DIMENSIONS\*

MODEL	15 RPM HP	30 RPM HP	CAPACITY FT <sup>3</sup> (LTR)	Ø A	Ø B	Ø C	D	E	F*	G
HT250	0.33	0.75	0.24 (7)/rev	10" (250mm)	12" (290mm)	13" (320mm)	8xØ12mm	0.79" (20mm)	13" (330mm)	24" (620mm)
HT350	0.50	1.00	0.70 (20)/rev	14" (340mm)	15" (390mm)	17" (420mm)	8xØ12mm	0.79" (20mm)	16" (400mm)	26" (670mm)
HT450	1.00	2.00	1.23 (35)/rev	17" (420mm)	19" (490mm)	21" (525mm)	8xØ12mm	0.79" (20mm)	20" (500mm)	33" (850mm)

#### SQUARE TO ROUND TRANSITIONS\*

SQUARE TRANSITION(Nominal Size Inches)	6X6	8X8	10X10	12X12	14X14	16X16
SRT	HT250	HT250	HT250	HT350	HT350	HT450
Transition Height	2.84" (72mm)	2.80" (71mm)	2.80" (71mm)	2.80" (71mm)	2.80" (71mm)	3.43" (87mm)
Overall Height (Dim F + Transition Height)	16" (402mm)	16" (401mm)	16" (401mm)	19" (471mm)	19" (471mm)	23" (587mm)

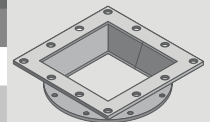

\* Length varies dependent on motor selection – Units in inches rounded to the closest whole number