

Explosion Tested Drum Kit

APPLICATIONS

The NFPA compliant Raptor Drum™ Explosion Tested Drum Kit acts as an extension of the dust collector. It is an innovative solution for explosion isolation. No need for wiring, maintenance, motor, starter, wipers, chains.



copyright 2022 Boss Products, LLC

STANDARD FEATURES

- Standard sizes : 10" -18", 55 gallon or 20 gallon drum

SIMPLE AND PROVEN

- Explosion Tested to 7psi
- NFPA 69/654 Compliant
- Bonded to a Grounded Collector
- No Moving Parts
- No Flex Hose
- Tool Free

DIMENSIONS

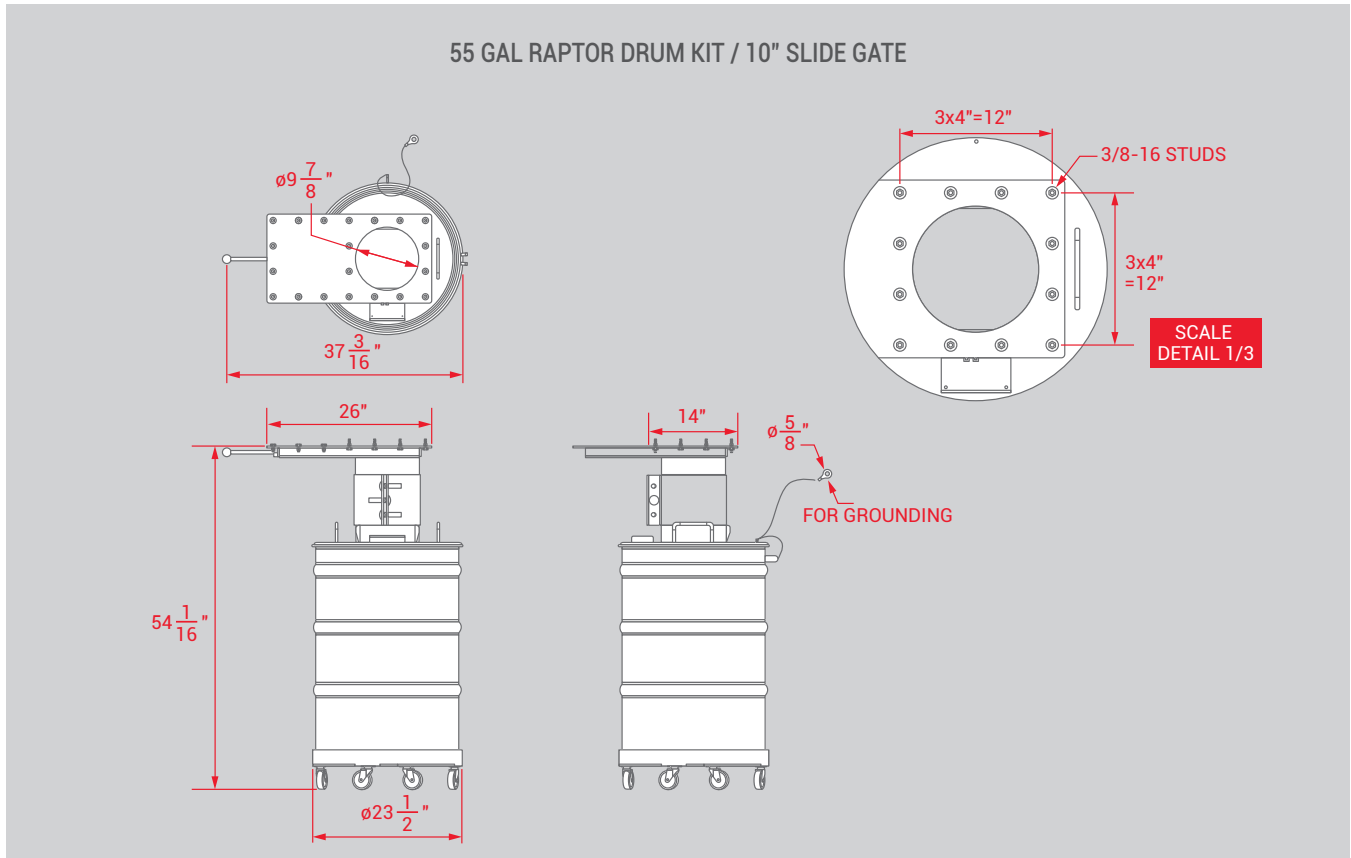

HOW RAPTOR DRUM WORKS

