

POWERLIFT® DIESEL SERIES

PowerLift® Hopper Fill Vacuums

Industrial vacuums designed to be more reliable for you.

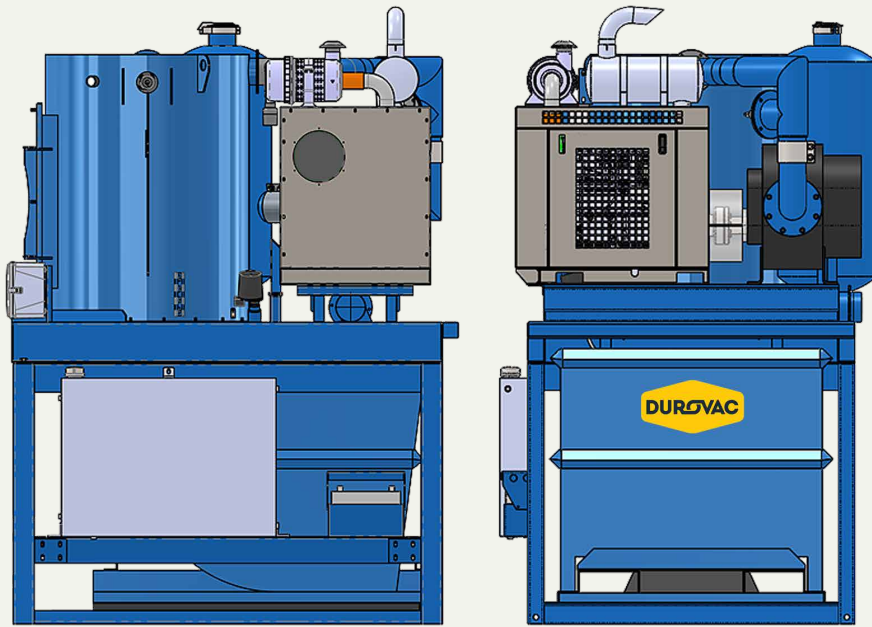

- Filters so good they last years, not months. Low, low cost of ownership.
- Trouble-free operation with super-fine powders, heavy abrasive granules, and wet materials.
- Storage is collected in an easy-to-handle, extreme duty waste hopper.



The diesel PowerLift® vacuum, now built with EPA Tier 4 final engines, lets you cleanup spills anywhere.

PowerLift® by DuroVac moves material fast and keeps your plant or mill clean and safe. This all-in-one package features maximum suction and huge onboard storage. It's perfect for any wet or dry debris that will convey in a hose.

With thousands of configurations, your PowerLift® will have the right horsepower and filtration options for the job. You'll have a 100% customized, high performance vacuum cleaning solution you can depend on.

Let us help you select a durable industrial vacuum that just keeps on working.



The PowerLift® hopper vacuum solves your large cleaning problems. Here's a 31 Hp with a 1.3 yrd³ hopper.

WITH ITS TOUGH, TESTED DESIGN, the PowerLift® lets you vacuum heavy abrasives reliably without internal wear. And the system's onboard storage of up to 2.5 cubic yards means you can tackle production spills and transport them easily by lift truck.

- Exclusive abrasion-proof inlet with hose connections on both sides.
- Self-cleaning filters that last 10x longer than industry standard.
- Easy upgrade to 99.97% HEPA filter.
- Standard NFPA Compliant options.

Specifications

Model Number	PLD25	PLD50	PLD502	PL75	PL75HV
System Horsepower	31 Hp	73 Hp	73 Hp	107 Hp	131 Hp
Number of Hoses	1 x 3.0" 2 x 2.0"	1 x 5.0" 2 x 2.5"	1 x 5.0" 2 x 2.5"	1 x 6.0"	1 x 6.0"
Performance (TPH)¹	4.0	8.0	8.0	12.0	15.0
Air Flow - Inlet (CFM)	525	1050	1050	1550	1550 at 15" Hg.
Vacuum (Maximum)	16" Hg.	16" Hg.	16" Hg.	16" Hg.	24" Hg.
Standard Filter Area (ft²)	85.5	121.0	121.0	207.0	207.0
Pulse Filter Area (ft²)	120.0	210.0	210.0	300.0	300.0
Hopper Volume (Yrd³)	1.33	2.0	2.0	2.5	2.5
Noise Level @ 3ft (dBa)	90	90	90	95	95
Weight (lbs)	4400	6000	7250	7500	8000

1. Performance is rated for foundry sand with a 50 ft long hose. Lighter material moves faster, heavier material slower. Moves 1 lb/min less for every 1 ft longer hose.



Reliable, simple operation with a tough vacuum that just keeps on working.

Designed from the ground up to ensure the lowest possible maintenance, PowerLift® has faster ROI than any other hopper in its class.

Contact us today. We'll take good care of you.

astgroup.ca



AST GROUP
OF COMPANIES

905-821-8860