

Donaldson®
Torit®

**PACKAGED
DOWNFLO® EVOLUTION
DUST COLLECTORS**

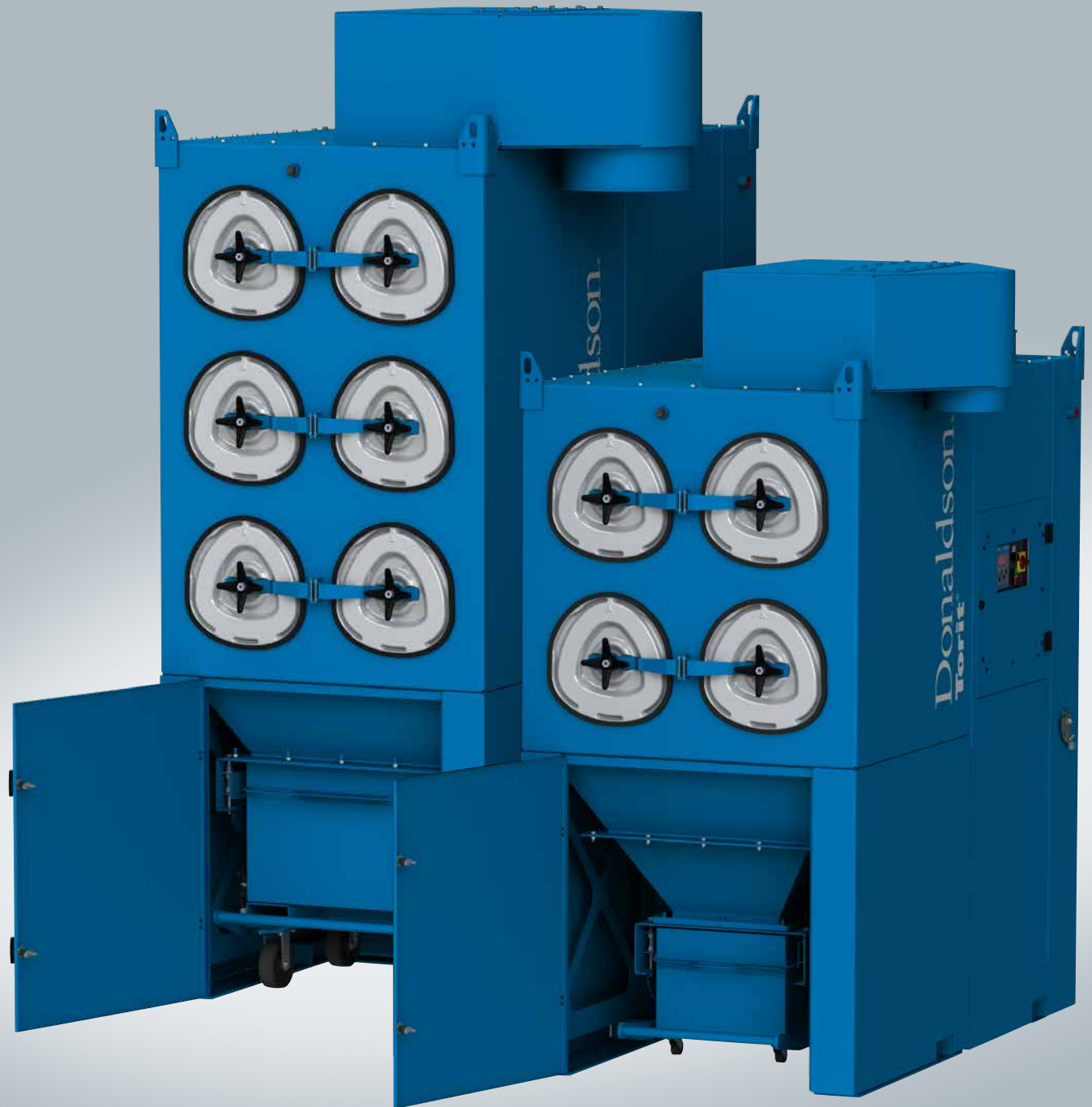

The Complete Plug-and-Play Solution

WE KNOW FILTRATION

Donaldson is a global provider of filtration solutions for manufacturing industries. Our advanced technology, extensive portfolio of filtration products, and unrivaled customer support help manufacturers meet their clean air needs and reduce their long-term cost of operation. Our experience with installations worldwide make us a uniquely qualified partner to provide solutions that support metal fabrication operations.

Power Package

For over 40 years, Donaldson has been at the forefront of cartridge collection and has developed game-changing solutions that include enhanced airflow design, MaxPulse™ cleaning system, triangular filter shape, and industry-leading Ultra-Web® filtration media. Leveraging decades of experience, Donaldson developed the Packaged Downflo® Evolution, which features:

High Production Bin Option

Donaldson offers bin options to support high volume, high production, high capacity applications where minimal downtime for bin dumping is imperative. The larger collection volume provides:

- Maximized production uptime
- Fewer dust collection bin dumps
- Fast, simple dumping
- Wheeled hopper for easy transport
- Same collector footprint
- No additional height or stilts to add



Small Bin
(17 gal / 64 l)

Large Bin
(41 gal / 155 l)

Durable Construction, Clean Aesthetics

Strong and durable, 10/12 gauge, all-welded Packaged Downflo Evolution dust collectors are visually simple and ideal for integration into OEM designs and variety of applications.

Easy Service

Tool-free, hinged access doors allow simple, quick filter change outs.

Flexible

Unit can configure to fit site requirements. Inlet and control placement can be set up to fit specific facility needs.

Easy Dust Disposal

Wheeled bin makes dust clean up simple and easy.

Maximize Space Utilization

Compact size and small footprint, the Packaged Downflo Evolution collectors are available up to 6,000 cfm.





Plug-and-Play Solution

Simple, consolidated, external connections for electricity, compressed air and inlet air ducting.

Downward Airflow Advantage

EPA-sponsored research has shown that "superior performance results from downward flow of the dirty air stream, reducing re-deposition of dust onto filter packs." Donaldson Packaged Downflo Evolution supports dust and fume control on continuous duty applications.

Integrated Controls

Delta P and Delta P Plus Control Panels manage all collector functions, including the fan, filter differential, and pulse cleaning system.

Quiet Operation

Base mounted, high-performance fans minimize noise and exhaust sound abatement design delivers quiet operation.

Energy Efficiency

Superior pulse cleaning design reduces compressed air usage.

Filter Size

Donaldson 26" (66cm) filters are highly efficient while having a smaller size, making filter maintenance quick and easy.

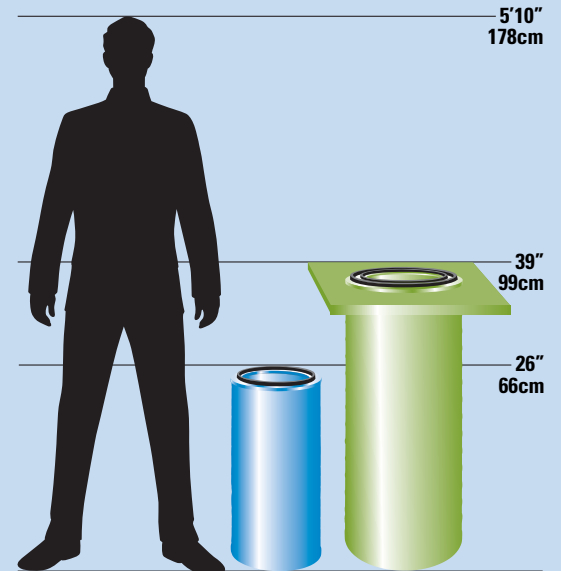

AIRFLOW MANAGEMENT

The Packaged Downflo® Evolution's performance is achieved with a combination of design features that deliver significant customer benefits.

1 Unique Downflow Inlet Location

Simple duct connection provides easy installation of ducting from fabrication process and maximized filtration capacity

2 Even Distribution of AirFlow

Minimizes high velocity air flow, resulting in outstanding performance and long filter life

3 Low Air Turbulance Zone

Lower air velocity at the hopper base enhances dropout of light, fine particles

More Airflow Per Filter

Using Composition Fluid Dynamic modeling to explore design concepts and determine the most effective airflow, engineers designed the Packaged Downflo Evolution to maximize filtration capacity. This provides:

- Maximized uptime
- Extended filter life
- Reduced pressure drop
- Low cleaning energy requirements

OPTIMAL AIRFLOW DISTRIBUTION

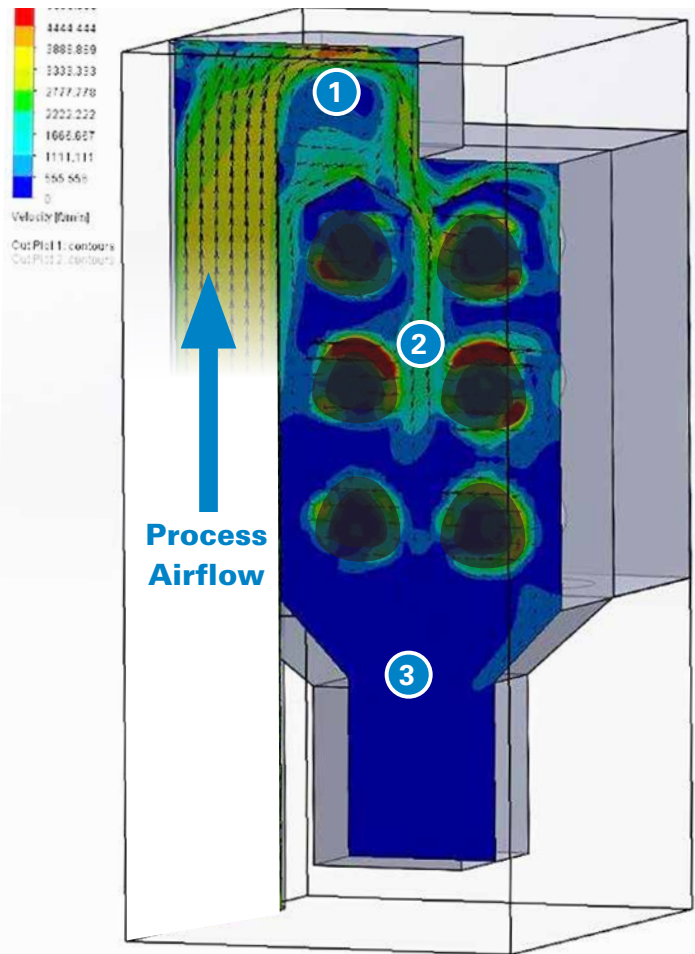

PROVEN RESULTS

Donaldson's proprietary MaxPulse™ Cleaning System enhances cleaning performance, providing improved filtration capacity, maximized filter life and minimized compressed air consumption, resulting in excellent energy efficiency.*

27%
HIGHER
IMPULSE CLEANING
ENERGY DELIVERED

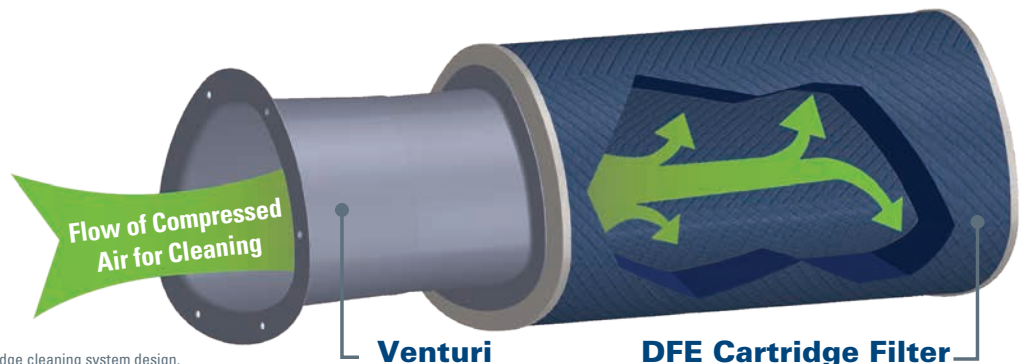

*Improvements base on a comparison to traditional cartridge cleaning system design.

ULTRA-WEB® PERFORMANCE MEDIA

Donaldson's filter design uses Ultra-Web filtration technology, featuring a layer of fine fibers, 0.2 - 0.3 microns in diameter, on the surface of the media to capture sub-micron contaminants. The resulting dust cake is then easily cleaned off during automated cleaning cycles, ensuring cleaner air longer.

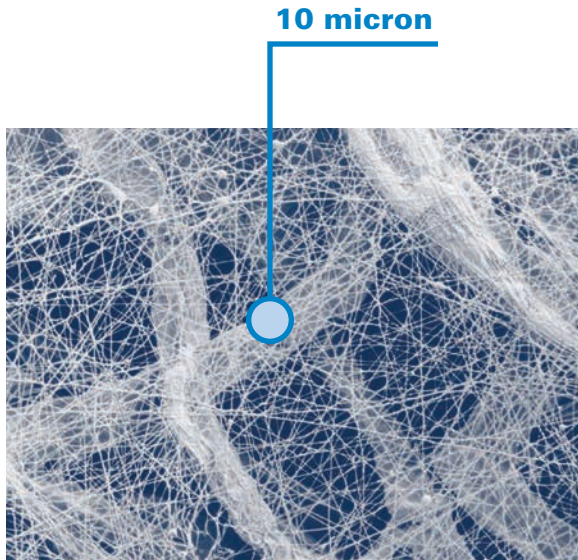

Fine Fiber Media (600x)

Fine fiber surface loading technology is available in all Ultra-Web and Fibra-Web filter cartridges.

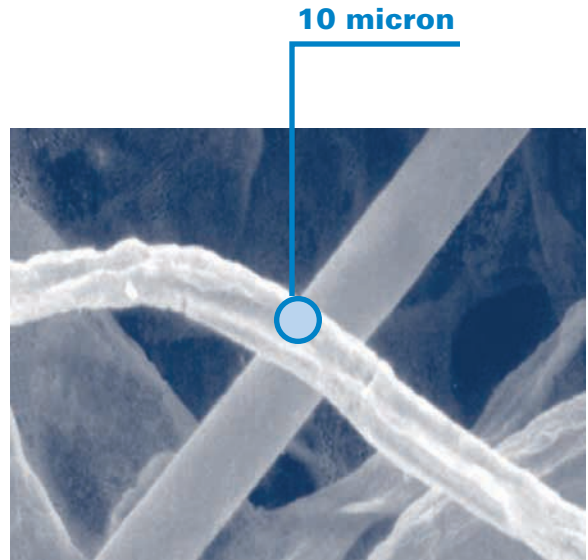

Commodity Filter Media (600x)

Conventional media has spaces of up to 60 µm between fibers, allowing dust to become deeply embedded.

Ultra-Web fine fiber media is the most optimized and cost-effective choice available for most all dust and fume collection applications.

Experience the Ultra-Web advantage:

- Increased surface loading
- Enhanced dust cake release
- Better cleaning efficiency
- Lower cost per cfm
- Available for all popular brands of dust collectors



ULTRA-WEB®



**Three decades of leadership
and over 5 million filters sold**



APPLICATIONS

The Package Downflo® Evolution is effective for a wide variety of applications, including:

- Metal Grinding
- Plasma Cutting
- Laser Cutting
- Welding
- Metal Manufacturing

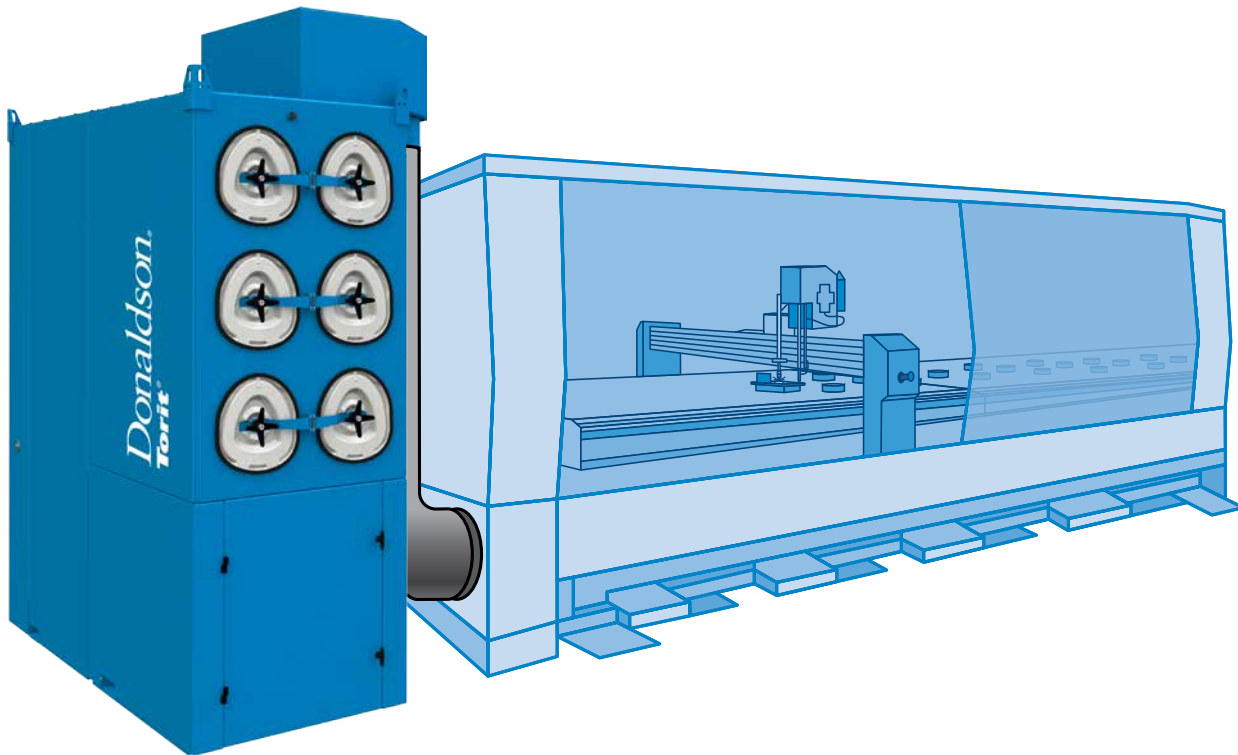

OPERATING CONDITIONS

DFEP Models	DFEP4	DFEP6	DFEP8
Horsepower	7.5 HP & 10 HP	10 HP & 15 HP	10 HP & 15 HP
Sound Level db(A)	71-74 dB(A) depending on HP. Peak pulse noise is 92.7 dB(A)	71-76 dB(A) depending on HP. Peak pulse noise is 92.7 dB(A)	71 - 78 dB(A) depending on HP. Peak pulse noise is 92.7 dB(A)
External Static Pressure	See system performance curves		
Housing Construction	3/16 - 12 gauge steel compliant with IBC2006		
Housing Rating (inches of H ₂ O)	- 25		
Seismic Spectral Acceleration	S _s = 1.5 g S _i = 0.6 g per IBC 2009 FIG 1613.5		
Operating Temperature	150°F/ 66°C		
Control Voltage	120 VAC -or- 24 VDC		
Valves/Controls	60 Hz		

SYSTEM CURVES

The Package Downflo® Evolution system performance graphs show clean filter fan performance. The curves indicate available external static pressure to the unit.

DFEP4 Airflow Curves

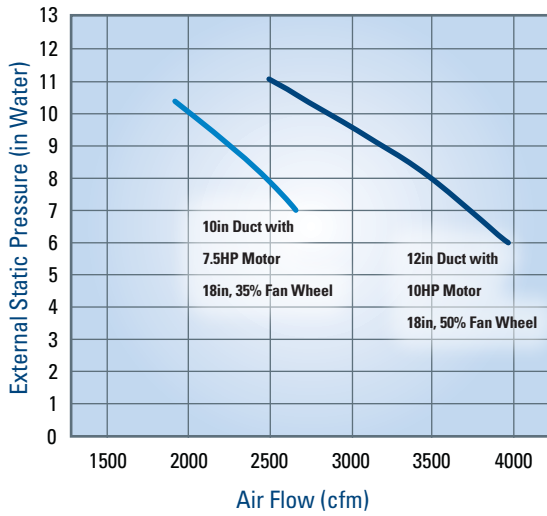

DFEP6 Airflow Curves

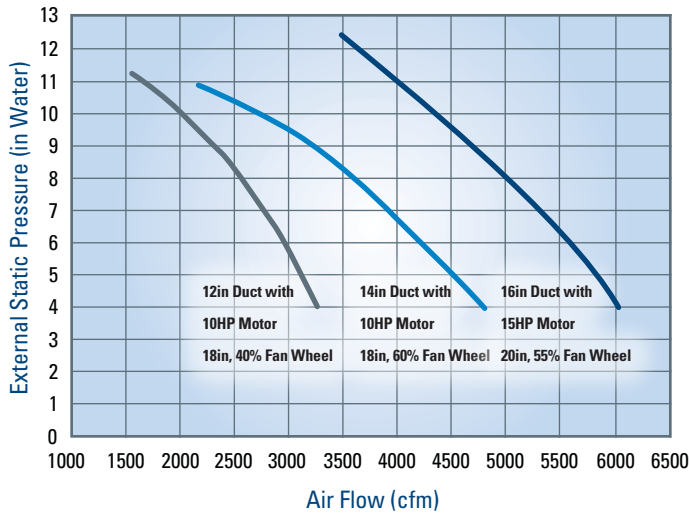

DFEP8 Airflow Curves

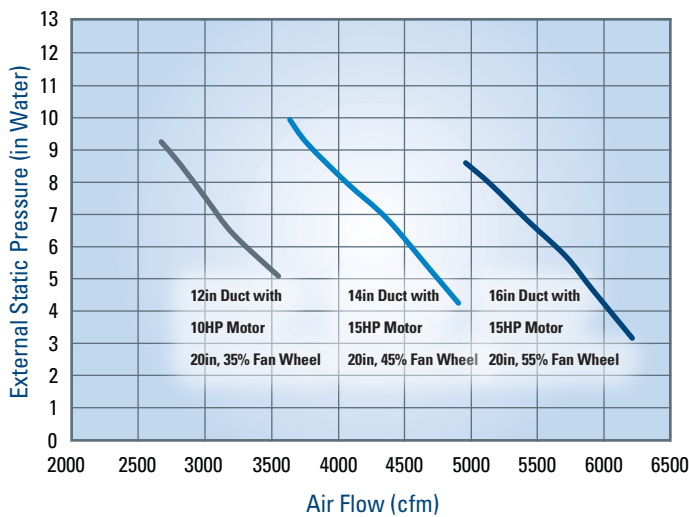

DIMENSIONS & SPECIFICATIONS

MODEL DFEP4

(with Grade Level Duct Inlet)

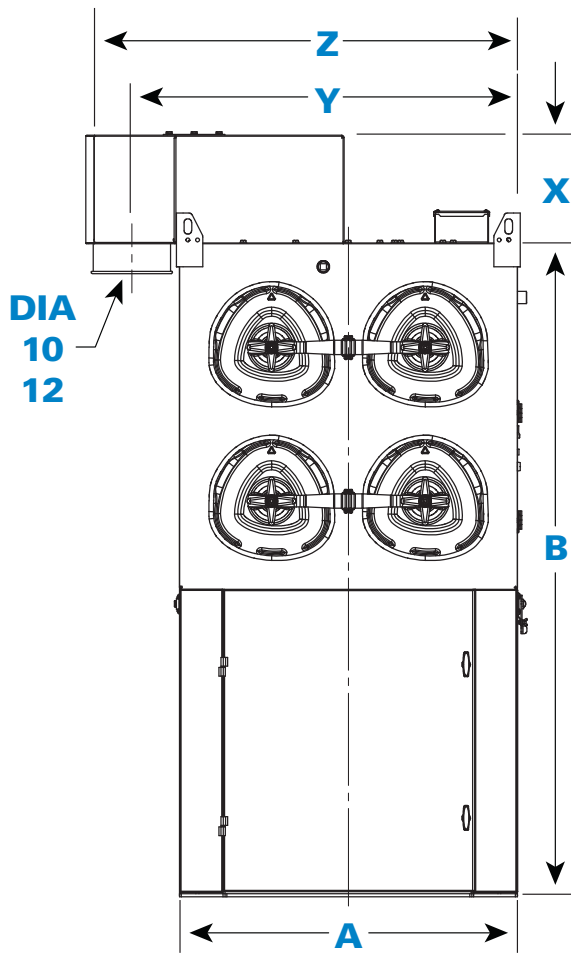

DFEP4 Front View

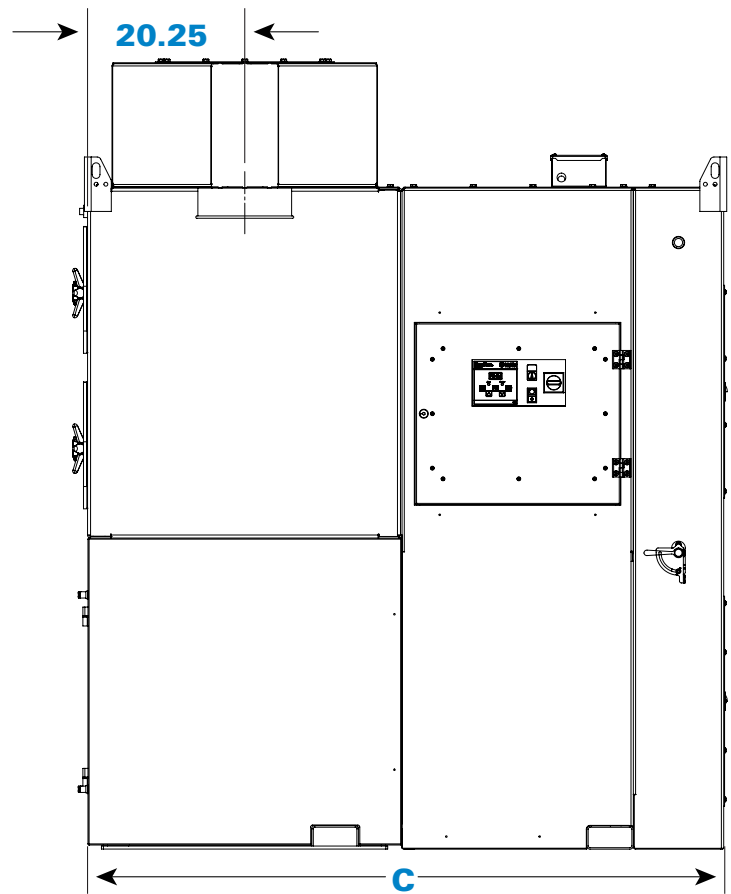

Side View

Model	Nominal Airflow Range* (cfm)	Number of Filter Elements	Filter Media Area (ft ²)	Number of Valves	Dimensions (inches)		
					A	B	C
DFEP4	1800 - 2500	4	1016	4	44.0	85.0	81.8

* Based on clean filters.

Inlet Size (inches)			
DIA	X	Y	Z
10	14.1	50.2	56.2
12	16.1	51.0	58.3

DIMENSIONS & SPECIFICATIONS

MODEL DFEP6

(with Grade Level Duct Inlet)

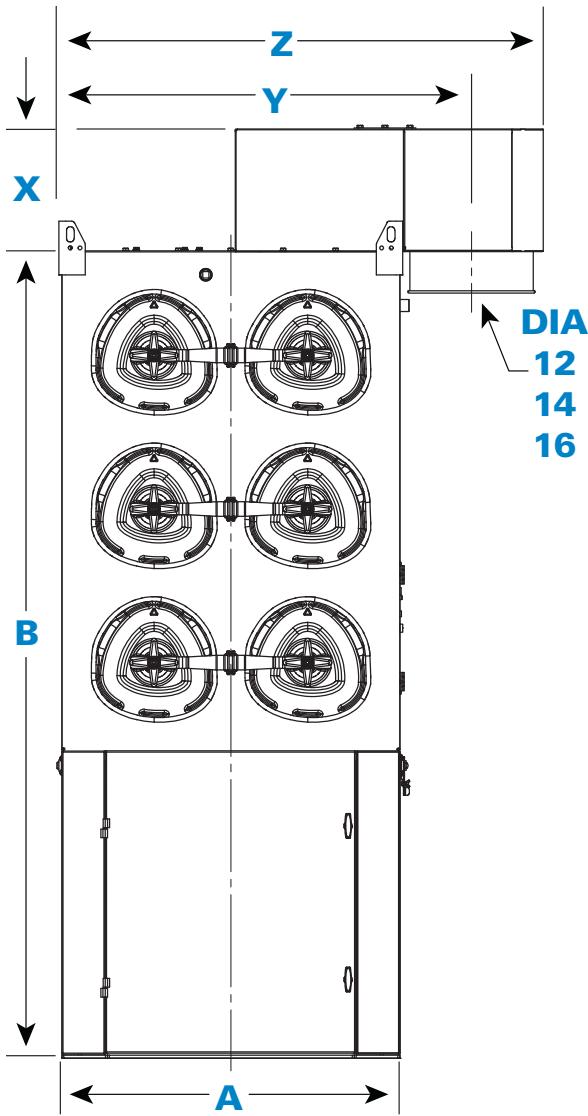

DFEP6 Front View

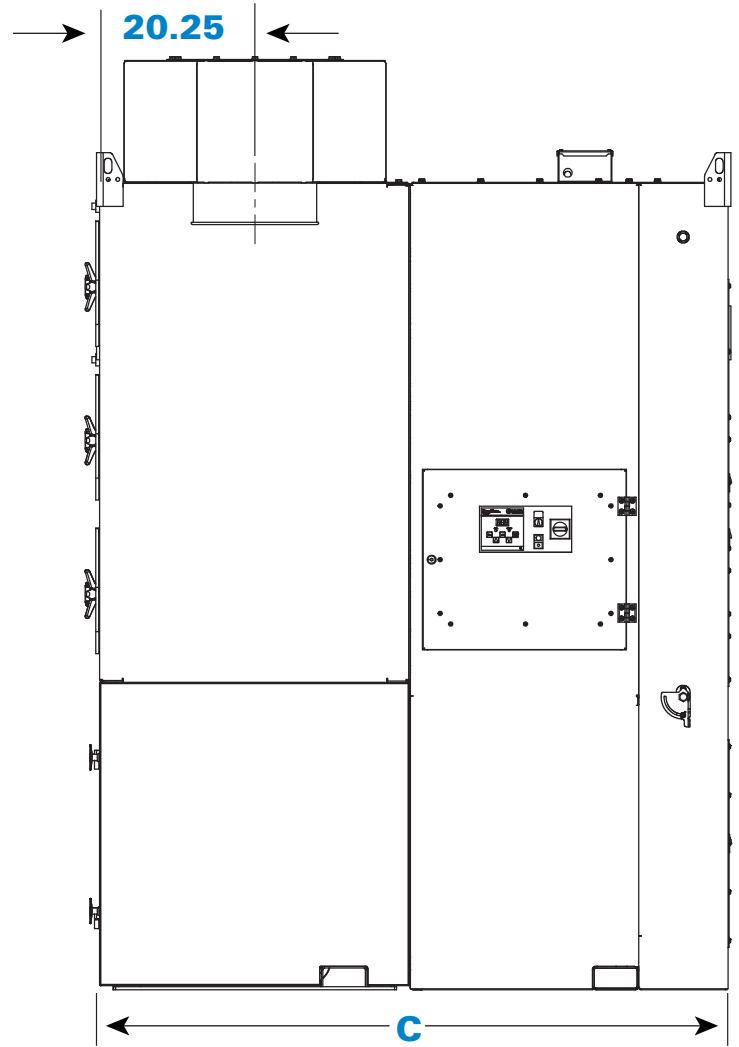

Side View

Model	Nominal Airflow Range* (cfm)	Number of Filter Elements	Filter Media Area (ft ²)	Number of Valves	Dimensions (inches)		
					A	B	C
DFEP6	2500 - 3500	6	1524	6	44.0	105.0	81.8

* Based on clean filters.

Inlet Size (inches)			
DIA	X	Y	Z
12	14.0	51.0	58.3
14	16.0	52.3	60.4
16	16.0	53.3	62.7

DIMENSIONS & SPECIFICATIONS

MODEL DFEP8

(with Grade Level Duct Inlet)

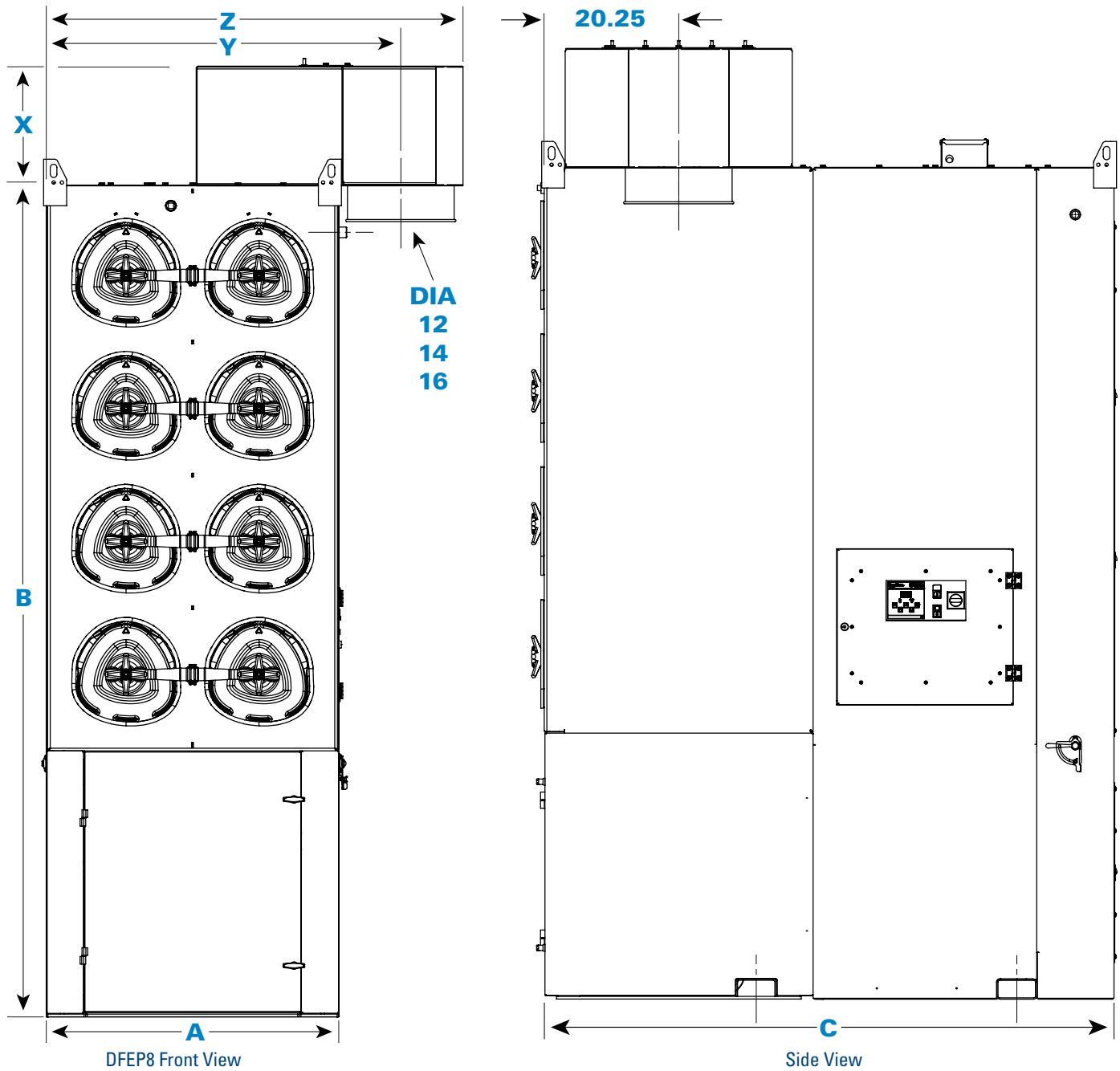

Model	Nominal Airflow Range* (cfm)	Number of Filter Elements	Filter Media Area (ft ²)	Number of Valves	Dimensions (inches)		
					A	B	C
DFEP8	2700 - 6200	8	2032	8	44.0	125.0	85.6

Inlet Size (inches)			
DIA	X	Y	Z
12	16.1	51.0	58.2
14	18.0	52.3	60.3
16	18.0	53.3	62.6

* Based on clean filters.

BENEFITS, FEATURES & OPTIONS

Product Benefits

- Completely Packaged—One-Stop Shopping
- Fully Assembled—Minimal Installation Efforts
- Pre-Wired—Minimal On-Site Wiring
- Smaller Collectors—Save Freight Costs & Space
- Fewer Filter Changes—Less Downtime, Maintenance
- Quiet Energy Efficient Power Packs

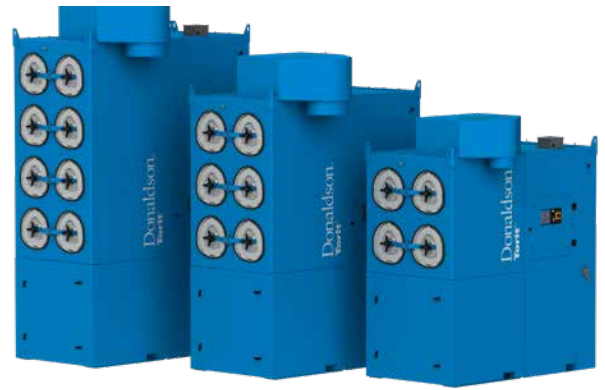

Features & Options

Collector Design ¹ DFEP4, DFEP6 & DFEP8	Std	Opt
Mild Steel Construction	X	
Strong 3/16 to 12 Gauge Mild Steel Structure per IBC2006	X	
Downward Airflow Advantage	X	
Grade Level Duct Inlet	X	
Front, Top Duct Inlet		X
Easy Filter Access – No Tools Required	X	
MaxPulse™ Cleaning System	X	
Premium Efficiency Motors PE	X	
Integrated High-Performance TEFC Fan Packs	X	
Sprinkler Couplings	X	
Built-In Exhaust Silencer	X	
Built-In Damper Valve	X	
Top Exhaust Outlet	X	
Integrated Rear HEPA Filters		X
Rear Weatherhood		X
Top Mount HEPA Filters		X
Safety Equipment		
Side-Mount Explosion Vents per NFPA 68-2013		X
Explosion Suppression		X
Sprinkler Pack		X
Electrical Grounding and Bonding		X
Inline Spark Cooler		X
Fire Suppression		X

Filter Packs	Std	Opt
Ultra-Web® (MERV* 15)	X	
Ultra-Web® FR (MERV* 15); Ultra-Web® SB (MERV* 15); Ultra-Web® AS (MERV* 15); Fibra-Web® (MERV 14); Thermo-Web™ (MERV 14); Torit-Tex™ (MERV 16); High Temp (MERV 13)		X
HEPA/ASHRAE Afterfilters		X
Hopper Discharge		
Small 17-Gallon Dust Bin (DFEP4 & DFEP6)	X	
Large 41-Gallon Dust Bin (DFEP8)	X	
Large 41-Gallon Dust Bin (DFEP4 & DFEP6)		X
Electrical Controls		
Integrated Torit Delta P with Motor Starter	X	
Integrated Torit Delta P Plus with Motor Starter		X
External Remote-Mount Torit Delta P with Motor Starter		X
External Remote-Mount Torit Delta P Plus with Motor Starter		X
with 24VDC START/STOP, Low-Voltage Feedback Relay		X
with Airflow Controller with VFD		X
Integrated Electrical Enclosures NEMA 12	X	
Remote-Mount Electrical Enclosures NEMA 4	X	
Paint System		
Textured Multi-Coat Paint Finish with 2,000-Hour Salt Spray Performance	X	
Premium Duty Finish		X
Custom Colors, Materials and Finishes		X
Warranty		
10-Year Warranty	X	

* The Minimum Efficiency Reporting Value (MERV) of this filter cartridge has been determined through independent laboratory testing using ASHRAE 52.2 test standards. The MERV rating was determined at a face velocity of 118 feet (36.0 meters) per minute and loading up to four inches (101.6 mm) water gauge. Actual efficiency of any filter cartridge will vary according to the specific application parameters. Dust concentration, airflow, particle characteristics, and pulse cleaning methods all affect filtration efficiency.

[†] Donaldson Torit equipment is designed to IBC guidelines for specific wind speed exposure and seismic spectral acceleration at grade level. Contact your Donaldson Torit representative for detailed information available on the equipment's Spec Control drawings. Equipment may be customized to meet unique, customer-specified site requirements.

Industry-Leading Technology

- Advanced filtration technology for optimal performance
- Reduced energy consumption and cost of ownership
- Advanced design and testing capabilities

The Most Filters and Parts

- For every brand and style of collector
- Wide range of filtration media for any application
- 90,000 filters and parts in stock and ready to ship

Unparalleled Support

- Live technical specialists
- Comprehensive pre- and post-sale support
- 40 manufacturing plants and 14 distribution centers worldwide



Donaldson.

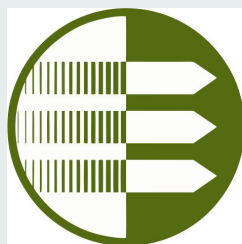

**Air Separation
Technologies Inc.**

905-821-8860 astcanada.ca