



## Mini-Mist Air Filter

MM 500 and MM 1200

### Installation and Operation Manual

Installation, Operation, and Service Information



This manual is property of the owner. Leave with the unit when set-up and start-up are complete. Donaldson Company reserves the right to change design and specifications without prior notice.

Illustrations are for reference only as actual product may vary.



**This is the safety alert symbol. It is used to alert you to potential personal injury hazards. Obey all safety messages that follow this symbol to avoid possible injury or death.**



## APPLICATION OF DUST CONTROL EQUIPMENT

Combustible materials such as buffing lint, paper, wood, metal dusts, weld fume, or flammable coolants or solvents represent potential fire and/or explosion hazards. Use special care when selecting, installing, and operating all dust, fume, or mist collection equipment when such combustible materials may be present in order to protect workers and property from serious injury or damage due to a fire and/or explosion.

Consult and comply with all National and Local Codes related to fire and/or explosion properties of combustible materials when determining the location and operation of all dust, fume, or mist collection equipment.

When combustible materials are present you must consult with an expert in fire extinguishing and/or explosion protection systems, who is also familiar with the local codes, for support and guidance on the selection and installation of an appropriate fire and/or explosion protection system.

DO NOT allow sparks, cigarettes or other burning objects to enter the hood or duct of any dust, fume, or mist collection equipment as these may initiate a fire or explosion of any combustible materials accumulated in the collector.

Portions of dust, mist, and fume-collection equipment, including the clean- and dirty-air plenums may be considered "OSHA Confined Spaces." Refer to the appropriate OSHA regulations to determine if a specific installation should be considered a confined space and if a permit program is required.

Recirculating filtered air in your facility can be a hazard. Consult with OSHA to ensure compliance with all codes regarding recirculating filtered air.

Improper operation of a dust, fume, or mist control system may contribute to conditions in the work area or facility that could result in severe personal injury and product or property damage. Check that all dust, fume, or mist collection equipment is properly selected, installed, and operated for its intended use.

This manual contains specific precautionary statements relative to worker safety. Read this manual thoroughly and comply as directed. Instruct all personnel on the safe use and maintenance procedures related to this equipment. Discuss any questions on the application, use, or maintenance of this equipment with a Donaldson Torit representative.

For optimum collector performance, use only Donaldson Torit replacement parts.

### Data Sheet

Model Number _____	Serial Number _____
Ship Date _____	Installation Date _____
Customer Name _____	
Address _____ _____	
Filter Type _____	
Accessories _____	
Other _____	

**Contents**

Description..... 1

Purpose and Intended Use..... 1

Rating and Specification Information..... 2

Operation..... 3

Inspection on Arrival..... 4

Installation Codes and Procedures ..... 4

    Site Selection, Grade-Mounted Units..... 4

    Site Selection, Ceiling-Mounted Units..... 4

Unit Location..... 5

Rigging Instructions..... 5

    Hoisting Information ..... 5

Electrical Wiring..... 6

Standard Equipment..... 7

    Machine Mount, MM 500 only ..... 7

    Electrical Installation..... 8

    Minihelic® Gauge ..... 8

    Drain Collection Container, MM 1200 only..... 9

    P-Trap or Y-Strainer Installation, MM 1200 only ..... 9

    Inlet Collar, MM 1200 only..... 10

Preliminary Start-Up Check ..... 11

Maintenance Information..... 12

    Operational Checklist ..... 12

    Filter Removal and Installation..... 12

    Split Taper™ Bushing Mounting Instructions ..... 14

Optional Equipment..... 15

    Leg Installation, MM 1200 Only..... 15

    Motor ..... 15

    Hose Kit..... 15

    HEPA Filter..... 15

    Ceiling Installation..... 15

    Wall-Mount Brackets, MM 1200 only ..... 16

Troubleshooting..... 17

Service Notes ..... 18

Minihelic® is a registered trademarks of Dwyer Instruments, Inc.



**DANGER** indicates a hazardous situation which, if not avoided, will result in death or serious injury.



**WARNING** indicates a hazardous situation which, if not avoided, could result in death or serious injury.



**CAUTION**, used with the safety alert symbol, indicates a hazardous situation which, if not avoided, could result in minor or moderate injury.



**NOTICE** is used to address practices not related to personal injury that may result in damage to equipment.

## Description

The Mini-Mist Air Filter, Models MM 500 and MM 1200 are compact, machine-mountable mist collectors designed to filter wet contaminants from machining operations and industrial processes. Primarily used for light- to moderate-duty applications, the Mini-Mist is an excellent choice for machine repair, tool and die, or job shops with small to average production runs.

Three separate filters provide superior filtration of oil, water-soluble and synthetic coolant mist as well as small amounts of dust and smoke. Standard models are designed for 500 to 1200 cfm and feature 1/2 to 1 1/2 horsepower direct-drive blowers. Standard options include multiple motor options, wall- or machine-mount brackets, and HEPA filters all designed to increase the versatility of the unit.

## Purpose and Intended Use

The Mini-Mist Air Filter is primarily used in source capture applications to remove mist and secondary contaminants such as dust and light smoke or fume from machining operations. Two basic means create mist particles: mechanical action and thermal effects. Mechanical action refers to the aerosol used for light lubrication directly from the oil or coolant nozzle. Mechanical action creates mist greater than one micron in size. Thermal effects occur when heat vaporizes the coolant, the vapor cools, and re-condenses into a mist. Thermal effects create submicron mist particles. Select the proper module and filter options for the application.

Types of machining fluids and their applications:

- Straight oil provides the best lubrication qualities but only average cooling properties. Some examples of machining operations using straight oil are cold heading, cold forming, hobbing, and gear cutting.
- Water-soluble coolants consist partly of water and provide the best cooling properties. Examples of applications using water-soluble coolants or soluble oil include broaching, punching, roll forming, and stamping because the tool moves slower and generate less heat.
- Soluble oil or semi-synthetic coolant is used for its equal qualities of cooling and lubricating because the tool is moving fast on close tolerances. Boring, drilling, milling, and lathe turning centers are among the many applications using soluble oil for cooling although milling is the most common.
- Synthetic coolant has superior cooling properties. High-speed operations that generate large amounts of heat require a good coolant. The two main applications are abrasive cut-off sawing and wet grinding including centerless, cylindrical, profile, rotary table, and surface.
- The extremes of very heavy oils and very light, thin oils should be avoided. The very heavy oils, similar to tar consistency, will not drain. Very light, thin oil, similar to gasoline consistency, may evaporate.

### **WARNING**

Combustible materials such as buffing lint, paper, wood, metal dusts, weld fume, or flammable coolants or solvents represent potential fire and/or explosion hazards. Use special care when selecting, installing, and operating all dust, fume, or mist collection equipment when such combustible materials may be present in order to protect workers and property from serious injury or damage due to a fire and/or explosion.

Consult and comply with all National and Local Codes related to fire and/or explosion properties of combustible materials when determining the location and operation of all dust, fume, or mist collection equipment.

Standard Donaldson Torit equipment is not equipped with fire extinguishing or explosion protection systems.

**Rating and Specification Information**

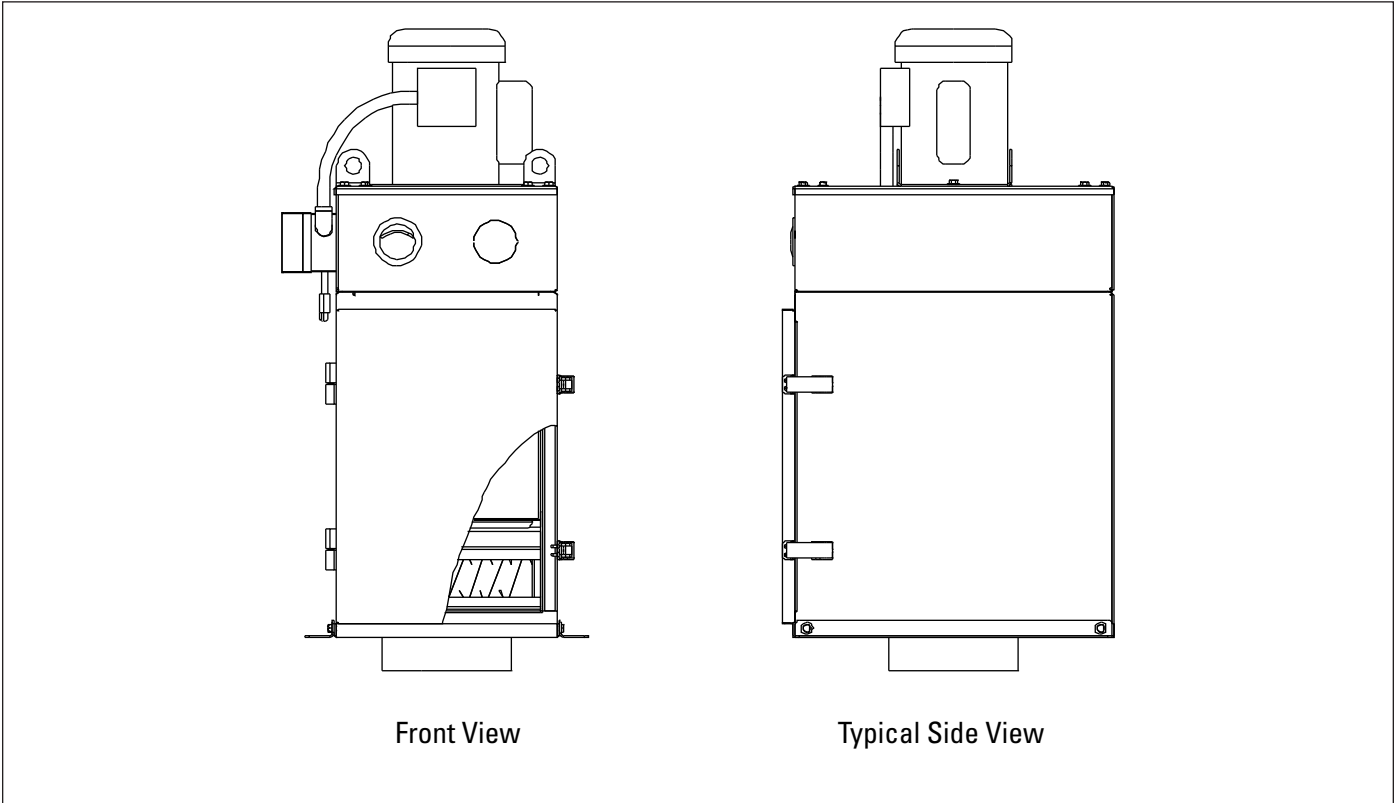

All Units\*:

Housing rating, inches water gauge ..... +/- 20  
 Power and controls .....120-Volt 50/60 Hz

\*If unit was supplied with a Record Drawing, the specifications on the drawing will supersede the standard specifications above.

Specification	MM 500	MM 1200
Electrical Requirements	115/230/50/1	115/230/50/1
voltage/cycle/phase	115/230/60/1	115/230/60/1
	208/230/460/60/3	208/230/460/60/3
	190/380/50/3	190/380/50/3
Nominal Airflow*, cfm	500	120
Blower Motor, plug fan rpm	3450	3450
Motor Horsepower	1/2	1 or 1 -1/2
Box Filter Area, ft <sup>2</sup>	23	58
Approximate Weight, lb	95	165

\*Actual airflow will vary depending on system design

## Operation

During normal operation, the direct-drive blower pulls the contaminated air through the inlet located on the bottom of the unit. Mist enters the first-stage filter, where a large percentage of the mist particles coalesce and drains back into the machine center. The air passes through a

re-usable aluminum-mesh filter before entering the third-stage box filter. Clean, filtered air exhausts out the top of the blower into the work environment. An ON/OFF switch controls the blower and filter maintenance is measured by the Minihelic gauge.

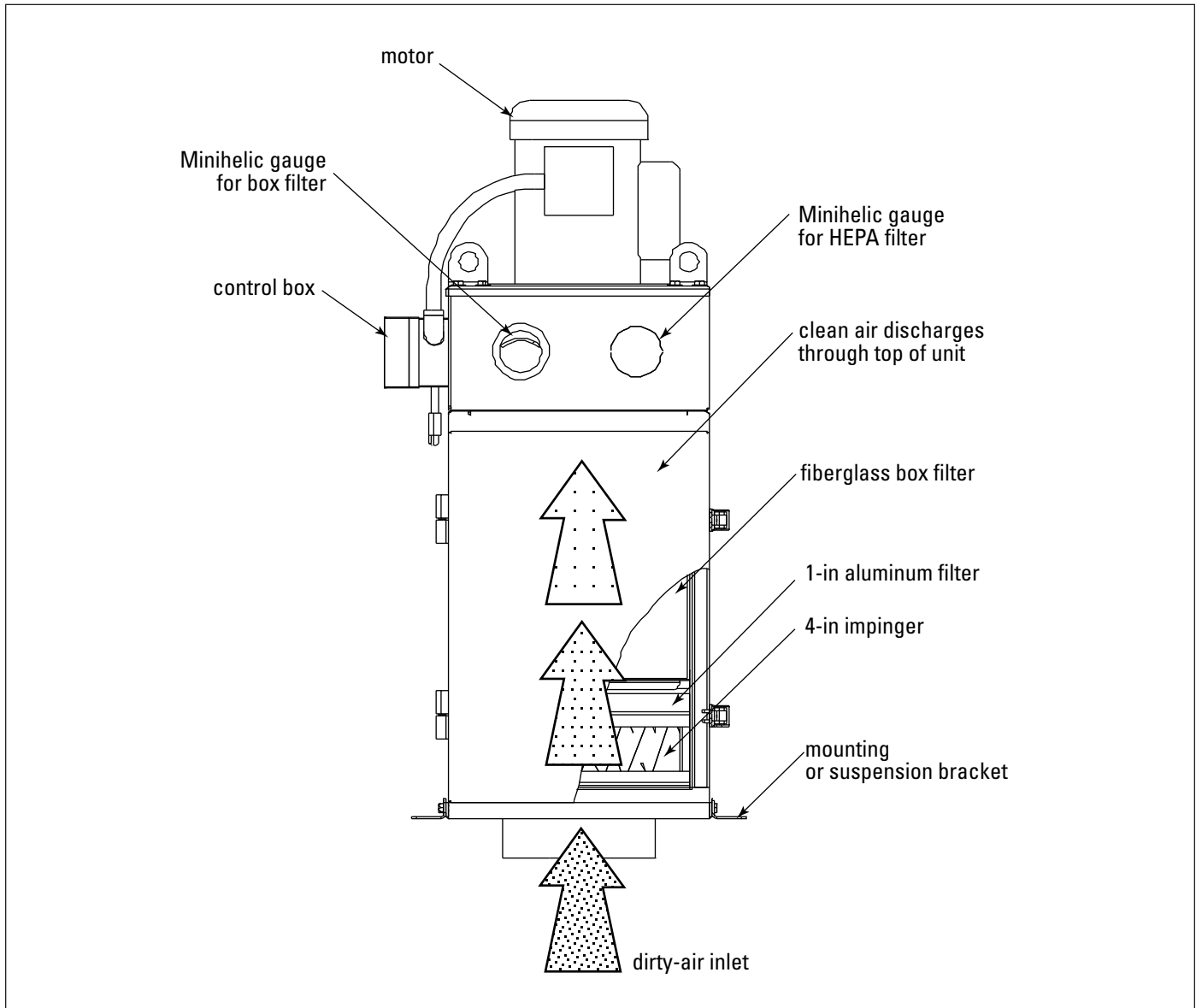

Unit Operation

## Inspection on Arrival

1. Inspect unit on delivery.
2. Report any damage to the delivery carrier.
3. Request a written inspection report from the Claims Inspector to substantiate any damage claim.
4. File claims with the delivery carrier.
5. Compare unit received with description of product ordered.
6. Report incomplete shipments to the delivery carrier and your Donaldson Torit representative.
7. Remove crates and shipping straps. Remove loose components and accessory packages before lifting unit from truck.
8. Check for hardware that may have loosened during shipping.
9. Use caution removing temporary covers.

## Installation Codes and Procedures



Codes may regulate recirculating filtered air in your facility.

Consult with the appropriate authorities having jurisdiction to ensure compliance with all national and local codes regarding recirculating filtered air.

Safe and efficient operation of the unit depends on proper installation.

Authorities with jurisdiction should be consulted before installing to verify local codes and installation procedures. In the absence of such codes, install unit according to the National Electric Code, NFPA No. 70-latest edition.

A qualified installation and service agent must complete installation and service of this equipment.

All shipping materials, including shipping covers, must be removed from the unit prior to, or during unit installation.

### **NOTICE**

Failure to remove shipping materials from the unit will compromise unit performance.

Inspect unit to ensure all hardware is properly installed and tight prior to operating collector.

## Installation



Site selection must account for wind, seismic zone, and other live-load conditions when selecting the location for all units.

Codes may regulate acceptable locations for installing dust collectors. Consult with the appropriate authorities having jurisdiction to ensure compliance with all national and local codes regarding dust collector installation.

### Site Selection, Grade-Mounted Units

The unit can be located on a reinforced concrete foundation.

Provide clearance from heat sources and interference with utilities.

### Site Selection, Ceiling-Mounted Units

The Mini-Mist Filters are not intended for suspended overhead installation. Ceiling mount units require special care to avoid equipment falling. See the Ceiling Installation instructions and notes.

Provide clearance from heat sources and interference with utilities.

## Unit Location



Donaldson Torit equipment is not designed to support site-installed

ducts, interconnecting piping, or electrical services. All ducts, piping, or electrical services supplied by others must be adequately supported to prevent severe personal injury and/or property damage.

When hazardous conditions or materials are present, consult with local authorities for the proper location of the collector

Foundation must be capable of supporting the entire weight of the unit, plus the weight of the collected material, piping, and ductwork.

Prepare the foundation in the selected location. Install anchor bolts to extend a minimum of 1 3/4-inches above foundation.

Locate the collector to ensure easy access to electrical and compressed-air connections and routine maintenance.

## Rigging Instructions

### Suggested Tools & Equipment

Clevis Pins and Clamps	Lifting Slings
Crane or Forklift	Pipe Sealant
Drift Pins	Pipe Wrenches
Drill and Drill Bits	Screwdrivers
End Wrenches	Socket Wrenches
Adjustable Wrench	Spreader Bars
Sealant (Silicone)	
Torque Wrench (inch/lbs, 9/16-in Socket)	

## Hoisting Information



Failure to lift the collector correctly can result in severe personal injury or property damage.

Use appropriate lifting equipment and adopt all safety precautions needed for moving and handling the equipment.

A crane or forklift is recommended for unloading, assembly, and installation of the collector.

Location must be clear of all obstructions, such as utility lines or roof overhang.

Use all lifting points provided.

Use clevis connectors, not hooks, on lifting slings.

Use spreader bars to prevent damage to units casing.

Check the Specification Control drawing for weight and dimensions of the unit, subassemblies, and components to ensure adequate crane capacity.

Allow only qualified crane operators to lift the equipment.

Refer to applicable OSHA regulations and local codes when using cranes, forklifts, and other lifting equipment.

Lift unit and accessories separately, and assemble after unit is in place.

Use drift pins to align holes in section flanges during assembly.



## Electrical Wiring



Electrical work must be performed by a qualified electrician and comply with all applicable national and local codes.

Turn power off and lock out electrical power sources before performing service or maintenance work.

Do not install in classified hazardous atmospheres without an enclosure rated for the application.

1. All electrical wiring and connections, including electrical grounding, should be made in accordance with the National Electric Code, NFPA No. 70-latest edition.
2. Check local ordinances for additional requirements that apply.
3. The appropriate wiring schematic and electrical rating must be used. See unit's rating plate for required voltage.
4. If the unit is not furnished with a factory-mounted disconnect, an electric disconnect switch having adequate amp capacity shall be installed in accordance with Part IX, Article 430 of the National Electric Code, NFPA No. 70-latest edition. Check unit's rating plate for voltage and amperage ratings.
5. Refer to the wiring diagram for the number of wires required for main power wiring and remote wiring.

## Standard Equipment

### Machine Mount, MM 500 only

1. Remove the inlet plenum.
2. Using the inlet plenum as a template, cut a round hole in the top of the machine center.
3. Attach the inlet plenum to the machine center with the welded collar inside the hole cut in Step 2. Use a low-bonding, oil resistant sealant to make an air- and oil-tight seal between the plenum and the machine enclosure.
4. Attach the angle bars to the machine center.
5. Lift the unit into position over the machine center and lower slowly. Align the holes in the angle bars with the holes in the collector.
6. Use the gasket included to create an air- and oil-tight seal between the inlet plenum and the bottom of the collector.
7. Secure the collector to the machine center using four 3/8-16 x 1-in bolts through the angle bracket and plenum into the machine center.

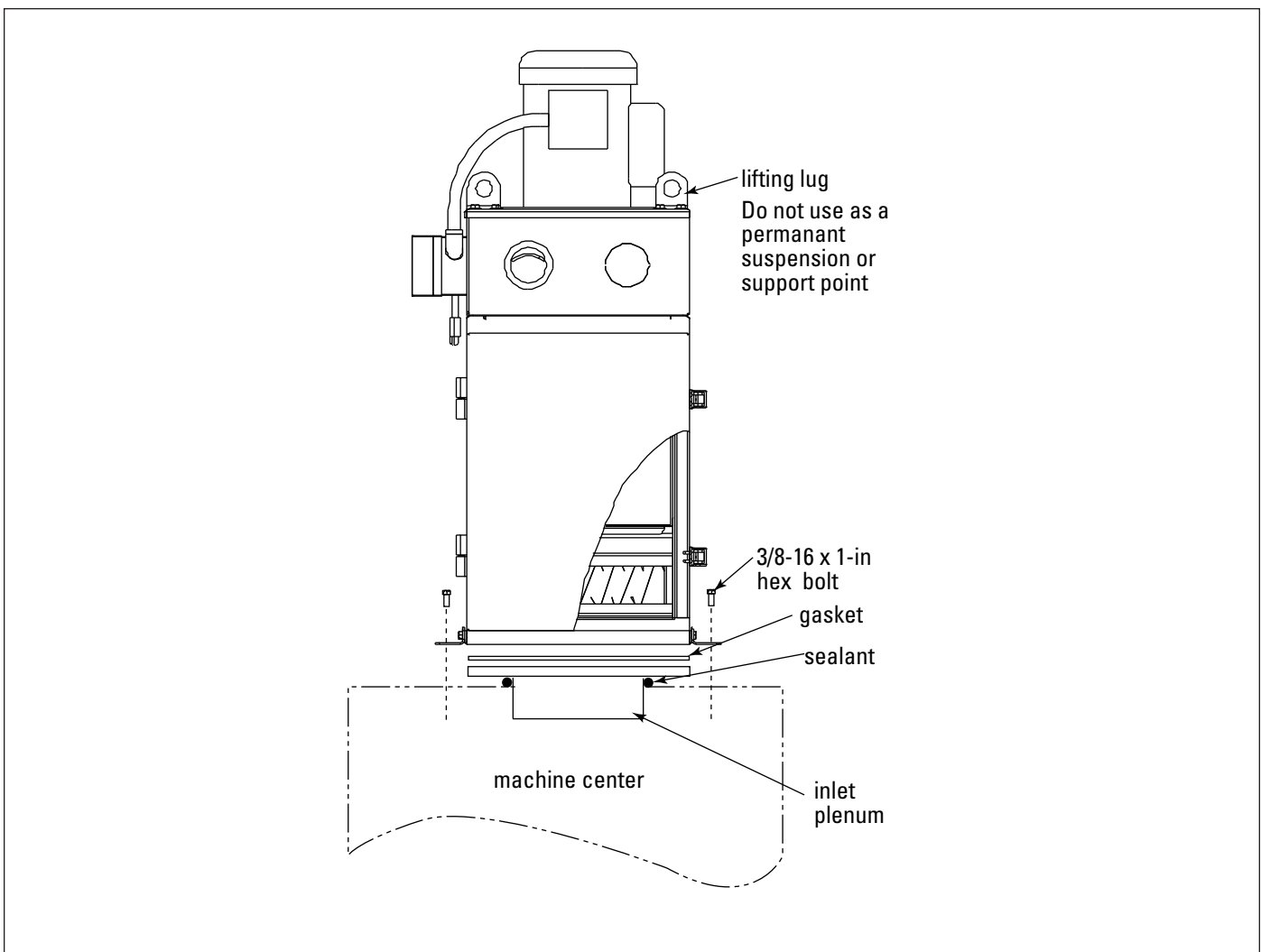

MM 500 Machine Mount

## Electrical Installation

All Mini-Mist Air Filters must be equipped with a customer-supplied safety disconnect with short-circuit protection, contactors, and overload protection.

1. Make the wiring connections to the fan motor according to the wiring diagram located inside the control box and the instructions on the motor decal.

Note: All electrical components must be sized for the supply voltage and motor horsepower.

2. Turn the fan-motor ON then OFF and check for proper rotation by removing the inspection cover located on top of the unit. Proper rotation is counterclockwise.

To reverse rotation, single-phase power supply:  
Follow manufacturer's instructions on the motor's nameplate.

To reverse rotation, three-phase power supply:  
Turn electrical power OFF at source and switch any two leads on the output-side of the fan-motor starter.

## Minihelic® Gauge

The Minihelic is a differential pressure gauge used to measure the pressure difference between the clean- and dirty-air plenums and provides a visual display of filter change requirements.

1. Install the gauge following the manufacturer's installation instructions.
2. Turn unit ON and document the pressure reading. This is the initial operating point of your system, representing clean filter operation.

3. Periodically check the filters to establish the maintenance requirements for the specific application. All applications will be different based on the operating conditions and load potential of the machinery being served. As the filters load, the system resistance increases, and the pressure indicator increases.

Note: Monitor all filters initially. Not all filters have the same replacement cycle because they are designed for different efficiencies and extend the life of the third-stage filter. Also, note that as the filters load, system suction pressure decreases.

4. When observation or insufficient airflow indicates filter maintenance, document the reading of the pressure gauge. This pressure reading represents filter maintenance required. Because not all filters load at the same rate, the operator determines which filter to use as a guide for planned maintenance. When this is established, use the setscrew on the front of the gauge to set the systems operating range.

### Drain Collection Container, MM 1200 only

1. Install the drain collection container during leg installation or after unit is in its final operating position.
2. Turn unit OFF.
3. Remove the container by unscrewing the container from the cap. Clean the container, faucet, and re-install.

Note: Close the faucet before turning the collector back ON.

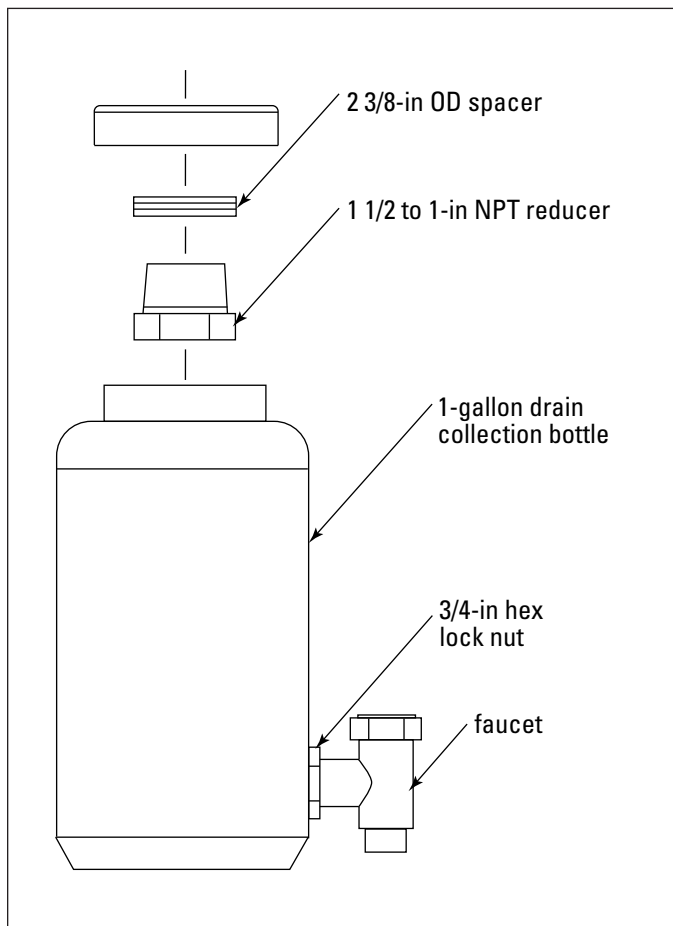

Drain Collection Container

### P-Trap or Y-Strainer Installation, MM 1200 only

1. Install the 1 1/2-in NPT pipe as shown in P-Trap Installation.
2. Plumb the P-Trap to a receptacle or install a return line back to the machine center.
3. Fill P-Trap before starting unit.

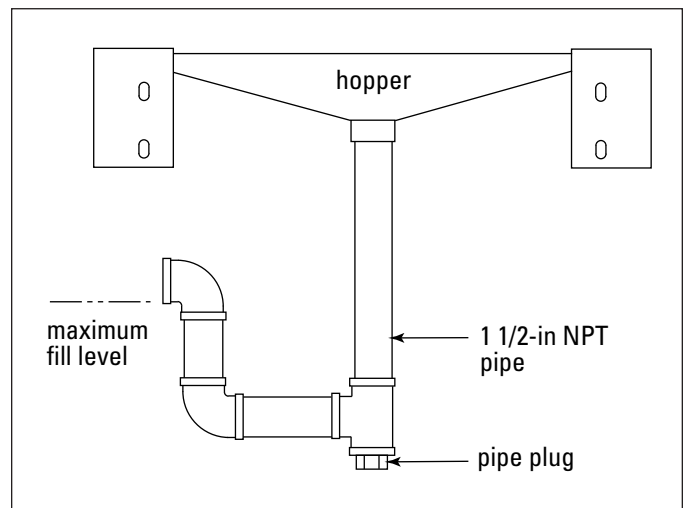

P-Trap Installation

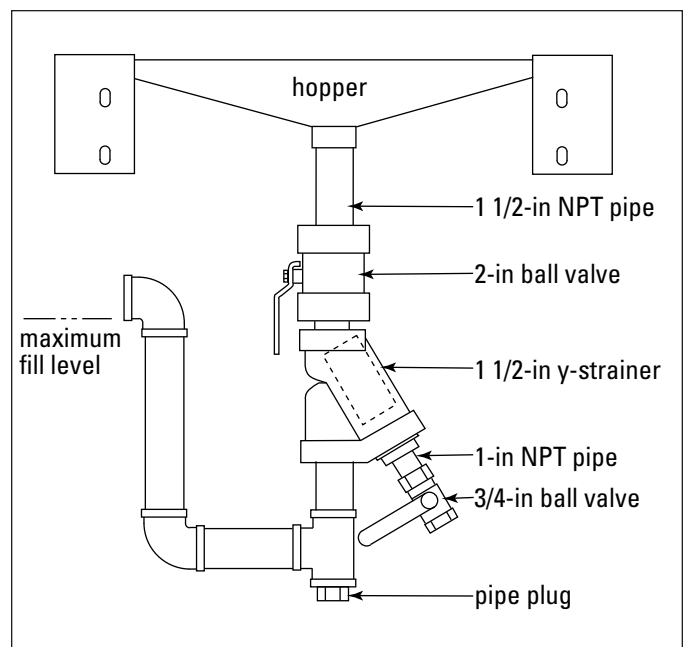

Y-Strainer Installation

## Inlet Collar, MM 1200 only

Inlet collars are shipped loose with gasket and hardware attached. They are installed on one of the four inlet locations on the plenum.

1. Remove one inlet cover plate.
2. Install the inlet collar using the gasket provided and secure using #7 x 1/2-in self-tapping screws supplied.

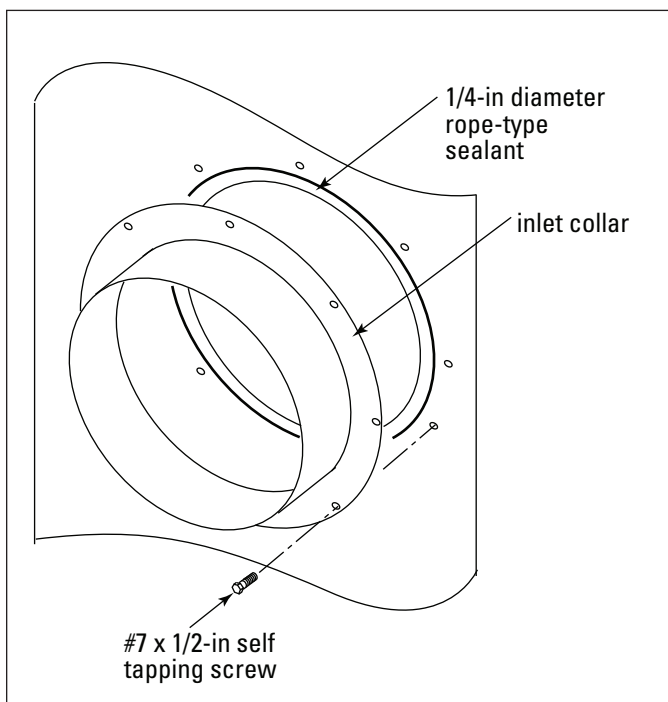

Inlet Collar

## Preliminary Start-Up Check

Instruct all personnel on safe use and maintenance procedures.

### **WARNING**

Electrical work during installation must be performed by a qualified electrician and comply with all applicable national and local codes.

Turn power off and lock out electrical power sources before performing service or maintenance work.

Check that the collector is clear and free of all debris before starting.

Do not install in classified hazardous atmospheres without an enclosure rated for the application.

Optional fans over 600 lbs must be independently supported.

1. Check all electrical connections for tightness and contact.
2. Motor and fan should be wired for clockwise rotation when viewed from the back of the motor.

To reverse rotation, single-phase power supply:  
Follow manufacturer's instructions on the motor's nameplate.

To reverse rotation, three-phase power supply:  
Turn electrical power OFF at source and switch any two leads on the motor junction box.

### **WARNING**

Do not interchange a power lead with the ground wire. Severe damage or personal injury may result.

3. All access panels should be sealed and secure.
4. Check and remove all loose items in or near the inlet and outlet of the unit.
5. Check that all remote controls are properly wired and all service switches are in the OFF position.
6. Check that all optional accessories are installed properly and secured.
7. Turn power ON at source.

8. Turn blower fan motor ON.

### **WARNING**

Do not look into fan outlet to determine rotation. View the fan rotation through the back of the motor.

Check that the exhaust plenum is free of tools or debris before checking blower/fan rotation.

Stand clear of exhaust to avoid personal injury.

9. Adjust airflow with the exhaust damper.

### **NOTICE**

Excess airflow can shorten filter life, cause electrical system failure, and blower motor failure.

## Maintenance Information

Instruct all personnel on safe use and maintenance procedures.



**WARNING** Use proper equipment and adopt all safety precautions needed for servicing equipment. Electrical service or maintenance work must be performed by a qualified electrician and comply with all applicable national and local codes.

Turn power off and lock out electrical power sources before performing service or maintenance work.

Do not install in classified hazardous atmospheres without an enclosure rated for the application.

### Operational Checklist

1. Monitor the physical condition of the collector and repair or replace any damaged components.

Routine inspections will minimize downtime and maintain optimum system performance. This is particularly important on continuous-duty applications.

2. Monitor pressure drop across filters.

Abnormal changes in pressure drop indicate a change in operating conditions and possibly a fault to be corrected. For example, prolonged lack of compressed air will cause an excess build-up of dust on the filters resulting in increased pressure drop. Cleaning off-line with no flow usually restores the filters to normal pressure drop.

3. Monitor exhaust.

### Filter Removal and Installation



**WARNING** Use proper safety and protective equipment when removing contaminants and filters.

Dirty filters may be heavier than they appear.

Use care when removing filters to avoid personal injury.

1. Turn power to unit OFF.
2. Examine the door seal and seal frame, and replace as necessary. Check the door gutters and rubber drain flap for accumulations and obstructions, clean as necessary.
3. Inspect the cabinet interior and remove any foreign material that may have accumulated.

#### Impinger

1. Clean or soak the impinger in mild detergent or solvent, or in severe cases, steam.
2. Re-install with the handle facing you.

#### Pre-Filters

1. Wash or soak the 1-in aluminum pre-filter in mild detergent or solvent. This pre-filter can be washed several times before replacing.

#### **NOTICE**

Do not use high-pressure washing. Filter damage will occur.

2. When replacing, observe the direction-of-flow arrow on the filter frame, and install accordingly.
3. Dispose of filters in accordance with local procedures.

#### 4-in Wire Mesh

1. Soak the filter in an appropriate wash tank. Rinse and dry.
2. Re-install with the handle facing you.

**Box Filter**

1. Remove box filter and dispose of properly.
2. Inspect the pile seal for condition. Replace if torn or damaged.
3. Insert new box filter with the finger loop and airflow direction arrow facing out.
4. Close and secure access door.

**Cabinet Cleaning and Inspection**

1. Inspect cabinet interior.
2. Remove foreign material, wipe interior, and clean the sealing surfaces of the filters, cabinet doors, and door gutters.

**P-Trap Service**

1. Place a suitable container under the p-trap, turn the collector OFF and remove the pipe plug.
2. Allow fluid and particulate to drain.
3. Use thread sealant and replace pipe plug.
4. Refill the p-trap with suitable fluid before restarting the collector.

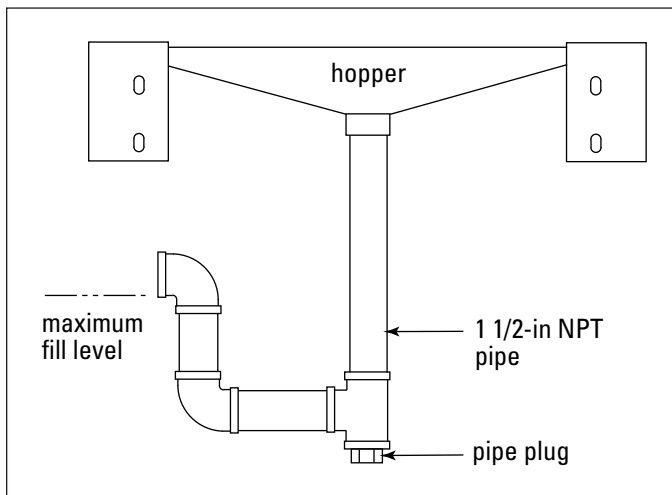

P-Trap Service

**P-Trap with Y Strainer, Screen Cleaning**

1. Place a suitable container under the screen clean-out valve, turn the collector OFF, close the p-trap valve, then open the screen clean-out valve.
2. Allow fluid and particulate to drain.
3. With the clean-out valve open, slowly open the p-trap valve. This allows fluid still trapped in the hopper to drain.

Note: A substantial amount of fluid may be trapped in the hopper and could exceed the container capacity. Open the p-trap valve slowly.

**P-Trap with Y Strainer, Screen Removal**

1. Close the p-trap valve.
2. Unscrew the screen cap and pull the screen out.
3. Clean the screen and the inside of the y-strainer body and re-assemble taking care to seat the screen in the body and cap.
4. Close the clean-out valve.
4. Refill the p-trap with suitable fluid before restarting the collector.

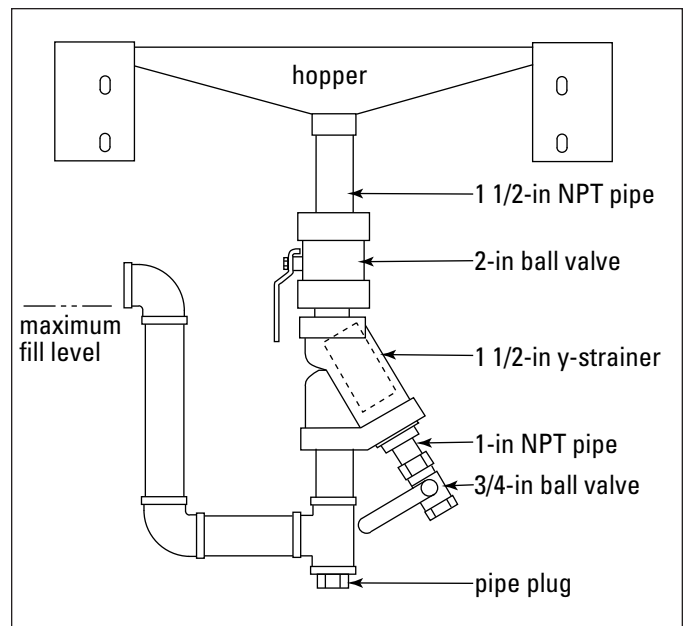

P-Trap with Y-Strainer



## Split Taper™ Bushing Mounting Instructions

Many fans are furnished with split taper bushings for mounting the impeller to the shaft. When properly assembled, the bushings grip the hub with a positive clamping action.

1. Bushel barrel and bore of impeller are tapered to ensure concentric mounting and a true running propeller.
2. Capscrews, when tightened, lock bushing in propeller. Use special plated capscrews and nylock nuts.

Bushing No.	Bolt Size	Torque Ft-Lbs
QT/QH/L/H	1/4-20	7-1/2

3. Bushing is split so that when the locking capscrews force bushing into tapered bore, the bushing grips the shaft with a positive clamping fit. This will withstand vibration and heavy loads without being loosened.
4. Impeller and bushing assembly is keyed to the shaft and held in place by compression, which adds driving strength.

### NOTICE

Before assembly, ensure shaft and keyway are clean and smooth. Check key size with both shaft and bushing keyway.

5. To assemble, insert the capscrews through the clearance holes in the bushing and install bushing loosely into the impeller. Do not press or drive. Start capscrews by hand, turning them just enough to engage threads in the nylock nut. Do not use a wrench at this time. The bushing should be loose enough in the propeller to move freely. Slide impeller and bushing assembly onto shaft, allowing adequate clearance for shaft end play to prevent friction. Fit key into keyway. Do not force impeller and bushing onto shaft. If it does not go on easily, check shaft, bushing, and key sizes once again.

Tighten capscrews gradually and evenly with wrench similar to mounting an automobile wheel. Rotate a quarter turn on each capscrew successively until

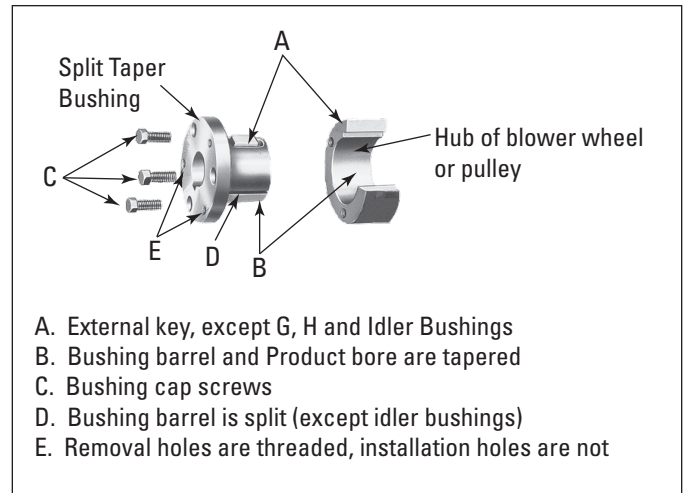

Spilt Taper Bushing Installation

- A. External key, except G, H and Idler Bushings  
 B. Bushing barrel and Product bore are tapered  
 C. Bushing cap screws  
 D. Bushing barrel is split (except idler bushings)  
 E. Removal holes are threaded, installation holes are not

all capscrews are tight. These capscrews force the taper bushing into the hub, which in turn compresses the bushing onto the shaft. This makes a positive clamping fit. The torque must not exceed the value specified in the table.

### CAUTION

Do not attempt to pull bushing flange flush with hub end.

There should be a clearance which varies approximately 3/16-in to 1/4-in with the bushing size when tightened. This is not a locating dimension.

### Impeller Assembly Removal

1. Remove all capscrews from impeller and hub assembly.
2. Insert capscrews into the threaded holes in the bushing flange.
3. Tighten each bolt in quarter of a turn increments to push the impeller off the bushing. This forces the bushing loose from the propeller hub and releases the compression so that the entire assembly will slide from the shaft.
4. Pull the bushing off the shaft.

### NOTICE

If the assembly has been in place sometime it may be necessary to use a wheel puller to remove the bushing. Never use a wheel puller on the impeller.

## Optional Equipment

### Leg Installation, MM 1200 Only

1. Attach the legs to the assembled unit and plenum with the hardware supplied. Do not tighten hardware at this time.
2. Lift into position over the anchor bolts and lower slowly.
3. Fasten each leg pad to the anchor bolts with customer-supplied flat washers, lock washers, and hex nuts. Do not tighten hardware.
4. Level unit. Tighten hardware on all legs and anchor bolts.

### Motor

Optional single phase, 115-Volt, 50 or 60 Hz motors and three phase, 230/460 or 575-Volt, 50 or 60 Hz motors are available.

### Hose Kit

An optional inlet hose kit is available for overhead mounting. The kit includes a 10-ft hose, two hose clamps, and a collar.

### HEPA Filter

The optional HEPA filter, rated at 99.97% at 0.3 microns, is available for generated smoke or ultra-fine mist.

### Ceiling Installation

**Note:** All ceiling supports must be sized to accommodate the entire weight of the unit plus the weight of the collected material and coolant in the hopper.

Install unit to reduce sway or vibration.

1. Use four, ASTM-A36 or greater, 1/4-in threaded rods to suspend the unit. Thread a 1/4-in hex nut onto each rod at least 1 1/2-in.

2. Raise unit into position. Place a flat washer on each rod before placing the rod through the mounting or suspension bracket.
3. Place another flat washer and 1/4-in lock nut on the threaded rod under the mounting or suspension bracket. Allow 1/4-in of threaded rod to protrude through each nut.
4. Level unit in all directions by tightening the bottom lock nut.
5. When unit is level, lower the top nut to the top washer and bracket. Hold the bottom lock nut and tighten the top nut securely.

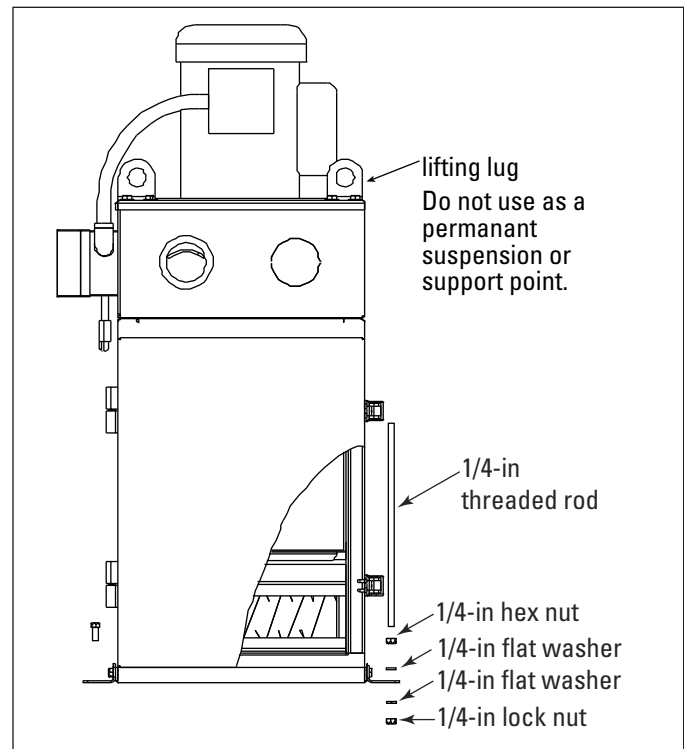

Ceiling Mount Installation

**Wall-Mount Brackets, MM 1200 only**

- 1. Attach the right and left brackets to the unit using the shipping or eyebolt holes.
- 2. Secure with 1/4-20 x 3/4-in bolts, flat washers, lock washers, and hex nuts.
- 3. Lift the unit to the desired location and mark the drill locations using the bracket holes as a guide.
- 4. Drill holes and secure unit to wall using the hardware supplied.

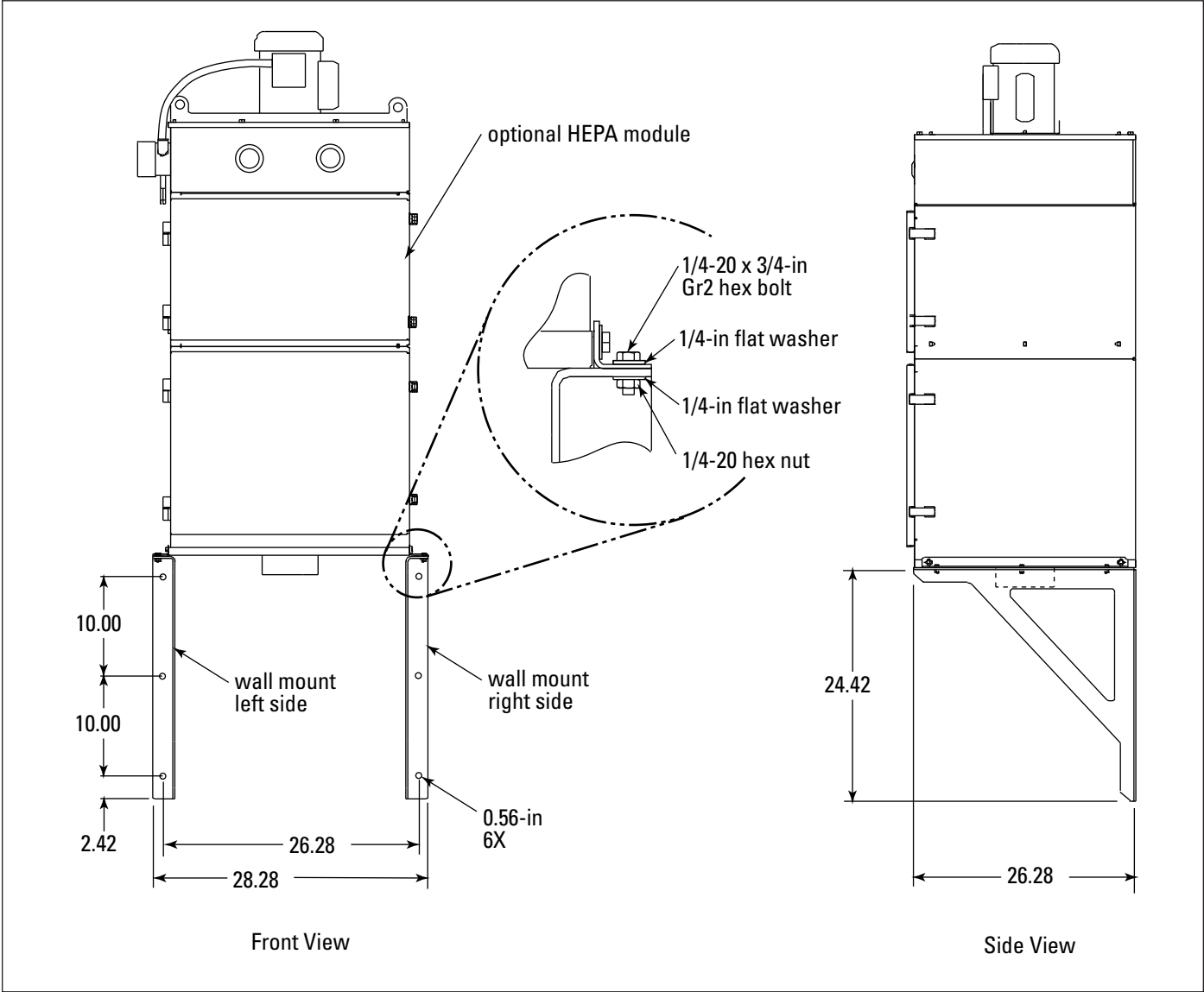

MM 1200 Wall Mount

## Troubleshooting

Problem	Probable Cause	Remedy
<b>Blower fan and motor do not start</b>	Improper motor wire size	Rewire using the correct wire gauge as specified by national and local codes.
	Not wired correctly	Check and correct motor wiring for supply voltage. See motor manufacturer's wiring diagram. Follow wiring diagram and the National Electric Code.
	Unit not wired for available voltage	Correct wiring for proper supply voltage.
	Input circuit down Switches not ON	Check power supply to motor circuit on all leads. Turn service switches ON. Press the reset button on the motor starter.
<b>Blower fan and motor start, but do not stay running</b>	Incorrect motor starter installed	Check for proper motor starter and replace if necessary.
	Access doors are open or not closed tight	Close and tighten access doors. See Filter Replacement.
<b>Blower fan and motor start with a whine and does not reach full speed</b>	Motor single-phasing	Stop motor immediately. Check fuses and wiring for interruptions.
<b>Motor makes scraping or knocking noise</b>	Motor cooling fan cover shifted	Check that the motor cooling fan and cover are in place and secured.
<b>No or low suction pressure</b>	Blower fan damper control not adjusted properly	Check airflow in duct. Adjust damper control until proper airflow is achieved and the blower motor's amp draw is within the manufacturer's rated amps.
	Electrical circuit overload	Check that the power supply circuit has sufficient power to run all equipment.
	Duct is plugged Filters plugged	Check for and remove obstructions from the duct. Check and clean or replace dirty or plugged filters. See Filter Removal and Installation.
	Fan rotation backwards	See Electrical Installation.
<b>Excess vibration</b>	Not installed correctly	Check structural supports. Tighten all bolts on legs and cross braces.
<b>Clean-air outlet discharging dust</b>	Filters not installed correctly	See Filter Replacement.
	Vee-bag torn	Replace as necessary
	HEPA damaged	Check clamping handle on HEPA filter. Tighten if necessary.
	Door or door seals damaged	Check all doors and door seals. Replace as necessary.







## The Donaldson Torit Warranty

Donaldson warrants to the original purchaser that the major structural components of the goods will be free from defects in materials and workmanship for ten (10) years from the date of shipment, if properly installed, maintained and operated under normal conditions. Donaldson warrants all other Donaldson built components and accessories including Donaldson Airlocks, TBI Fans, TRB Fans, Fume Collector products, Donaldson built electrical control components and Donaldson built Afterfilter housings for twelve (12) months from date of shipment. Donaldson warrants Donaldson built filter elements to be free from defects in materials and workmanship for eighteen (18) months from date of shipment. Donaldson does not warrant against damages due to corrosion, abrasion, normal wear and tear, product modification, or product misapplication. Donaldson also makes no warranty whatsoever as to any goods manufactured or supplied by others including electric motors, fans and control components. After Donaldson has been given adequate opportunity to remedy any defects in material or workmanship, Donaldson retains the sole option to accept return of the goods, with freight paid by the purchaser, and to refund the purchase price for the goods after confirming the goods are returned undamaged and in usable condition. Such a refund will be in the full extent of Donaldson's liability. Donaldson shall not be liable for any other costs, expenses or damages whether direct, indirect, special, incidental, consequential or otherwise. The terms of this warranty may be modified only by a special warranty document signed by a Director, General Manager or Vice President of Donaldson. Failure to use genuine Donaldson replacement parts may void this warranty. THERE EXIST NO OTHER REPRESENTATIONS, WARRANTIES OR GUARANTEES EXCEPT AS STATED IN THIS PARAGRAPH AND ALL OTHER WARRANTIES INCLUDING MERCHANTABILITY AND FITNESS FOR A PARTICULAR PURPOSE, WHETHER EXPRESS OR IMPLIED ARE HEREBY EXPRESSLY EXCLUDED AND DISCLAIMED.

[astgroup.ca](http://astgroup.ca)



905-821-8860



**Donaldson.**  
FILTRATION SOLUTIONS