

Donaldson.  
Torit®

## Live Bottom Hopper

AN, FT and Meyer (Standard and NFPA Rated)

## Installation and Operation Manual

Installation, Operation and Service Manual

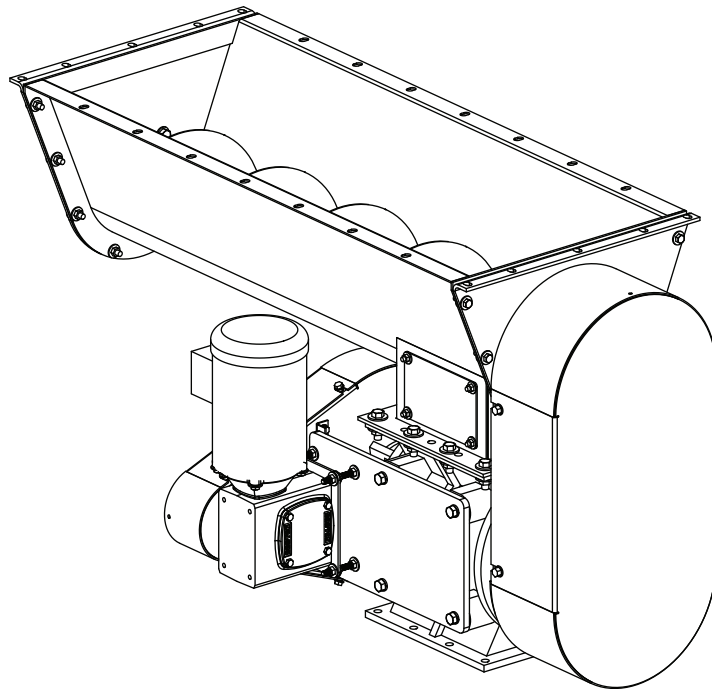

This manual contains specific precautions related to worker safety. The hazard alert image denotes safety related instructions and warnings in this manual. DO NOT install, operate, or perform maintenance on this collector until you have read and understood the instructions, precautions and warnings contained within this manual.

English  
Master Language

IOM AG8262501 (ENG)  
Revision 1

## IMPORTANT NOTES

This manual has been supplied to assist with the installation, operation and maintenance for the collector purchased. Please read the manual before installing, operating, or performing maintenance on the collector as it contains specific precautions for worker safety. It is the owner's responsibility to ensure that this manual is available for use by installers, operators and maintenance personnel that will be working with this collector. This manual is the property of the owner and should be left with the collector when installation has been completed. **DO NOT** operate this collector until you have read and understood the instructions and warnings located in this manual.

For additional copies of this manual, contact Donaldson Torit.



The Safety Alert Symbol indicates a hazardous situation which, if not avoided could result in death or serious injury. Obey all safety messages following this symbol to avoid possible injury or death. The possible hazards are explained in the associated text messages.

### **NOTICE**

NOTICE indicates a potential situation or practice which is not expected to result in personal injury, but which if not avoided, may result in damage to equipment.

**Contents**

- IMPORTANT NOTES ..... i
- 1 Safety Communication ..... 1
- 2 Product Description ..... 3
  - Options and Accessories ..... 3
- 3 Operation ..... 5
- 4 Product Service ..... 6
  - Drive Components and Lubrication, All Models ..... 7
  - Wiper Seal Replacement and Auger Maintenance ..... 7
  - Troubleshooting ..... 8
- Appendix A - Installation ..... 10
  - Installation ..... 11
  - Electrical Wiring ..... 12
  - Reducer ..... 12
  - Start-up / Commissioning ..... 14
  - Decommissioning ..... 15
  - Product Information ..... 16
  - Service Notes ..... 17
- Donaldson Industrial Air Filtration Warranty ..... 20

1

## Safety Communication



Improper operation of dust collectors and/or dust control systems may contribute to conditions in a work area or facility which could result in severe personal injury, and product or property damage. All dust collection equipment should be used only for its intended purpose and should be properly selected and sized for its intended use.

Process owners have important responsibilities relating to identifying and addressing potential hazards in their processes. When the potential for handling combustible dust exists within a process the process owner should include combustion hazards in their risk management activities and should comply with applicable codes and standards related to combustible dust.

Electrical installation must be performed by a qualified electrician.

This equipment is not designed to support site ducts, piping, or electrical services. All ducts, piping, or electrical services must be adequately supported to prevent injury and/or property damage.

Site selection must account for wind, seismic zone, and other load conditions.

Equipment may reach peak sound pressure levels above 80 dB (A). Noise levels should be considered when selecting collector location.

Most dusts present safety and health hazards that require precautions. Wear eye, respiratory, head and other protection equipment suitable for the type of dust.

Some components may be heavier than they appear. Use appropriate lifting methods to avoid personal injury and/or property damage.

Rotating blades can cause serious injury. Operate equipment only when all guards are correctly and securely in place.

Turn all power off and lock out all power before performing service or maintenance work. It is not unusual for the equipment to be operated from a remote location, so equipment may start or stop unexpectedly.

The hopper/auger inlet and the rotary valve outlet of the live bottom hopper should be attached to an enclosure or have a guard in place to prevent hands, feet, or loose clothing from entering the live bottom hopper.

### **NOTICE**

Optional discharge devices may require independent support. Discharge devices over 800 lbs. must be independently supported.

Hopper discharge devices must be sized to handle anticipated dust volumes. Dust may discharge infrequently as cleaning dislodges accumulated dust at above average levels and the valves should be sized to accommodate these conditions.

## Combustible Dust Hazards

Among other considerations, the current NFPA standards require owners whose processes involve potentially combustible materials to have a current Dust Hazard Analysis, which can serve as the foundation for their process hazard mitigation strategy. Mitigation may include but is not limited to:

- Prevention of all ignition sources from entering any dust collection equipment.
- Selection and implementation of fire and explosion mitigation, suppression, and isolation strategies appropriate for the risks in their process.
- Development and use of work practices to maintain safe operating conditions, and to ensure combustible dust does not accumulate within their plant or process equipment.

Donaldson designs, manufactures, and sells industrial air filtration products for a wide variety of applications. Some applications may include processes or materials with inherent fire and explosion hazards. Donaldson is neither an expert nor a certified consultant in fire, spark, or explosion detection, suppression, or control. Donaldson does not provide engineering consulting services related to process or dust hazard analyses, or code and standard compliance. Complying with applicable codes and standards and managing the risks associated with the process or materials remains the responsibility of the process owner/operator. Donaldson may provide referrals to consultants, suppliers of equipment or services related to the detection and/or mitigation of sparks, fires and/or explosions, but Donaldson does not assume responsibility for any such referrals, nor does Donaldson assume any liability for the fitness of a mitigation strategy or product for a particular installation or application. The process owner's final selection of dust collectors and risk mitigation strategies should be based on the outcome of a Dust Hazard / Process Hazard Analysis performed by the process owner. Although early engagement of a dust collector supplier provides helpful insights on the availability and features of various products, process owners should consult with a combustible dust expert and/or a process safety expert before making actual product and mitigation strategy selections.

Donaldson recommends that all industrial air filtration system designs be reviewed and approved by an expert consultant who is responsible for the integrity of the system design and compliance with applicable codes and standards. It is the process owner's responsibility to understand the risks in their process and mitigate those risks in accordance with all applicable laws, regulations and standards, including those published by the NFPA. Donaldson also recommends that proper maintenance and housekeeping procedures and work practices be evaluated, developed, and followed to maintain any industrial air filtration products in safe operating condition.

Many factors beyond the control of Donaldson can affect the use and performance of Donaldson products in a particular application, including the conditions under which the product is used. Since these factors are uniquely within the user's knowledge and control, it is essential the user evaluate the Donaldson products to determine whether the product is fit for the particular purpose and suitable for the user's application. All products, product specifications, and data (airflow, capacity, dimensions, or availability) are subject to change without notice, and may vary by region or country.

## 2 Product Description

The Live Bottom Hopper (LBH) is used as an auger/airlock/feeder device on conveying systems and dust collection equipment. It allows continuous evacuation of particulate from a dust collector, while providing an effective seal.

The hopper contains a 9 inch diameter right hand auger designed to move accumulated dust to the end of the trough where the rotary airlock is located. Standard inlet and outlet sizes range from 10 to 12 inch square to square configurations.

Per NFPA 69-121.2.4.3.8, the NFPA rated Meyer Live Bottom Hopper must be coupled with an independent explosion detection device which will turn off the live bottom hopper in the event of an explosion. This device is not supplied with the NFPA rated Meyer Live Bottom Hopper.

### AN Live Bottom Hopper

The AN airlock is a six blade valve with standard neoprene flexible tips designed for most nuisance dust discharge requirements. The double wiper action creates an effective seal and handles differential pressure up to 17" wg. Standard options, based on the type of dust removed, include flex tips of EPDM and polyurethane.

### FT Live Bottom Hopper

The FT airlock is a six blade valve with standard urethane flexible tips designed for most nuisance dust discharge requirements. The double wiper action creates an effective seal and handles minimal differential pressures.

### Meyer Live Bottom Hopper

The standard and NFPA Meyer airlock has a steel housing with a 6 or 8 vane mild steel beveled blade rotor which can handle differential pressures up to 22 psi.

## Intended Use

The AN, FT and Meyer LBH are designed for use in wood and metal working, grain handling, and dry powder processing application. The AN and FT LBH are recommended for applications with differential pressures across the AN or FT valve up to 17"wg and the Meyer LBH is recommended for applications with differential pressures across the Meyer valve up to 22 psi.

## Options and Accessories

### Hopper

- 48 inch trough/auger
- 72 inch trough/auger

### Valves

- 10 x 10
- 12 x 12

### Rotor Blades

- AN - EPDM, polyurethane, white neoprene and black neoprene
- FT - 6 vane urethane flexible tips
- Meyer - 6 or 8 vane mild steel beveled blades

AN and FT Rotor CW Rotation  
Wiper blades bent opposite rotation

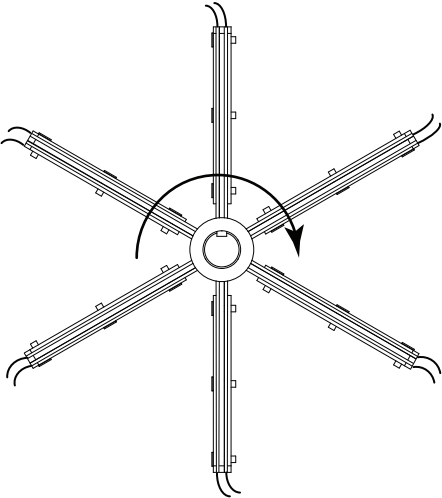

AN and FT Rotor CCW Rotation  
Wiper blade bent opposite rotation

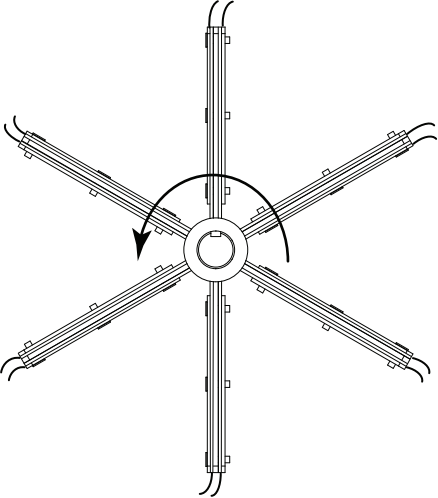

Meyer Rotor Right Beveled Blade CW Rotation

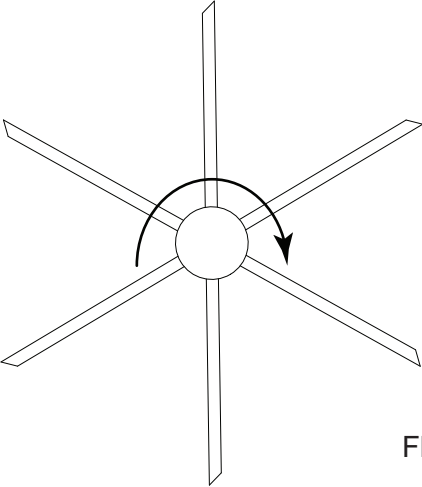

Meyer Rotor Left Beveled Blade CCW Rotation

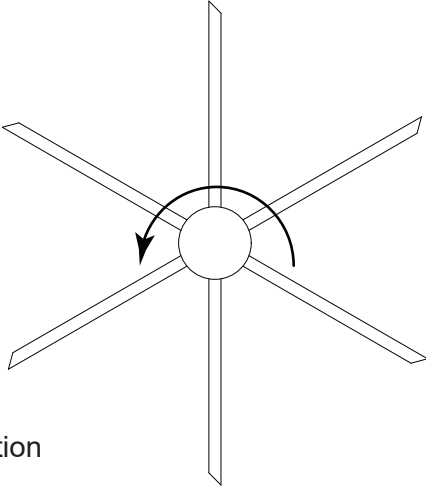

Flat Blade CW or CCW Rotation

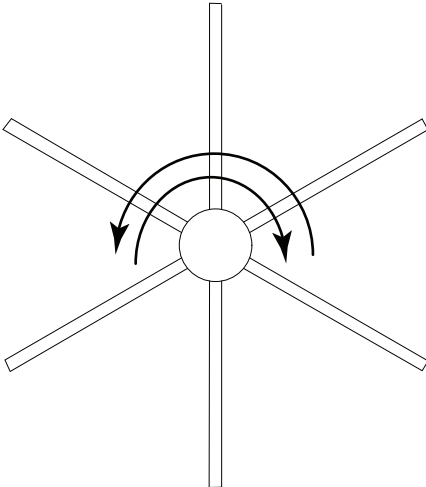

### 3 Operation



Electrical work during installation, service or maintenance must be performed by a qualified electrician and comply with all applicable national and local codes.

Turn all power off and lock out all power before performing service or maintenance work.

Check that the collector is clear and free of all debris before starting.

Do not install in classified hazardous atmospheres without an enclosure rated for the application.

The Live Bottom Hopper is used as an auger/airlock/feeder device in dust control applications. When used as an airlock, an effective seal between the valve's inlet and outlet is maintained while allowing dust or material to pass through.

During normal operation, the FT and Meyer auger and valve rotor typically rotates at 15 rpm and the AN valve rotor rotates at 22 rpm. The auger conveys product or dust through the trough to the rotating valve inlet and falls into each rotor pocket as it rotates. The material is discharged by gravity as each rotor pocket passes the outlet flange.

When used as a metering device, the valve allows a specific amount of material to pass per revolution, depending on the size and speed of the valve.

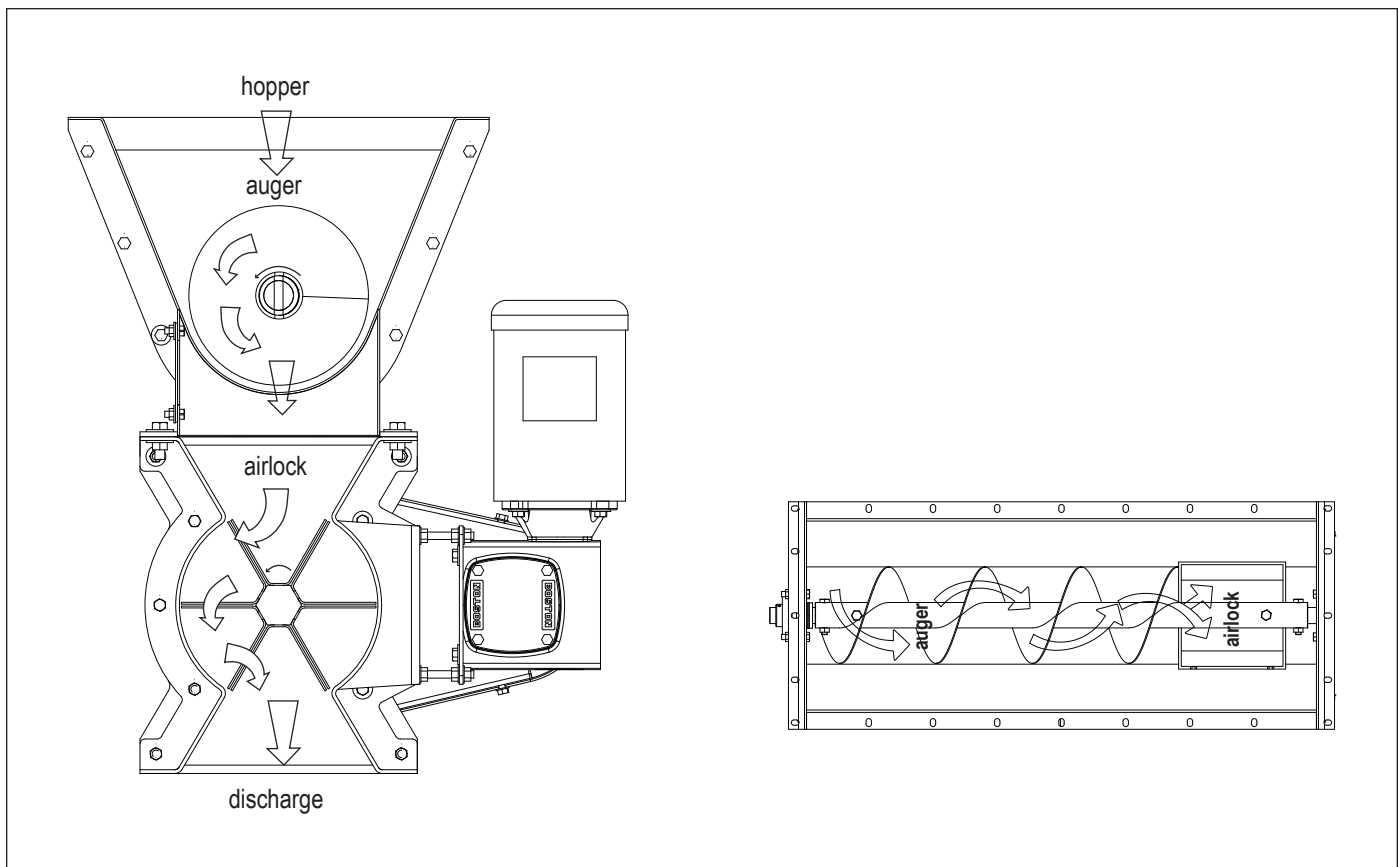

Live Bottom Hopper Operation



## 4

**Product Service**

During service activities there is some potential for exposure to the dust in the collector. Most dusts present safety and health hazards that require precautions. Wear eye, respiratory, head and other protection equipment suitable for the type of dust when performing any service activities.

LOCK-OUT all energy sources prior to performing any service or maintenance on the equipment.

Electrical service or maintenance work must be performed by a qualified electrician and comply with all applicable national and local codes.

Rotating blades can cause serious injury. Operate equipment only when all guards are correctly and securely in place.

The hopper/auger inlet and rotary valve outlet of the live bottom hopper should be attached to an enclosure or have a guard in place to prevent hands, feet, or loose clothing from entering the live bottom hopper.

Turn all power off and lock out all power before performing service or maintenance work. It is not unusual for the equipment to be operated from a remote location, so equipment may start or stop unexpectedly.

**Operational Checklist**

1. Monitor the physical condition of the collector and repair or replace any damaged components.

Routine inspections will minimize downtime and maintain optimum system performance. This is particularly important on continuous-duty applications.

2. Monitor pressure drop across filters.

Abnormal changes in pressure drop may indicate a change in operating conditions and possibly a fault to be corrected. For example, prolonged lack of compressed air will cause an excess build-up of dust on the filters resulting in increased pressure drop. Cleaning off-line with no airflow usually restores the filters to normal pressure drop.

3. Monitor exhaust.
4. Monitor dust disposal.

## Drive Components and Lubrication, All Models

1. Periodically check drive components for proper operation. Follow the motor and reducer manufacturers' instructions for maintenance.
2. Check gear reducer oil level and replace at regular intervals.
3. Check the valve and auger drive chain for proper alignment and tension, and adjusted as needed.
4. Lubricate the valve and auger chains at least once a month and flanged bearings once every other month with a high grade, lithium-base grease for applications under 175° F. For higher temperature or corrosive vapor applications, consult your sales representative to obtain specific lubrication instructions.

## Wiper Seal Replacement and Auger Maintenance

1. When practical, remove the live bottom hopper from the equipment and place on a workbench for disassembly.
2. Remove the live bottom hopper chain guards, chains, and sprockets.
3. Loosen setscrews and remove collars on flanged bearings.
4. Unscrew fasteners and remove valve and auger end plates opposite the drive ends.
5. Remove auger from trough and wipe clean with a dry clean towel.
6. Inspect auger and trough for damage and replace if needed.
7. Remove valve rotor assembly.
8. Unscrew fasteners and remove wiper backup plates from each rotor pocket.
9. Remove rotor wipers and shaft seals.
10. Install new wipers and shaft seals.
11. Reassemble live bottom hopper in reverse order and replace the sprockets, chains, and chain guards.

**NOTICE**

Check that the rotor assembly is centered in the valve housing.

12. Place new 1/4-in diameter sealer on the live bottom hopper top flange. Reinstall live bottom hopper to the equipment.

## Troubleshooting

Problem	Probable Cause	Remedy
<b>Valve rotor does not turn freely, binds, or chatters</b>	Rotor not centered in valve housing	Center rotor.
	Particulate or foreign object caught between rotor and housing	Reverse rotor to remove object. If this does not work, remove valve from service and disassemble.
	Too much particulate feed to valve inlet	Reduce feed rate or use larger valve size.
	Excessive particulate caking on valve housing	Remove excessive moisture or use rotor with beveled blades and two cutter blades and/or coated valve housing.
	AN or FT wiper blade not bent in correct direction.	Check AN or FT wiper blade is bent in correct direction. Wiper blades should be bent in the opposite direction of rotar rotation.
	Meyer rotor with machine blades may be turning in the wrong direction (for beveled blades)	Reverse valve rotation.
<b>Excessive particulate caking on valve housing</b>	Excessive moisture in product.	Remove excessive moisture from upstream particulate or use rotor with beveled blades and two cutter blades and/or coated valve housing.
	Rotor may be turning in the wrong direction (for beveled blades)	Reverse valve rotation.
<b>Motor stops running</b>	Improper fuse or breaker size	Check fuse or breaker size required based on motor FLA rating.
	Motor improperly wired (or for wrong voltage)	Check motor wiring per diagram on motor nameplate.
	Wrong voltage supplied to motor	Check motor nameplate.
	Safety interlock activated	Check control panel wiring to motor.
	See probable causes above for valve rotor does not turn freely, binds, or chatters	See remedies above for valve rotor does not turn freely, binds, or chatters.
<b>Motor runs but valve not turning</b>	Reducer problem	Check reducer operation.
	Broken or misaligned drive chain, sprocket, or shaft key	Inspect drive components and adjust or repair.
<b>Particulate bridges above valve inlet</b>	Particulate not free flowing	May need steeper inlet hopper or anti-bridging devices like bin flow areators or vibrator.
	Light particulate and/or high pressure differential across valve rotor	Connect the valve housing air vent to a surge hopper above valve or a dust control suction line.
	Excessive rotor/housing clearances	Install new rotor with tighter tolerances (reduced clearance).

## Troubleshooting

Problem	Probable Cause	Remedy
<b>Valve endplates or housing are hot</b>	Rotor not centered in valve housing	Center rotor.
	Particulate or foreign object caught between rotor and housing	Reverse rotor to remove object. If this does not work, remove valve from service and disassemble.
	Too much particulate feed to valve inlet	Reduce feed rate or use larger valve size.
	Excessive particulate caking on valve housing	Remove excessive moisture or use rotor with beveled blades and two cutter blades and/or coated valve housing.
	AN or FT wiper blade not bent in correct direction.	Check AN or FT wiper blade is bent in correct direction. Wiper blades should be bent in the opposite direction of rotar rotation.
	Meyer rotor with machine blades may be turning in the wrong direction (for beveled blades)	Reverse valve rotation.
<b>Dust leaks outside valve</b>	Bad bearings	Replace or lube bearings.
	Loose inlet/outlet or end plate flange connections	Tighten as required.
	Packing glands loose or worn	Tighten or replace packing glands.

# **Appendix A - Installation**

## Installation



Electrical Installation (including bonding and grounding of the collector) must be performed by a qualified electrician.

This equipment is not designed to support site ducts, piping, or electrical services. All ducts, piping, or electrical services must be adequately supported to prevent injury and/or property damage.

Do not install in classified hazardous atmospheres without an enclosure rated for the application.

Service must be performed by trained and qualified maintenance personnel.

Turn all power off and lock out all power before performing service or maintenance work. It is not unusual for the equipment to be operated from a remote location, so equipment may start or stop unexpectedly.

Equipment may reach peak sound pressure levels above 80 dB (A). Noise levels should be considered when selecting equipment location.

Rotating blades can cause serious injury. Operate equipment only when all guards are correctly and securely in place.

## Delivery and Inspection

Upon arrival inspect equipment and report any damage to delivery carrier. File any damage claims with the delivery carrier. Request a written inspection report from the Claims Inspector to substantiate all damage claims.

Compare the equipment received with the description of product ordered. Report any incomplete shipments to the delivery carrier and your Donaldson Torit representative.

## Unloading and Positioning



Equipment should be lifted only by qualified crane or fork truck operators.

Failure to lift the equipment correctly can result in severe personal injury and/or property damage.

1. Remove any crates or shipping straps.
2. Lift the packaged collector from transport container.
3. Inspect for any damage and/or missing parts and report to freight carrier.
4. Check for any hardware which may have become loose during shipment and tighten as necessary.

## Lifting Information



Failure to lift the equipment or sub-assemblies correctly can result in severe personal injury and/or property damage.

Only qualified crane or forklift operators should be allowed to lift equipment.

1. Use all lifting points provided.
2. Use clevis connectors, not hooks, on lifting slings.
3. Use spreader bars to prevent damage to equipment.
4. Check the Specification Control drawing for weight and dimensions of the components to ensure adequate crane capacity.
5. Use drift pins to align holes in section flanges during assembly.

## Electrical Wiring



Electrical installation, service, or maintenance work must be performed by a qualified electrician and comply with all applicable national and local codes.

Turn all power off and lock out all power before performing service or maintenance work. It is not unusual for the equipment to be operated from a remote location so equipment may start or stop unexpectedly.

Do not install in classified hazardous atmospheres without an enclosure rated for the application.

1. Remove the protective plastic wrap, hardboard inlet cover, and flange gaskets shipped inside the live bottom hopper.
2. Inspect the auger and valve pockets for foreign material.
3. Determine the proper position required for the live bottom hopper. Allow clearance for electrical connections and future maintenance.

### **NOTICE**

Companion flanges must be true and square to live bottom hopper flanges and of sufficient size to support live bottom hopper weight. Otherwise additional support will be required.

4. Place 1/4-in diameter sealer on the live bottom hopper top flange.
5. Fasten the live bottom hopper trough to the dust collector's hopper flange using 3/8-16 bolts and washers. Tighten hardware alternately in steps. Avoid over tightening.
6. Install a discharge spout or guard to the rotary valve outlet flange using 3/8-16 bolts and washers. Tighten hardware alternately in steps. Avoid over tightening.

## Reducer

### **NOTICE**

Check reducer oil level before operating the valve.

1. Fill the reducer to the level indicated with oil of the proper viscosity. Refer to the reducer installation lubrication and operation instructions provided with the valve for oil viscosity and oil change recommendations. In the absence of this information, use Mobil® SHC 634 synthetic lubricant for operating ambient temperature range of -30° C to 125° F.
2. Check that vent caps, drain, and fill plugs are installed and secure.

### **NOTICE**

Consult the petroleum supplier for lubricants that are acceptable to the Food and Drug Administration and other regulating agencies when installing in food and drug industries, including animal foods.

Standard motors are wired for 230/460-Volt, 3 phase, 60 Hz operation.

1. Install a customer-supplied motor starter with a low voltage control circuit for the motor.
2. Using the wiring diagram supplied, wire the motor and motor starter. Use appropriate wire gauge for the rated amp load as specified by local codes.



Do not interchange a power lead with the ground wire. Severe personal injury and/or property damage may result.

3. Turn the motor ON then OFF to check for proper rotation by referencing the rotation arrow located on the live bottom hopper.

To reverse rotation, three-phase power supply:

Turn electrical power OFF at source and switch any two leads on the output-side of the motor starter.

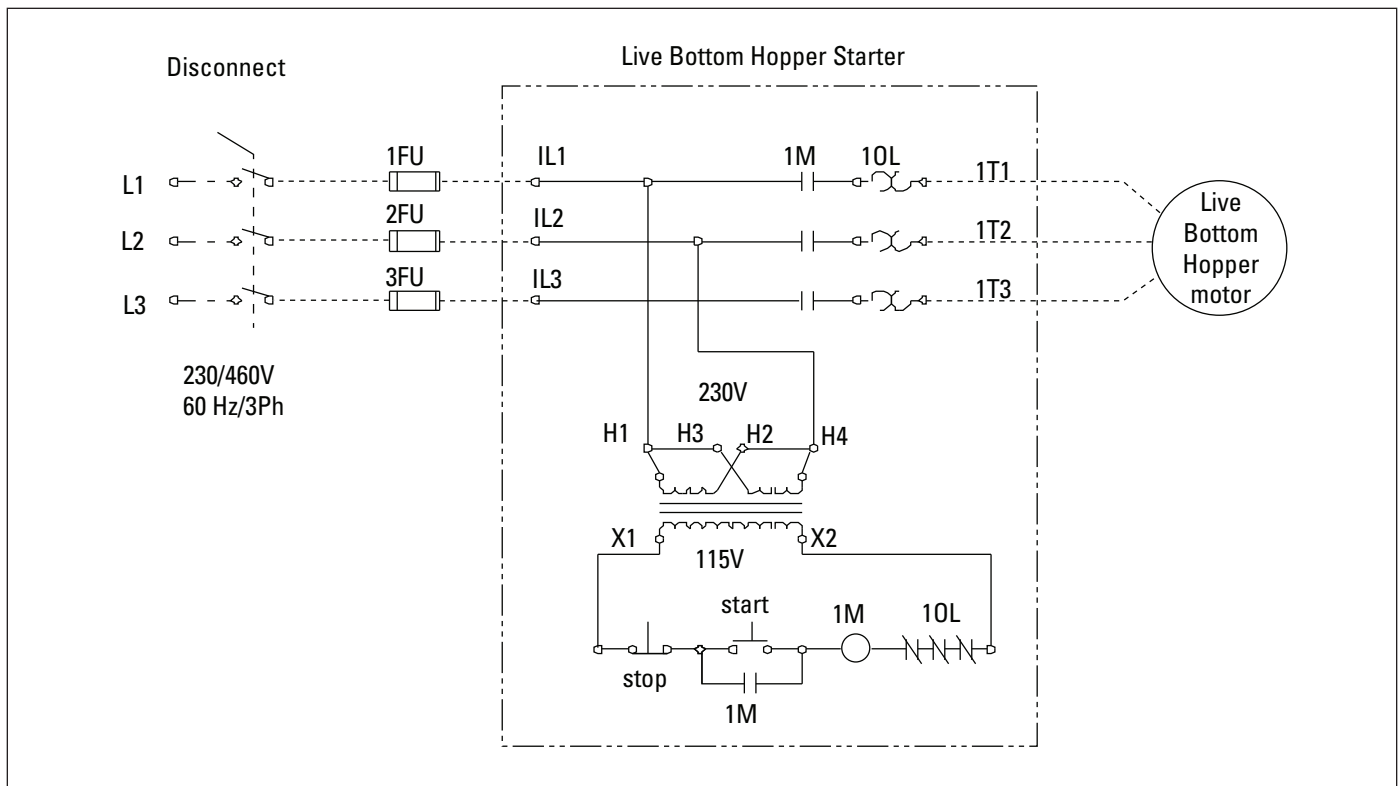

Live Bottom Hopper Typical Wiring Diagram



## Start-up / Commissioning

Instruct all personnel on safe use and maintenance procedures.



Rotating blades can cause serious injury. Operate equipment only when all guards are correctly and securely in place.

The hopper/auger inlet and the rotary valve outlet of the live bottom hopper should be attached to an enclosure or have a guard in place to prevent hands, feet, or loose clothing from entering the live bottom hopper.

Electrical installation, service, or maintenance work must be performed by a qualified electrician and comply with all applicable national and local codes.

Turn all power OFF and lock out all power before performing service or maintenance work. It is not unusual for the equipment to be operated from a remote location so equipment may start or stop unexpectedly.

Do not operate in classified hazardous atmospheres without an enclosure rated for the application.

1. Check all electrical connections for tightness and contact.
2. Turn the live bottom hopper motor ON then OFF to check for proper rotation by referencing the rotation arrow located on the valve endplate.



Rotating blades and auger can cause serious injury.

Keep hands, feet and loose clothing away from both inlet and outlet openings to avoid injury or damage when valve is operating.

To reverse rotation, three-phase power supply: Turn electrical power OFF at source and switch any two leads on the output-side of the live bottom hopper motor starter.



Do not interchange a power lead with the ground wire. Severe personal injury and/or equipment damage may result.

3. Check for and remove all loose items in or near the inlet and outlet of the unit.
4. Check that all remote controls are wired into the control system, and all service switches are in the OFF position.
5. Check that all optional accessories are installed properly and secured.
6. Check the oil level in the reducer and that the vent plugs are in place and secure.
7. Check that the drive guard is in place and secure.
8. Turn power (service switch) ON at source.
9. Check that live bottom hopper operation does not disrupt upstream or downstream equipment.
10. Operate live bottom hopper for 10 to 15 minutes and inspect housing for hot spots or unusual noises.
11. Turn upstream equipment ON to run product through the live bottom hopper. Continue to inspect housing for hot spots or noises.

### **NOTICE**

If the live bottom hopper discharges into a conveying system, the conveying system should also be operating to prevent overfilling the conveying system.

12. Check motor amp draw to verify that live bottom hopper is not being overloaded.
13. Check product flow-rate if live bottom hopper is used as a metering device.

## Decommissioning

Once the component has reached the end of operational life it will need to be decommissioned.



During decommissioning, there is potential for exposure to the dust in the collector. Most dusts present safety and health hazards that require precautions. Wear eye, respiratory, head, and other protection equipment suitable for the type of dust when performing any decommissioning activities.

LOCK-OUT all energy sources prior to performing any decommissioning activities on the equipment.

Electrical service must be performed by a qualified electrician.

Disconnection of ducts must be performed by a qualified contractor.

1. Follow the typical shut-down sequence steps located in the operation section to remove as much contaminant from collector as possible.
2. Lock-Out all energy sources to the component, material handling system and other associated equipment.
3. Disconnect electrical power from the material handling system components and remove any associated conduit or from the exterior of the collector.
4. Dispose of the component in a manner suitable for any dust in the component was exposed to and in accordance with all local codes and regulations.

**Product Information** (Process Owner to complete and retain for your records)

Model Number _____	Serial Number _____
Ship Date _____	Installation Date _____
Filter Type _____	
Collected Dust _____	
Dust Properties: Kst _____	Pmax _____ MIE _____ MEC _____
Accessories _____	
Other _____	
_____	







## Donaldson Industrial Air Filtration Warranty

Donaldson warrants to the original purchaser only that the Goods will be free from defects in material and manufacture for the applicable time periods stated below: (1) Major structural components for a period of ten (10) years from the date of shipment; (2) Non-Structural, Donaldson-built components and accessories including Donaldson Airlocks, TBI Fans, TRB Fans, Fume Collector products, Donaldson built electrical control components, and Donaldson-built Afterfilter housings for a period of twelve (12) months from date of shipment; and (3) Donaldson-built filter elements for a period of eighteen (18) months from date of shipment.

Buyer is solely responsible for determining if goods fit Buyer's particular purpose and are suitable for Buyer's process and application. Seller's statements, engineering and technical information, and recommendations are provided for the Buyer's convenience and the accuracy or completeness thereof is not warranted. If, after Seller receives written notice, within the warranty period, that any goods allegedly do not meet Seller's warranty, and Seller, in its sole discretion, determines that such claim is valid, Seller's sole obligation and Buyer's exclusive remedy for breach of the foregoing warranty or any Seller published warranty, will be, at Seller's option, either: (i) repair or replacement of such goods or (ii) credit or refund to Buyer for the purchase price from Seller. In the case of repair or replacement, Seller will be responsible for the cost of shipping the parts but not for labor to remove, repair, replace or reinstall the allegedly defective goods. Refurbished goods may be used to repair or replace the goods and the warranty on such repaired or replaced goods shall be the balance of the warranty remaining on the goods which were repaired or replaced. Any repair or rework made by anyone other than Seller is not permitted without prior written authorization by Seller, and voids the warranty set forth herein. Seller warrants to Buyer that it will perform services in accordance with the Sales Documents using personnel of required skill, experience and qualifications and in a professional and workmanlike manner in accordance with generally recognized industry standards for similar services. With respect to any services subject to a claim under the warranty set forth above, Seller shall, in its sole discretion, (i) repair or re-perform the applicable services or (ii) credit or refund the price of such services at the pro rata contract rate and such shall be Seller's sole obligation and the exclusive remedy for breach of the foregoing warranty on services. Products manufactured by a third party ("Third Party Product") may constitute, contain, be contained in, incorporated into, attached to or packaged together with, the goods. Buyer agrees that: (a) Third Party Products are excluded from Seller's warranty in this Section 7 and carry only the warranty extended by the original manufacturer, and (b) Seller's liability in all cases is limited to goods of Seller's design and manufacture only. EXCEPT FOR SELLER'S WARRANTY OF TITLE TO THE GOODS, SELLER EXPRESSLY DISCLAIMS AND EXCLUDES ALL OTHER WARRANTIES WHATSOEVER, WHETHER, EXPRESSED OR IMPLIED, ORAL, STATUTORY, OR OTHERWISE, INCLUDING BUT NOT LIMITED TO MERCHANTABILITY, FITNESS FOR A PARTICULAR PURPOSE, NON-INFRINGEMENT OF THIRD PARTY INTELLECTUAL PROPERTY AND ANY WARRANTIES ARISING FROM TECHNICAL ADVICE OR RECOMMENDATIONS, COURSE OF DEALING OR OF PERFORMANCE, CUSTOM OR USAGE OF TRADE. Seller's obligations do not cover normal wear and tear or deterioration, defects in or damage to any goods resulting from improper installation, accident or any utilization, maintenance, repair or modification of the goods, or any use that is inconsistent with Seller's instructions as to the storage, installation, commissioning or use of the goods or the designed capabilities of the goods or that, in its sole judgment, the performance or reliability thereof is adversely affected thereby, or which is subjected to abuse, mishandling, misuse or neglect or any damage caused by connections, interfacing or use in unforeseen or unintended environments or any other cause not the sole fault of Seller, and shall be at Buyer's expense. Seller's warranty is contingent upon the accuracy of all information provided by Buyer. Any changes to or inaccuracies in any information or data provided by Buyer voids this warranty. Seller does not warrant that the operation of the goods will be uninterrupted or error-free, that the functions of the goods will meet Buyer's or its customer's requirements unless specifically agreed to, or that the goods will operate in combination with other products selected by Buyer or Buyer's customer for its use.

The terms of this warranty may only be modified by a special warranty document signed by a Director, General Manager or Vice President of Donaldson. To ensure proper operational performance of your equipment, use only genuine Donaldson replacement parts.

**This Product is provided subject to and conditioned upon Donaldson's Terms of Sale ("Terms"), a current copy of which is located at [termsofsale.donaldson.com](http://termsofsale.donaldson.com). These Terms are incorporated herein by reference. By purchasing or using this Product, the user accepts these Terms. The Terms are available on our website or by calling our customer service line at 1-800-365-1331.**

Significantly improve the performance of your collector with genuine Donaldson Torit replacement filters and parts.

**Important Notice:** Many factors beyond the control of Donaldson can affect the use and performance of Donaldson products in a particular application, including the conditions under which the product is used. Since these factors are uniquely within the user's knowledge and control, it is essential the user evaluate the products to determine whether the product is fit for the particular purpose and suitable for the user's application. All products, product specifications, availability and data are subject to change without notice, and may vary by region or country.



Donaldson.

[astgroup.ca](http://astgroup.ca)



**AST GROUP**  
OF COMPANIES

905-821-8860



**Air Separation  
Technologies Inc.**  
[astcanada.ca](http://astcanada.ca)



**AST**  
Engineering Inc.  
[astengineering.ca](http://astengineering.ca)



**AST**  
Mechanical Inc.  
[astmechanical.ca](http://astmechanical.ca)

**STEVENSON SPRINKLER**<sup>1-1</sup>.CA  
& Fire Protection Ltd.  
[stevenson sprinkler.ca](http://stevenson sprinkler.ca)