

ELEVATOR™ SERIES

Elevator™ SuperSac Filling Vacuum

19,440 Combinations. One will work perfectly for you.

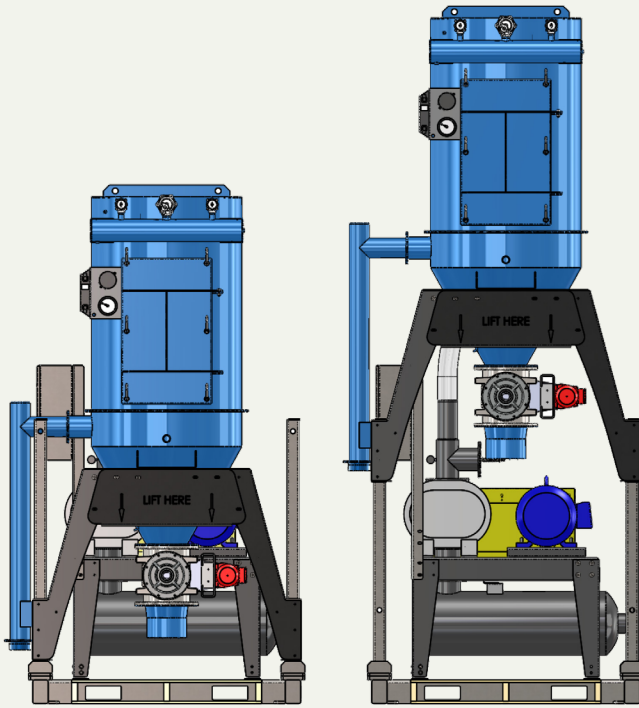

- Reliable operation with pre-engineered options for explosive powders.
- Filters so good they last years, not months. Low, low cost of operation.
- Collect material into a Super Sac, Gaylord box or into a drum.

The Elevator™ lets you cleanup spills anywhere. Take control of silica materials or explosive powders.

The Elevator™ industrial vacuum has a huge number of configurations to meet any application, including yours.

Transport to your work area, lift the separator and pin it in place. Now you get power comparable to a vacuum truck, but in a portable system that safely loads material directly into sacks, boxes or drums.

Let us help you configure a durable industrial vacuum that your workers will actually use.



The Elevator™ makes a perfect central vac.

ELEVATOR™ SERIES**Elevator™ Overview**

Fill Super Sacs, drums, or Gaylords quickly and easily.

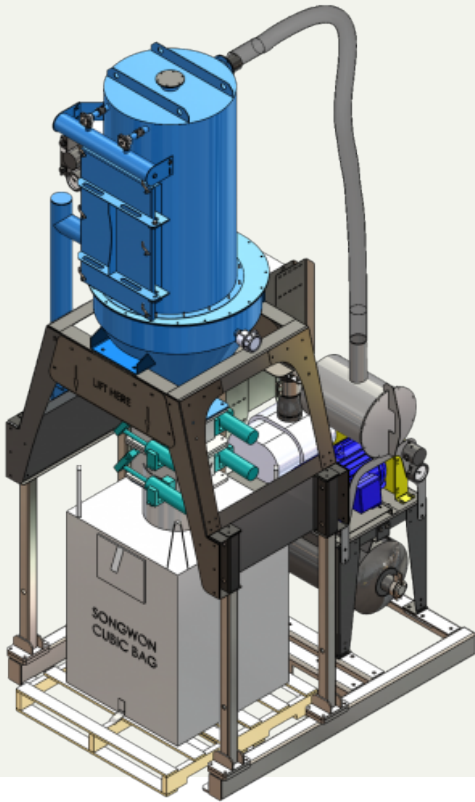

The Elevator™ is an industrial class vacuum designed to fill Super Sacs, Gaylord boxes, plastic totes, and drums. Use it as a portable, or connect it to a piping system and use it as a central vac.

It's a DuroVac™!

The Elevator™ works with the lowest possible maintenance costs. To do that the system needs to work perfectly. Our reps are the best of the best, and they'll help you select a reliable system that fits your needs.

The people at DuroVac™ have over 200 years combined experience. Our mission is to design the world's most robust and reliable vacuums. Then we back up everything we sell with the world's best warranty – even the filter life.

Compact & Versatile

The Elevator™ has a simple, small footprint, so you can set up almost anywhere.

Need a "ready to go" central vac? You'll save thousands in installation because everything is pre-wired, factory tested, and ready to work.

In most cases, connection to compressed air for filter cleaning is not required to operate perfectly.



**IF YOU CAN HOLD IT IN YOUR
HAND, WE'LL BUILD YOU A VAC
THAT WORKS PERFECTLY.**

ELEVATOR™ SERIES

Elevator™ Benefits & Features

Ingenious design features give you best possible ROI.

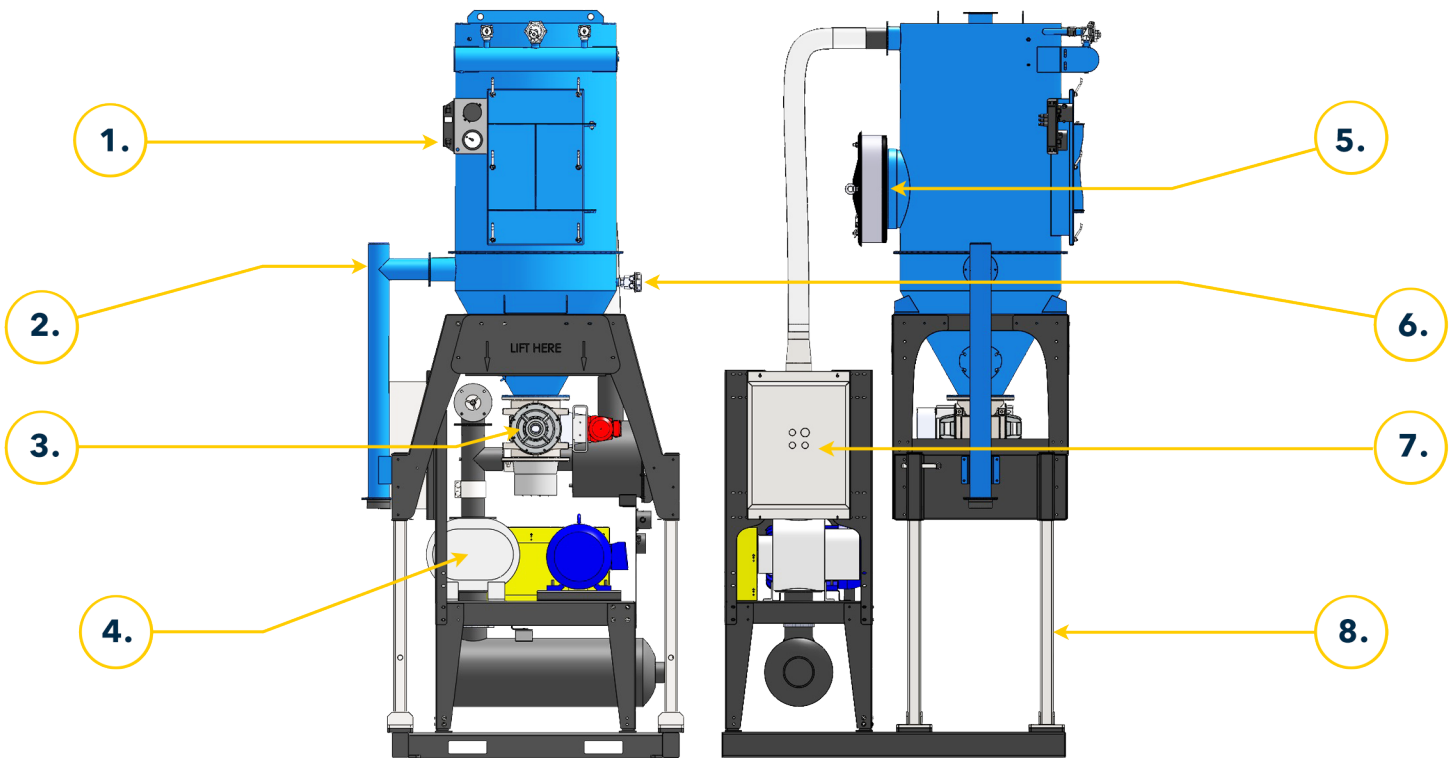

1. ULTIMATE FILTRATION

The most trouble-free filters in the industry. Many of our customers have had their machines five years and not yet replaced their filters!

2. ABRASION-PROOF INLET

Exclusive "material impact" inlet will never abrade. Easy connection height.

3. MANY DISCHARGE CHOICES

Choose from an NFPA compatible rotary valve or abrasion-proof double dump, or slide guide.

4. GIANT SUCTION POWER

A positive displacement vacuum pump achieves very high power. Hoses and piping almost always unplug themselves.

5. NFPA COMPLIANT

For combustible dust applications, the Elevator™ is configured with accessories to meet the latest NFPA codes.

6. LEVEL SWITCH

Auto-shut down with light on high level.

7. NEMA 4 ELECTRICAL

Class 2 Div 2 electrical is standard for indoor / outdoor use. All electrical components are UL & CSA certified.

8. ULTIMATE VERSATILITY

Use as a portable or as a pre-wired and tested central vacuum. Just lift up and pin to easily fill 4x4x4 foot Super Sacs, boxes, and drums. Fits your 60A plugs.

ELEVATOR™ SERIES

Elevator™ Options & Upgrades

Configure a vacuum perfect for your application.



Thousands of Solutions

The Elevator™ is an industrial class vacuum that configures in thousands of ways. So you'll get the long lasting cleaning system you need to handle just about any type of fine powder, chip, sand, and gravel.

Your system is designed as a completely pre-assembled machine. It's wired and tested in-shop, then delivered ready to work. Instant setup lowers on-site install time by days and saves thousands when used as a central vac.

Perfect for Silica Control

Abrasion resistant double-dump valves allow continuous productivity while safely filling supersac bags. Ample room below allows for 2000 lb capacity bags on a skid.

Combustible Dust

The Elevator™ is pre-engineered to be NFPA 68-2018 and 654-2017 compliant. Fully grounded, and used with a flameless vent, the EL Series is ready to work in any Class 2 Div II classified atmosphere (Zone 22).

Make DuroVac your partner. We are fully aware of the code requirements for your combustible dust application, and we're ready to help you.



Lift and pin the filter into place and get to work.
Built to be extremely reliable.

WITH ITS TOUGH, TESTED DESIGN, the Elevator™ lets you vacuum heavy abrasives, or combustible dusts, with complete reliability. Move it anywhere by forklift, so you can tackle production spills and day-to-day cleaning quickly and easily.

- Exclusive abrasion-proof inlet with cam type hose connection easy operator height.
- Self-cleaning filters that last 10x longer than industry standard.
- Easy upgrade to 99.97% HEPA filter.
- Standard NFPA Compliant options.

Specifications

Model Number	EL20	EL25	EL30	EL40
System Horsepower	20 Hp	25 Hp	30 Hp	40 Hp
Number of Hoses	1 x 2.5" 2 x 2.0"	1 x 3.0" 3 x 2.0"	1 x 3.0" 3 x 2.0"	1 x 4.0" 2 x 2.5"
Performance (TPH)¹	3.5	4.0	4.5	6.0
Air Flow - Inlet (CFM)	400	525	650	860
Vacuum (Maximum)	16" Hg.	16" Hg.	16" Hg.	16" Hg.
Standard Filter Area (ft²)	85.5	85.5	85.5	121.0
Pulse Filter Area (ft²)	120.0	120.0	120.0	210.0
Hopper Volume (Yrd³)	8.0	8.0	8.0	8.0
Noise Level @ 3ft (dBa)	85	85	85	85
Weight (lbs)	2360	2550	2860	3080

1. Performance is rated for foundry sand with a 50 ft long hose. Lighter material moves faster, heavier material slower. Moves 1 lb/min less for every 1 ft longer hose.



Reliable, simple operation with a tough vacuum that just keeps on working.

No matter what material you have, you'll get a vacuum cleaning system that will work perfectly for years with minimal maintenance. And with all components picked from stock, we can ship out your new machine fast.

astgroup.ca



905-821-8860

