

PORTABLE SERIES

DVP Portable & Central Packaged Vacuums

High Vacuum Performance with 99.9% Filtration

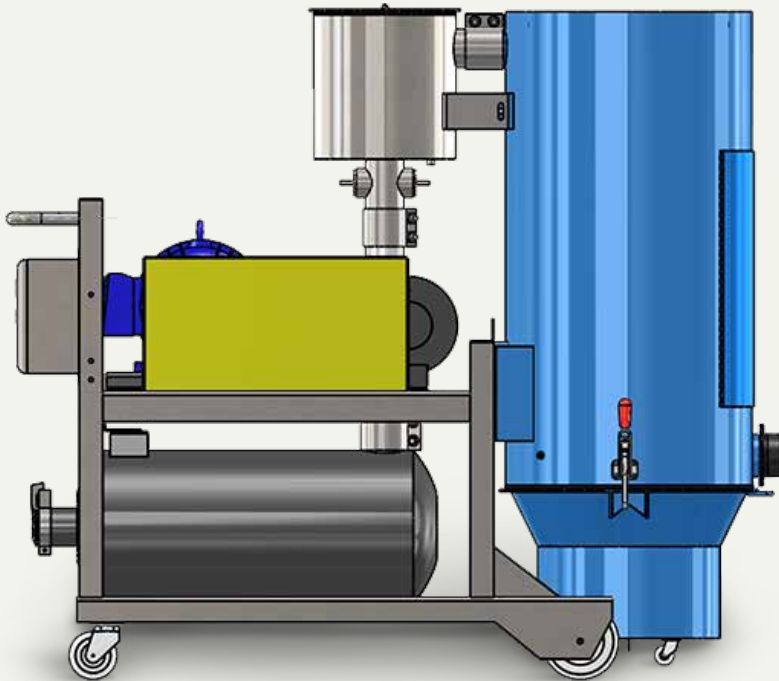

- Filters so good they last years, not months. Low, low cost of ownership.
- Triple filtration assures trouble-free operation even with super-fine powder.
- The high performance suction you need in the easy-to-move DV frame.



The Portable DVP industrial vacuum offers tremendous performance with long hoses and heavy powders.

Designed with filters so good you'll never have a drop in performance as you vacuum, even with fines that plug other vacuums. Now you can vacuum continuously without stopping work to clean filters.

When you need serious power, you need a positive displacement vacuum producer. That's because it actually pulls harder as the job gets tougher.



The Portable DVP industrial vac makes a great compact central system.

TRIPLE FILTRATION means hassle-free operation when you're handling fine powders. At 99.9% efficiency, the primary filter media won't easily clog, so performance never drops as the hopper fills. Vacuum continuously without stopping the system to shake the filters.

- First-stage impaction separator with internal baffle plate to protect against abrasion.
- Large main filter in a baghouse-type format.
- 99.97% HEPA filter for silica safe operation.

Specifications

Model Number	DVP15	DVP20	DVP25	DVP20	DVP25	DVP30*
Blower Model	5L	5L	5L	6M	6M	6M
System Horsepower	15 Hp	20 Hp	25 Hp	20 Hp	25 Hp	30 Hp
Number of Hoses	1 x 2.0" 2 x 1.5"	1 x 2.5" 3 x 1.5"	2 x 2.0"	1 x 2.5" 3 x 1.5"	2 x 2.0"	2 x 2.0" (3 x 2.0") ¹
Performance (lb/min)	85	105	133	105	133	166
Air Flow - Inlet (CFM)	360	520	600	400	500	650
Vacuum (Maximum)	12" Hg.	12" Hg.	14" Hg.	16" Hg.	16" Hg.	16" Hg.
Primary Filter (ft²)	61.6	61.6	61.6	61.6	61.6	61.6
Storage (US Gal)	27.0	27.0	27.0	27.0	27.0	27.0
Noise Level @ 3ft (dBA)	85	85	85	85	85	85
Weight (lbs)	735	795	935	795	935	1030

1. Configuration for light materials only.

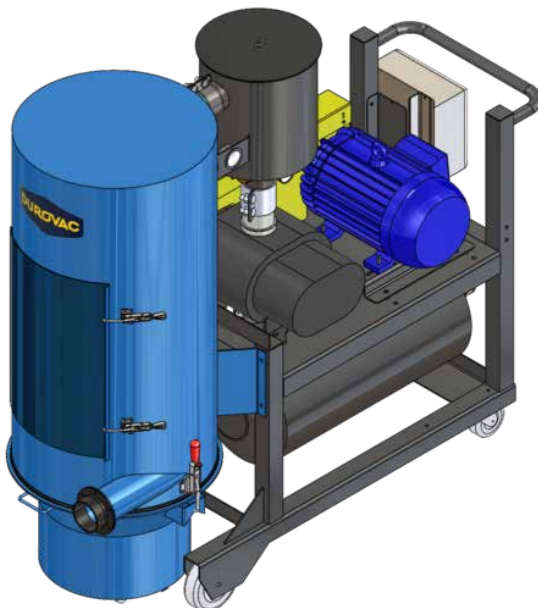

When you need to power long hoses and vacuum heavy powders and granules.

With its positive displacement vac pump, the DVP will make short work of your worst cleaning problems. And the long lasting filters mean that maintenance is extremely low.

Need more storage? The DVP industrial vacuum normally requires a pre-separator to collect bulk material. Contact us today to discuss.

astgroup.ca



AST GROUP
OF COMPANIES

905-821-8860