

Delta P Plus Control

Installation and Operation Manual

Installation, Operation and Service Manual

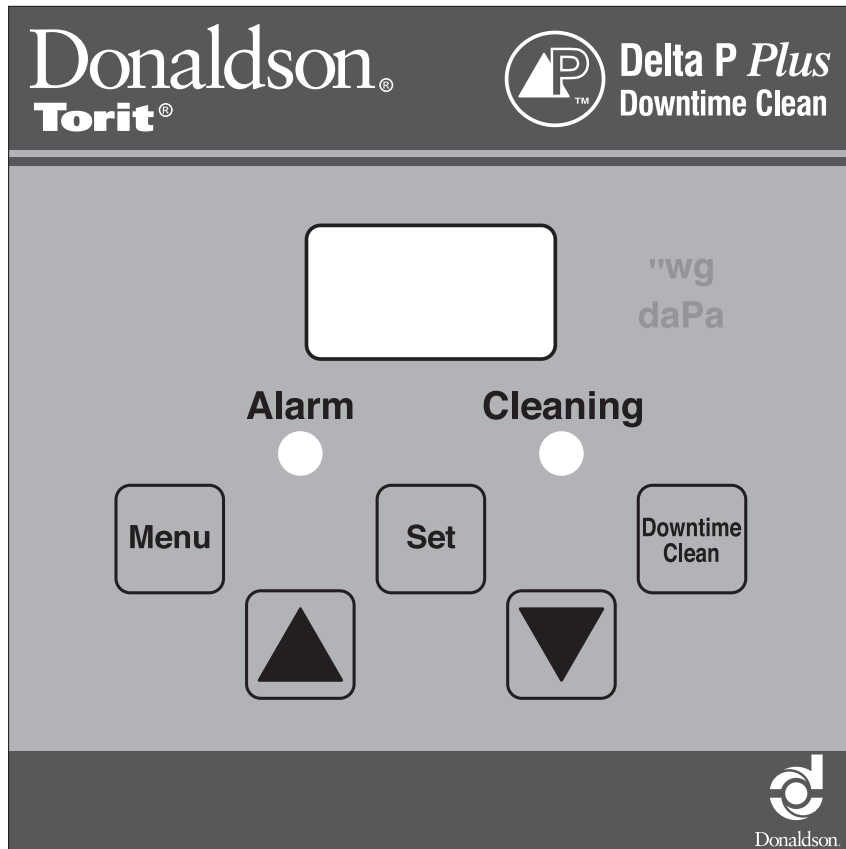

This manual contains specific precautions related to worker safety. The hazard alert image denotes safety related instructions and warnings in this manual. DO NOT install, operate, or perform maintenance on this collector until you have read and understood the instructions, precautions and warnings contained within this manual.

IMPORTANT NOTES

This manual has been supplied to assist with the installation, operation and maintenance for the collector purchased. Please read the manual before installing, operating, or performing maintenance on the collector as it contains specific precautions for worker safety. It is the owner's responsibility to ensure that this manual is available for use by installers, operators and maintenance personnel that will be working with this collector. This manual is the property of the owner and should be left with the collector when installation has been completed. **DO NOT** operate this collector until you have read and understood the instructions and warnings located in the installation and operation manual.

For additional copies of this manual, contact Donaldson Torit.



The Safety Alert Symbol indicates a hazardous situation which, if not avoided could result in death or serious injury. Obey all safety messages following this symbol to avoid possible injury or death. The possible hazards are explained in the associated text messages.

NOTICE

NOTICE indicates a potential situation or practice which is not expected to result in personal injury, but which if not avoided, may result in damage to equipment.

Contents

- IMPORTANT NOTES 2
- 1 Safety Communication 4
- 2 Product Description 6
- 3 Operation..... 6
- 4 Product Service 7
 - Operational Checklist 7
 - Troubleshooting 8
 - Replacement Parts 10
- Appendix A - Installation 11
 - Installation 12
 - Location and Site Selection 12
 - Delivery and Inspection 12
 - Unloading and Positioning 12
 - Electrical Wiring 13
 - Setpoint Adjustments 14
 - Quick Start Instructions 14
 - Adjustments 14
 - Password Protected Settings 14
 - Delta P Plus Control Calibration 16
 - Optional Settings 18
 - Product Information 20
 - Service Notes 20
- Donaldson Industrial Air Filtration Warranty..... 21

1 Safety Communication



Improper operation of dust collectors and/or dust control systems may contribute to conditions in a work area or facility which could result in severe personal injury, and product or property damage. All dust collection equipment should be used only for its intended purpose and should be properly selected and sized for its intended use.

Process owners have important responsibilities relating to identifying and addressing potential hazards in their processes. When the potential for handling combustible dust exists within a process the process owner should include combustion hazards in their risk management activities and should comply with applicable codes and standards related to combustible dust.

Electrical installation must be performed by a qualified electrician.

This equipment is not designed to support site ducts, piping, or electrical services. All ducts, piping, or electrical services must be adequately supported to prevent injury and/or property damage.

Site selection must account for wind, seismic zone, and other load conditions.

Equipment may reach peak sound pressure levels above 80 dB (A). Noise levels should be considered when selecting collector location.

Most dusts present safety and health hazards that require precautions. Wear eye, respiratory, head and other protection equipment suitable for the type of dust.

Some components may be heavier than they appear. Use appropriate lifting methods to avoid personal injury and/or property damage.

Combustible Dust Hazards

Among other considerations, the current NFPA standards require owners whose processes involve potentially combustible materials to have a current Dust Hazard Analysis, which can serve as the foundation for their process hazard mitigation strategy. Mitigation may include but is not limited to:

- Prevention of all ignition sources from entering any dust collection equipment.
- Selection and implementation of fire and explosion mitigation, suppression, and isolation strategies appropriate for the risks in their process.
- Development and use of work practices to maintain safe operating conditions, and to ensure combustible dust does not accumulate within their plant or process equipment.

Donaldson designs, manufactures, and sells industrial air filtration products for a wide variety of applications. Some applications may include processes or materials with inherent fire and explosion hazards. Donaldson is neither an expert nor a certified consultant in fire, spark, or explosion detection, suppression, or control. Donaldson does not provide engineering consulting services related to process or dust hazard analyses, or code and standard compliance. Complying with applicable codes and standards and managing the risks associated with the process or materials remains the responsibility of the process owner/operator. Donaldson may provide referrals to consultants, suppliers of equipment or services related to the detection and/or mitigation of sparks, fires and/or explosions, but Donaldson does not assume responsibility for any such referrals, nor does Donaldson assume any liability for the fitness of a mitigation strategy or product for a particular installation or application. The process owner's final selection of dust collectors and risk mitigation strategies should be based on the outcome of a Dust Hazard / Process Hazard Analysis performed by the process owner. Although early engagement of a dust collector supplier provides helpful insights on the availability and features of various products, process owners should consult with a combustible dust expert and/or a process safety expert before making actual product and mitigation strategy selections.

Donaldson recommends that all industrial air filtration system designs be reviewed and approved by an expert consultant who is responsible for the integrity of the system design and compliance with applicable codes and standards. It is the process owner's responsibility to understand the risks in their process and mitigate those risks in accordance with all applicable laws, regulations and standards, including those published by the NFPA. Donaldson also recommends that proper maintenance and housekeeping procedures and work practices be evaluated, developed, and followed to maintain any industrial air filtration products in safe operating condition.

Many factors beyond the control of Donaldson can affect the use and performance of Donaldson products in a particular application, including the conditions under which the product is used. Since these factors are uniquely within the user's knowledge and control, it is essential the user evaluate the Donaldson products to determine whether the product is fit for the particular purpose and suitable for the user's application. All products, product specifications, and data (airflow, capacity, dimensions, or availability) are subject to change without notice, and may vary by region or country.

2 Product Description

The Delta P Plus Controller monitors the differential pressure between the clean-air and dirty-air plenums, providing a visual display of the filter condition. When combined with a pulse timer, it manages the pressure drop by turning the cleaning mechanism On and Off at the chosen limits. There are three (3) set points: High Pressure On, Low Pressure Off, and Alarm. The first two, High Pressure On and Low Pressure Off, control the filter cleaning system. The third, Alarm, provides a relay output to activate an external alarm supplied by others.

The user can program the Delta P Plus Controller to pulse while the collector is running, to maintain a relatively constant pressure drop across the filters, pulse only after the collector is shut down (after-shift cleaning), or a combination of both, cleaning while running as well as end of the shift.

3 Operation

Three cleaning modes, Differential Pressure Cleaning (DFF), Downtime Cleaning (DTC), and Combined Differential and Downtime Cleaning (ALL) are available with this controller and can be individually chosen by the user.

- Differential Pressure Cleaning (DFF) - When the differential pressure drop reaches the controller's HIGH setpoint, the controller closes an output relay initiating the cleaning cycle. When the differential pressure decreases to the LOW setpoint, the relay opens and the cleaning cycle stops. This sequence continues as long as the collector is running, maintaining the differential pressure drop within a specified range.
- Downtime Cleaning (DTC) – The Delta P Plus controller monitors for the differential pressure drop to exceed the LOW setpoint. (Indicates the blower has been started). When the differential pressure drop later approaches zero (indicating the blower has been shut down), the Delta P Plus engages the cleaning cycle for a pre-selected time. A delay timer allows the blower to come to a stop before the cleaning cycle starts.

The delay timer and cleaning cycle durations are both user adjustable but password protected.

- Combined Differential and Downtime Cleaning (ALL) –The ALL mode combines the two functions described above, maintaining the differential pressure drop in a specified range, then initiating a down-time cleaning cycle when the differential pressure drop approaches zero. The downtime cleaning function can be toggled on or off from the keyboard.

Note: The DTC and ALL cleaning modes incorporate compressed air cleaning of the filters when the main collector fan is not running. This may result in collected material “drifting” out the inlet duct of the collector. An isolation valve in the inlet duct of the collector can reduce or eliminate that drifting.

Consideration should be made on the use of the DTC or ALL cleaning mode on small collectors where the relatively low volume of the collector may produce pressure spikes with each pulse of the cleaning cycle. Such pressure spikes may accelerate the fatigue, or damage of ancillary items such as pressure sensors or explosion relief panels.

Alarm

The Alarm setpoint is set to a higher setting than the High Pressure On used to start the filter cleaning cycle. It indicates situations when the cleaning system cannot reduce the pressure drop due to cleaning system failure, lack of compressed air, or the end of the filter's useful life. There is a time delay prior to setting the Alarm to prevent nuisance trips. The Delta P Plus Controller also provides an input connection for a remote Alarm reset.

4 Product Service



During any service activities there is some potential for exposure to the mist in the collector. Most mists present safety and health hazards that require precautions. Wear eye, respiratory, head and other protection equipment suitable for the type of mist when performing any service activities.

Use appropriate access equipment and procedures. Note the standard collector is not equipped with access platforms unless noted on the specification drawings.

LOCK-OUT all energy sources prior to performing any service or maintenance on the equipment.

Electrical service or maintenance work must be performed by a qualified electrician and comply with all applicable national and local codes.

This equipment may start or stop unexpectedly from a remote location. Turn power off and lock out all power before performing service or maintenance work.

Operational Checklist

1. Visually confirm Delta P display is illuminated and displaying differential pressure.
2. Observe and address any alarm conditions.
3. If cleaning light is on, confirm that the collector is advancing through the cleaning process.

Troubleshooting

Problem	Probable Cause	Remedy
No display on the Delta P Plus Control	No power to the control	Use a voltmeter to check for voltage at Terminal TB1.
	Fuse blown	Check the fuse in the F1 fuse tower. Replace if necessary.
Display on the Delta P Plus control does not read zero when at rest	Out of calibration	Disconnect pressure tubing. See Delta P Plus Control Calibration.
	With collector discharging outside, differential pressure is present from indoor to outdoor	Recalibrate with the pressure tubing attached as described in Delta P Plus Control Calibration.
Display reads “ _ _ _ ”	Pressure out of the allowable range	Check that high and low pressure tubing is attached and not leaking. Use a differential pressure measurement device to verify that the actual pressure does not exceed 20 “wg.
Delta P Plus Control ON, but cleaning system does not start	Not wired to the timing board correctly	Connect the pressure switch on the timer board to Terminals 7 and 8 on TB3.
	Faulty relay	Using a multimeter, test relay for proper closure. Replace if necessary.
	Pressure tubing disconnected, ruptured, or plugged	Check tubing for kinks, breaks, contamination, or loose connections.
Pulse cleaning never stops	Pressure switch terminals on the timer board jumpered	Remove jumper wire on solid-state timer board before wiring to Delta P Plus Control.
	Pressure switch not wired to the timer board correctly	Connect the pressure switch on the timer board to terminal 7 (normally open) and Terminal 8 (common) on TB3.
	High or low setpoint not adjusted for system conditions	Adjust setpoints to current conditions. See Setpoint Adjustment.
	Pressure tubing disconnected, ruptured or plugged.	Check tubing for kinks, breaks, contamination, or loose connections.
Alarm light is ON	Alarm setpoint too low	Adjust to a higher value.
	Excess pressure drop	Check cleaning system and compressed-air supply. Replace filter cartridges if filters do not clean down.
	Pressure tubing disconnected, ruptured, or plugged	Check tubing for kinks, breaks, contamination, or loose connections.

Problem	Probable Cause	Remedy
Delta P Plus arrow keys do not work	Improper operation	Press MENU and choose a parameter, then press SET prior to using the arrow keys.
	Programming keys disabled	Remove the Program Disable jumper from Terminals 3 and 4 on TB2.
Cleaning light is ON, but cleaning system not functioning	Improper wiring	Check wiring between the Delta P Plus Control and the timer board, and between the timer board and solenoid valve coils.
	Defective solenoids	Check all solenoid coil for proper operation.
	Timer board not powered	Check power ON light on timer board's LED display. If not illuminated, check the supply voltage to the timer board. Check the fuse on the timer board. Replace if necessary.
	Timer board defective	If LED is illuminated, observe the output display. Install a temporary jumper across the pressure switch terminals. Output LED's should flash in sequence. Check output using a multimeter set to 150 VAC range, measure from SOL COM to a solenoid output. The needle will deflect when LED flashes for that output if voltage is present. If LEDs do not flash, or if no voltage is present at output terminals during flash, replace the board.
Downtime cleaning too long or too short duration	Parameter setup	Reset the value in Parameter P10.
Pressure display changes value up and down rapidly	Parameter setup	Reset the value in parameter P12.

Replacement Parts

1

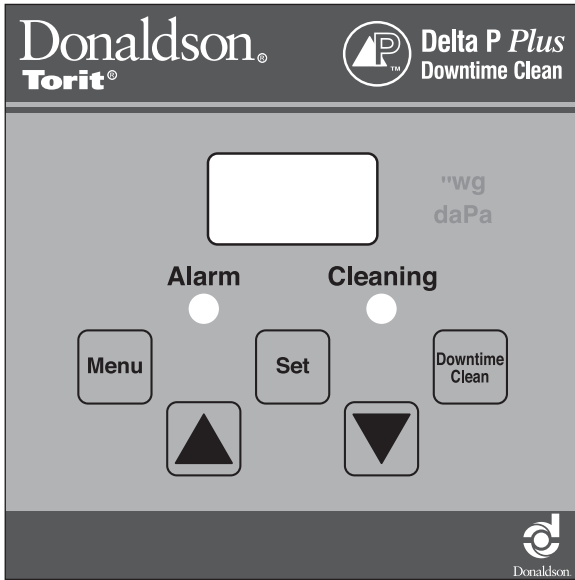

Keypad Label

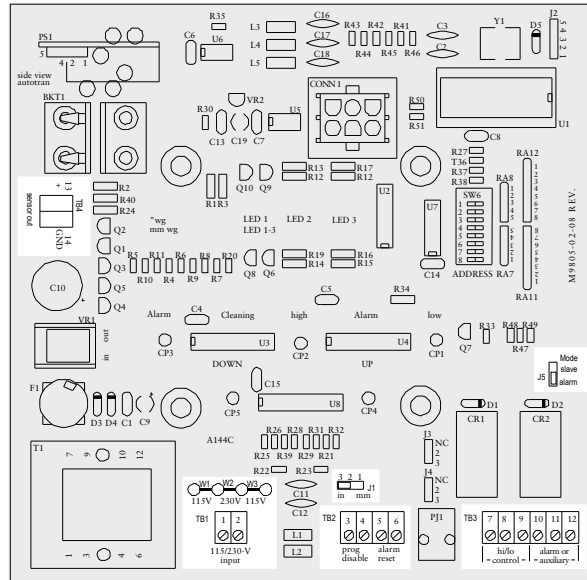

Printed Circuit Board

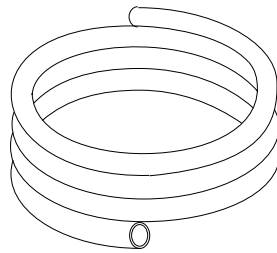

2

Plastic Tubing

Delta P Control

Item	Part Number	Description	Model
1	7053601	Delta P Plus Control (includes keypad label and printed circuit board)	All
2	2334200	Plastic Tubing, Vinyl, 3/16-in ID, 5/16-in OD	All

Appendix A - Installation

Installation



Electrical Installation (including bonding and grounding of the collector) must be performed by a qualified electrician. Do not install in classified hazardous atmospheres without an enclosure rated for the application. Service must be performed by trained and qualified maintenance personnel. This equipment may start or stop unexpectedly from a remote location.

Location and Site Selection



Codes may regulate recirculating filtered air in your facility. Consult with the appropriate authorities having jurisdiction to ensure compliance with all national and local codes regarding recirculating filtered air.

Equipment location must conform to all codes and standards, should be suitable for the type of dust being handled and should ensure easy access for service and utility connections. Site selection must account for wind, seismic zone and other load conditions.

Delivery and Inspection

Upon arrival inspect equipment and report any damage to delivery carrier. File any damage claims with the delivery carrier. Request a written inspection report from the Claims Inspector to substantiate all damage claims.

Compare the equipment received with the description of product ordered. Report any incomplete shipments to the delivery carrier and your Donaldson Torit representative.

Unloading and Positioning



Equipment should be lifted only by qualified crane or fork truck operators.

Failure to lift the equipment correctly can result in severe personal injury and/or property damage.

1. Remove any crates or shipping straps.
2. Lift the packaged collector from transport container.
3. Inspect for any damage and/or missing parts and report to freight carrier.
4. Check for any hardware which may have become loose during shipment and tighten as necessary.

Electrical Wiring



Electrical installation, service, or maintenance work must be performed by a qualified electrician and comply with all applicable national and local codes.

This equipment may start or stop unexpectedly from a remote location.

Turn power off and lock out all power before performing service or maintenance work.

The appropriate wiring schematic and electrical rating must be used. See collector's rating plate for required voltage.

Do not install in classified hazardous atmospheres without an enclosure rated for the application.

NOTICE

The Delta P Plus Control is factory set for 115-V. To operate at 230-V, the jumper settings on the printed circuit board must be changed. See Optional Settings.

1. Choose a location near the collector that permits access to the keypad for adjustments and observation of the pressure drop. If possible, mount the control indoors.
2. Mount the control enclosure using four self-drilling, self-tapping screws.

NOTICE

Use vibration isolators in high vibration areas.

3. Connect the output contacts to the correct contact terminals of the pulse control time per the supplied electrical drawing. These connections will start/stop the cleaning cycle.
4. Wire the auxiliary alarm circuit, if desired. This relay output can be used to activate visual or audible alarms provided by others. If not wired, the alarm LED light on the control panel will be the only indication of a fault condition.

NOTICE

Use proper grounding and handling procedures to prevent permanent damage to this device. Handle the printed circuit board by the edges only. Do not touch the socketed E2PROM pins.

5. Wire all remaining auxiliary connections at this time. See the Optional Settings for a list of these options.
6. Thirty-five feet of plastic tubing is supplied with the control and must be cut in two sections. Connect one section of tubing from the control enclosure's high-pressure port to the pressure tap on the dirty-air plenum. Connect the remaining section of tubing from the control enclosure's low-pressure port to the pressure tap on the clean-air plenum. Additional tubing can be ordered from your representative.
7. Apply power to the control. Set the high- and low-pressure setpoints to start and stop the cleaning process. Set the alarm setpoint to activate the alarm display. See Control Calibration.

Setpoint Adjustments

Quick Start Instructions

1. Press the MENU key, Lo appears. Press the SET key and the current value appears in the display. Use the arrow keys ▲ ▼ to change this value. Press SET again, and the display will blink twice, indicating that the new set point has been accepted.

The Lo setting selects the differential pressure drop value used to stop the pulse cleaning cycle, 2.0" w.g. is a typical initial value.

NOTICE

For collectors with pleated bags, it is recommended that the low setpoint be set to no lower than 0.5" w.g. below the high setpoint.

2. Press the MENU key twice, Hi appears. Press the SET key and the current value appears in the display. Use the arrow keys ▲ ▼ to change this value. Press SET again, and the display will blink twice, indicating that the new set point has been accepted.

The Hi setting selects the differential pressure drop value used to start the pulse cleaning cycle, 4.0" w.g. is a typical initial value.

3. Press the MENU key three times, AL appears. Press the set key and the current value appears in the display. Use the arrow keys ▲ ▼ to change this value. Press SET again, and the display will blink twice, indicating that the new setpoint has been accepted.

The AL setting selects the differential pressure drop value used to close the Alarm relay and turn on the Alarm pilot light on the display.

4. Press the DOWNTIME CLEAN key, and the display will read either On or Off. Pressing the same key again will toggle the reading [On to Off or Off to On]. Press the SET key to lock in your choice.

Adjustments

1. Pressing the MENU key repeatedly scrolls through the following programming choices:

Lo — Low set point

Hi — High set point

AL — Alarm set point

rtn — Return to reading current conditions

PAS — Password (for access to secured functions)

3. The SET key shows current value and locks in values after adjustments.
4. The DOWNTIME Clean button toggles the function on and off when available.
5. Not pressing any buttons for 10 seconds allows the control to return to monitoring the filter system.

Password Protected Settings

To reach the password protected settings, press the MENU key 5 times, the display will show PAS.

Press the SET key, use the up arrow key ▲ to set the value to "4", press set again.

When the display blinks twice, press the MENU key repeatedly until you reach the parameter you wish to change.

Once you have selected a parameter, use the arrow keys ▲ ▼ to change the value within the setting range shown in the table.

Press the SET key to lock in the value.

Parameters	Description	Setting Range	Factory Default	Units	Function
		ALL			ALL - Combines differential pressure (Delta P) based cleaning with downtime cleaning ON/OFF selectable from keypad.
P 6	Mode Select	DTC	ALL	--	DTC - Filters downtime cleaned only, not based on filter Delta P.
		DFF			DFF - Filter cleaning based on Delta P with downtime cleaning not available.
P 7	Display Units 0 = in. w.g. 1 = daPa	0 - 1	0	--	Selects units of measure for the digital display.
P 8	Downtime Start Relay	30 - 99	30	Seconds	Adjustable time lag between the pressure dropping below the value set in parameter P 11 and the start of downtime cleaning.
P 9	Downtime Pressure Enable Relay	30 - 99	30	Seconds	Adjustable time required to be above the value set as the Low Set Point (Lo) before the downtime feature is enabled.
P 10	Downtime Cleaning Time	1 - 999	10	Minutes	The amount of time the downtime cleaning will continue once the time set in P 9 expires.*
P 11	Downtime Start Pressure	0 - 9.6 (245)	0.3 (13)	In. Water (daPa)	The falling pressure that triggers the downtime cleaning sequence.**
P 12	Pressure Sensor Input Filtering	0 - 2	1	--	Sets the time used for Delta P value averaging (0 = 250 ms, 1 = 2.5 sec, 2 = 10 sec).
P 13	Reset to Factory Defaults	0 - 1	0	--	0 = No Reset 1 = Reset
P 14	Zero Offset	0 - 1	0	--	0 = No Operations 1 = Offset and Displayed Zero
P 15	Software Version	--	--	--	
P 16	Password	--	--	--	Factory password, no user adjustable items in subsequent parameters.

* If the downtime cleaning sequence is in progress and the pressure drop indicates a fan restart, the cleaning sequence will end.

** If P 11 is set as equal to or greater than the Lo value, the Lo value will automatically increase 0.2" above the P 11 value.

Delta P Plus Control Calibration

The only user calibration is the zero adjustment of the display. Due to slight changes in electronic components over time or pressure within the plant environment, the display may read something other than 0.0 while at rest. Use the following procedure to recalibrate the operating system.

1. Turn power to the Delta P Plus Control ON for a minimum of 30-minutes to stabilize the operating temperature.
2. Disconnect the pressure tubing, either leaving it to atmosphere, or connecting the two barbed fittings together with a short length of tubing.
3. Use the Menu key to select PAS.
4. Press SET, then use the arrow keys to display "4", press SET again.
5. Press the MENU key repeatedly until you reach P14.
6. Press SET, then use the arrow keys to display "1", press SET again.
7. After 10 seconds with no further button action, the display will return to reading the pressure.
8. Connect one section of tubing from the control enclosure's high-pressure port to the pressure tap on the dirty-air plenum. Connect the remaining section of tubing from the control enclosure's low-pressure port to the pressure tap on the clean-air plenum.

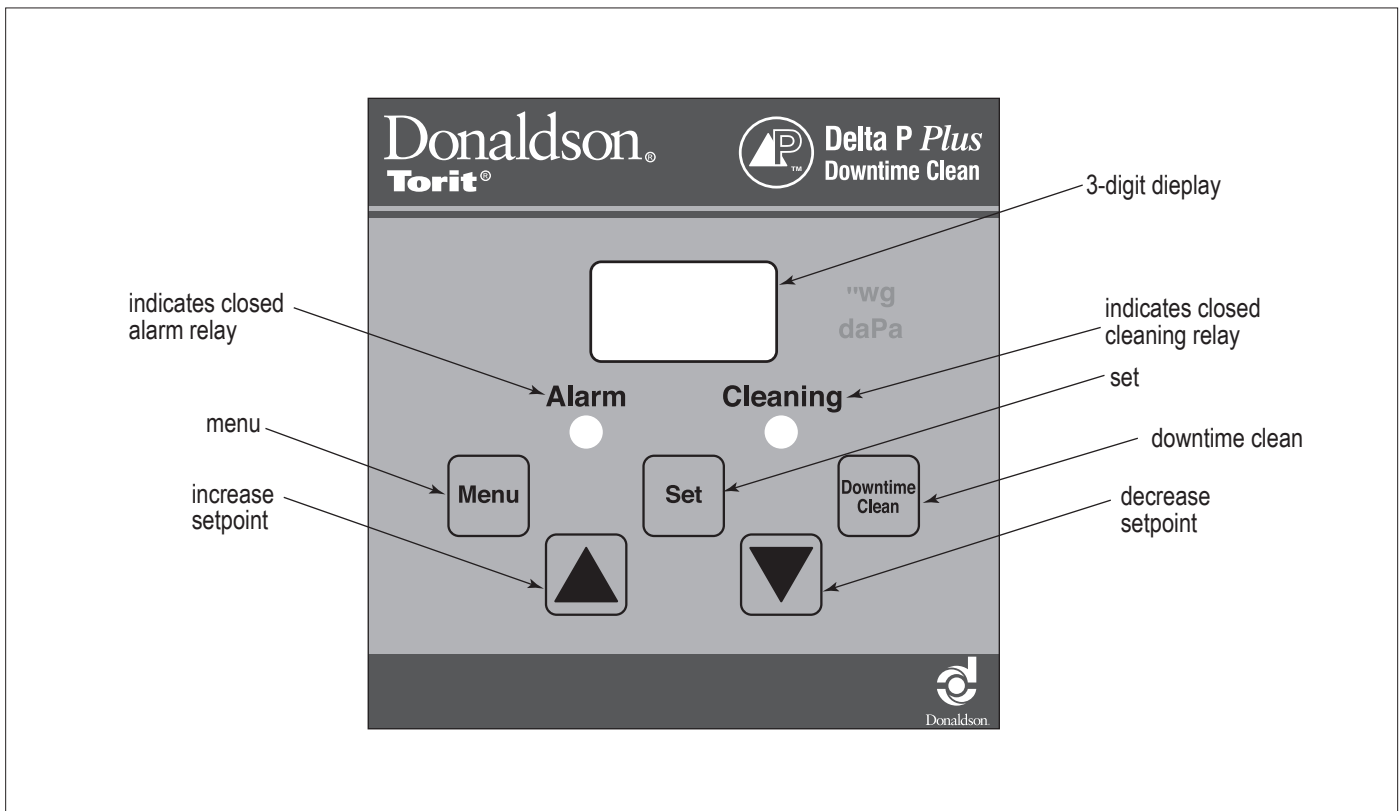

Delta P Plus Display

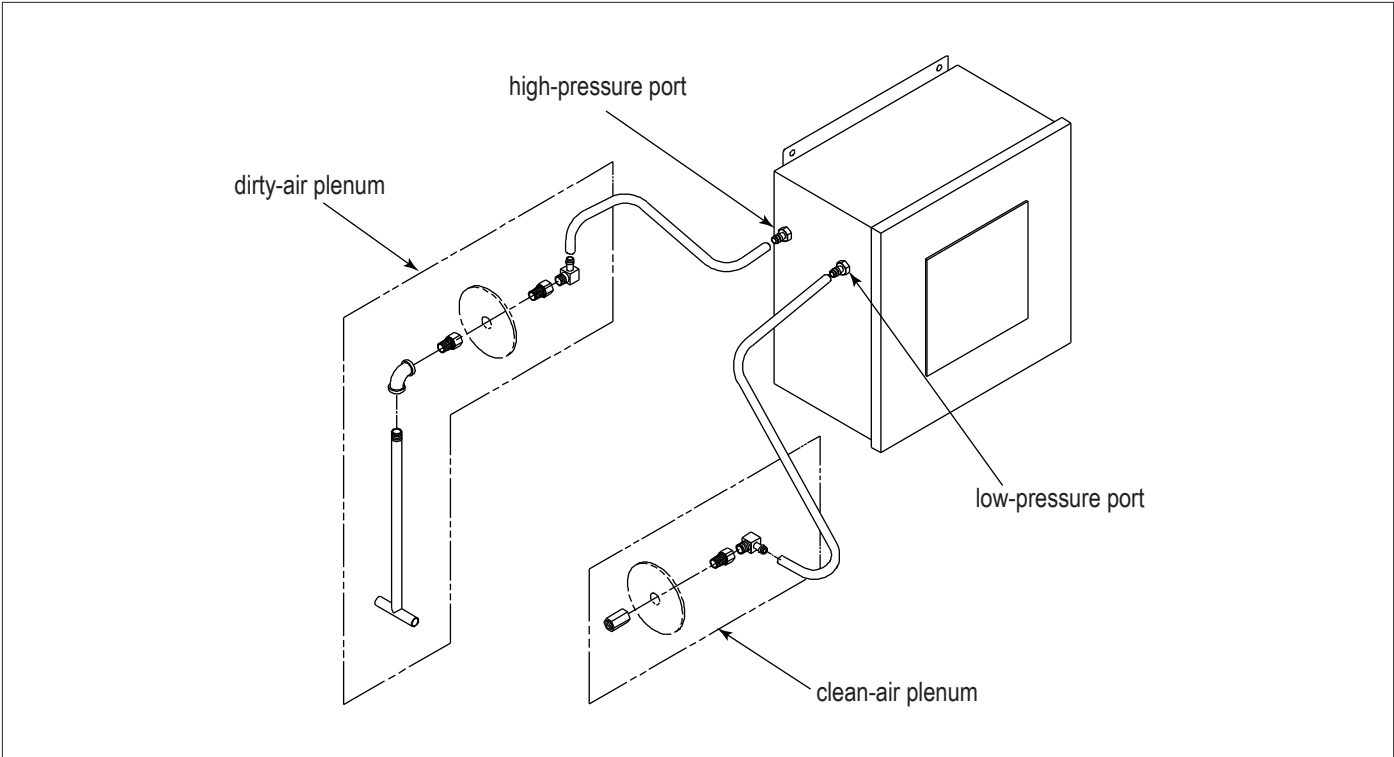

Delta P Control Installation

Optional Settings

See Printed Circuit Board illustration.

230 VAC Power Supply

To operate at 230 VAC, remove two jumpers labeled W1 and W3. Reinsert one of the jumpers in position W2.

Change from English to Metric (SI) Units

1. Turn power to the Delta P Plus Control ON.
2. Use the Menu key to select PAS.
3. Press SET, then use the arrow keys to display "4", press SET again.
4. Press the MENU key repeatedly until you reach P7.
5. Press SET, then use the arrow keys to display "0", press SET again.
6. After 10 seconds with no further button action, the display will return to reading the pressure.

Disable Setpoint Adjustment

To restrict setpoint changes, install a jumper wire across the PROG. DISABLE terminals (3 & 4) on Terminal Block 2, TB2. The current settings will still be displayed, but no changes can be made until the jumper is removed. Interrupting the jumper with a key-operated, normally-closed switch installed in the enclosure door provides temporary access to the setting functions without opening the door.

External Alarm Reset / Disable (TB2, Terminal 5 & 6)

If desired, wire the ARM RESET terminals (5 & 6) on Terminal Block 2, TB2, to a key-operated, normally-open switch. Closing the switch turns the alarm OFF.

Internal Alarm Disable (J5)

To disable the alarm internally, remove the jumper on MODE Jumper Block J5, located on the lower-right quadrant of the circuit board. Disabling the alarm relay reduces the alarm function to the ALARM LED visual display only.

Hi/Lo Control (TB3, Terminals 7, 8, & 9)

Per the wiring diagram supplied with the controller, the Hi/Lo terminals are connected to the pressure switch input on the timer board. In most cases this connection is made at the factory.

Terminal 8 is common, terminal 7 is normally open, and terminal 9 is normally closed.

Auxiliary Relay Output (TB3, Terminals 10, 11, & 12)

1. If the jumper on the MODE Jumper Block J5 is not installed, the auxiliary relay output will not function.
2. If the jumper is installed in the ALARM mode position, the auxiliary relay output activates based on the setting of the ALARM setpoint.
3. If the jumper is installed in the SLAVE mode position, the auxiliary relay output activates in parallel with the HI/LO CONTROL relay.

Terminal 11 is common, terminal 10 is normally open, and terminal 12 is normally closed.

Analog Output (TB4, Terminals 13 & 14)

Terminals 13 & 14 on Terminal Block 4, TB4, in the upper-left quadrant of the circuit board, provide a 4 to 20 mA output proportional to the 0-to-maximum span of the pressure sensor. This circuit requires a 500 ohm maximum load.

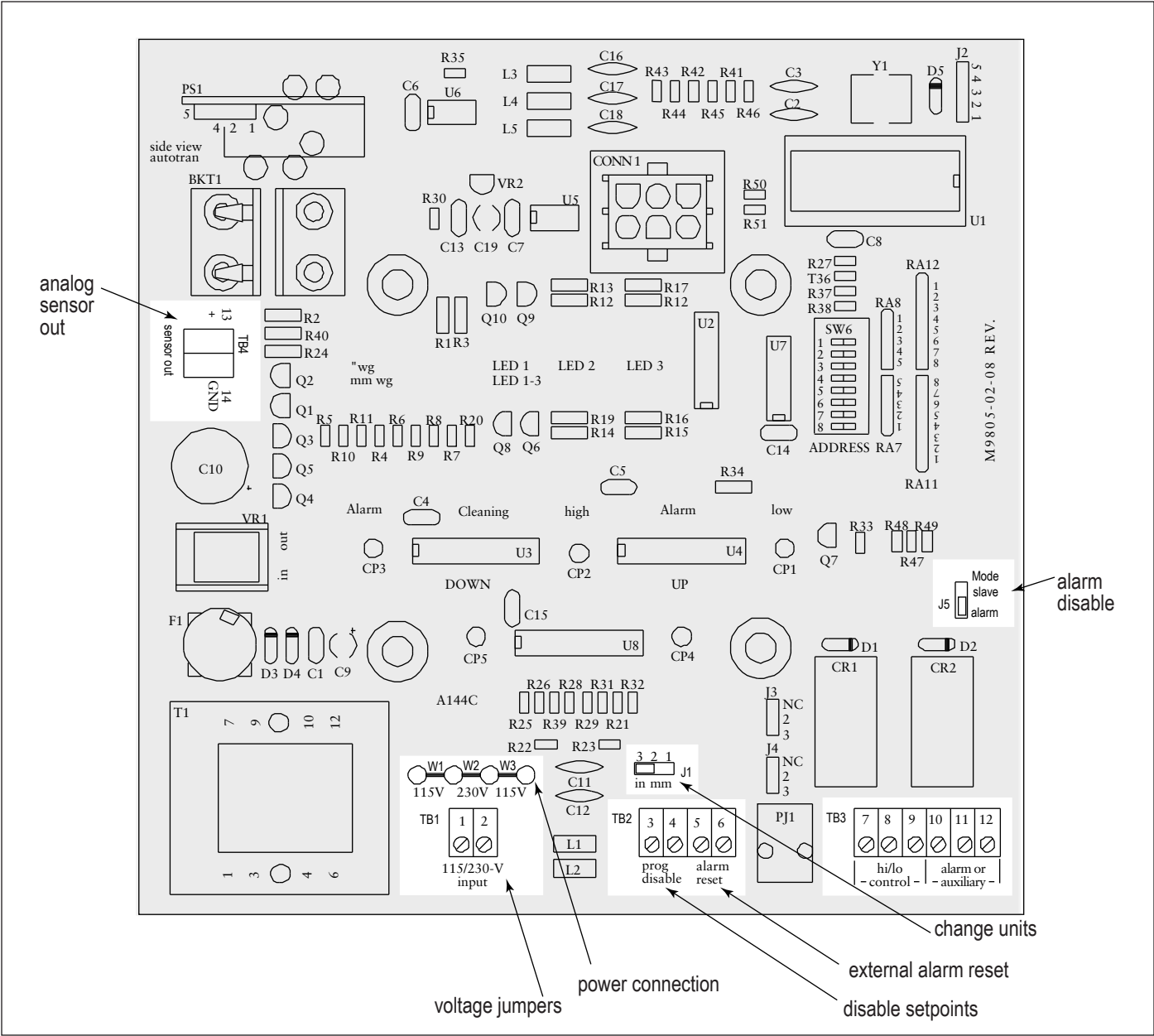

Printed Circuit Board (Optional Settings Location)

Product Information (Process Owner to complete and retain for your records)

Model Number _____ Serial Number _____

Ship Date _____ Installation Date _____

Filter Type _____

Collected Dust _____

Dust Properties: Kst _____ Pmax _____ MIE _____ MEC _____

Accessories _____

Other _____

Service Notes

Date	Service Performed	Notes

Donaldson Industrial Air Filtration Warranty

Donaldson warrants to the original purchaser only that the Goods will be free from defects in material and manufacture for the applicable time periods stated below: (1) Major structural components for a period of ten (10) years from the date of shipment; (2) Non-Structural, Donaldson-built components and accessories including Donaldson Airlocks, TBI Fans, TRB Fans, Fume Collector products, Donaldson built electrical control components, and Donaldson-built Afterfilter housings for a period of twelve (12) months from date of shipment; and (3) Donaldson-built filter elements for a period of eighteen (18) months from date of shipment.

Buyer is solely responsible for determining if goods fit Buyer's particular purpose and are suitable for Buyer's process and application. Seller's statements, engineering and technical information, and recommendations are provided for the Buyer's convenience and the accuracy or completeness thereof is not warranted. If, after Seller receives written notice, within the warranty period, that any goods allegedly do not meet Seller's warranty, and Seller, in its sole discretion, determines that such claim is valid, Seller's sole obligation and Buyer's exclusive remedy for breach of the foregoing warranty or any Seller published warranty, will be, at Seller's option, either: (i) repair or replacement of such goods or (ii) credit or refund to Buyer for the purchase price from Seller. In the case of repair or replacement, Seller will be responsible for the cost of shipping the parts but not for labor to remove, repair, replace or reinstall the allegedly defective goods. Refurbished goods may be used to repair or replace the goods and the warranty on such repaired or replaced goods shall be the balance of the warranty remaining on the goods which were repaired or replaced. Any repair or rework made by anyone other than Seller is not permitted without prior written authorization by Seller, and voids the warranty set forth herein. Seller warrants to Buyer that it will perform services in accordance with the Sales Documents using personnel of required skill, experience and qualifications and in a professional and workmanlike manner in accordance with generally recognized industry standards for similar services. With respect to any services subject to a claim under the warranty set forth above, Seller shall, in its sole discretion, (i) repair or re-perform the applicable services or (ii) credit or refund the price of such services at the pro rata contract rate and such shall be Seller's sole obligation and the exclusive remedy for breach of the foregoing warranty on services. Products manufactured by a third party ("Third Party Product") may constitute, contain, be contained in, incorporated into, attached to or packaged together with, the goods. Buyer agrees that: (a) Third Party Products are excluded from Seller's warranty in this Section 7 and carry only the warranty extended by the original manufacturer, and (b) Seller's liability in all cases is limited to goods of Seller's design and manufacture only. EXCEPT FOR SELLER'S WARRANTY OF TITLE TO THE GOODS, SELLER EXPRESSLY DISCLAIMS AND EXCLUDES ALL OTHER WARRANTIES WHATSOEVER, WHETHER, EXPRESSED OR IMPLIED, ORAL, STATUTORY, OR OTHERWISE, INCLUDING BUT NOT LIMITED TO MERCHANTABILITY, FITNESS FOR A PARTICULAR PURPOSE, NON-INFRINGEMENT OF THIRD PARTY INTELLECTUAL PROPERTY AND ANY WARRANTIES ARISING FROM TECHNICAL ADVICE OR RECOMMENDATIONS, COURSE OF DEALING OR OF PERFORMANCE, CUSTOM OR USAGE OF TRADE. Seller's obligations do not cover normal wear and tear or deterioration, defects in or damage to any goods resulting from improper installation, accident or any utilization, maintenance, repair or modification of the goods, or any use that is inconsistent with Seller's instructions as to the storage, installation, commissioning or use of the goods or the designed capabilities of the goods or that, in its sole judgment, the performance or reliability thereof is adversely affected thereby, or which is subjected to abuse, mishandling, misuse or neglect or any damage caused by connections, interfacing or use in unforeseen or unintended environments or any other cause not the sole fault of Seller, and shall be at Buyer's expense. Seller's warranty is contingent upon the accuracy of all information provided by Buyer. Any changes to or inaccuracies in any information or data provided by Buyer voids this warranty. Seller does not warrant that the operation of the goods will be uninterrupted or error-free, that the functions of the goods will meet Buyer's or its customer's requirements unless specifically agreed to, or that the goods will operate in combination with other products selected by Buyer or Buyer's customer for its use.

The terms of this warranty may only be modified by a special warranty document signed by a Director, General Manager or Vice President of Donaldson. To ensure proper operational performance of your equipment, use only genuine Donaldson replacement parts.

Significantly improve the performance of your collector with genuine Donaldson Torit replacement filters and parts.

Important Notice: Many factors beyond the control of Donaldson can affect the use and performance of Donaldson products in a particular application, including the conditions under which the product is used. Since these factors are uniquely within the user's knowledge and control, it is essential the user evaluate the products to determine whether the product is fit for the particular purpose and suitable for the user's application. All products, product specifications, availability and data are subject to change without notice, and may vary by region or country.



astgroup.ca



AST GROUP
OF COMPANIES

905-821-8860

