

COMPACT, COMPLETE, CONVENIENT

DOWNFLO® EVOLUTION PRE-ASSEMBLED LARGE DUST COLLECTOR

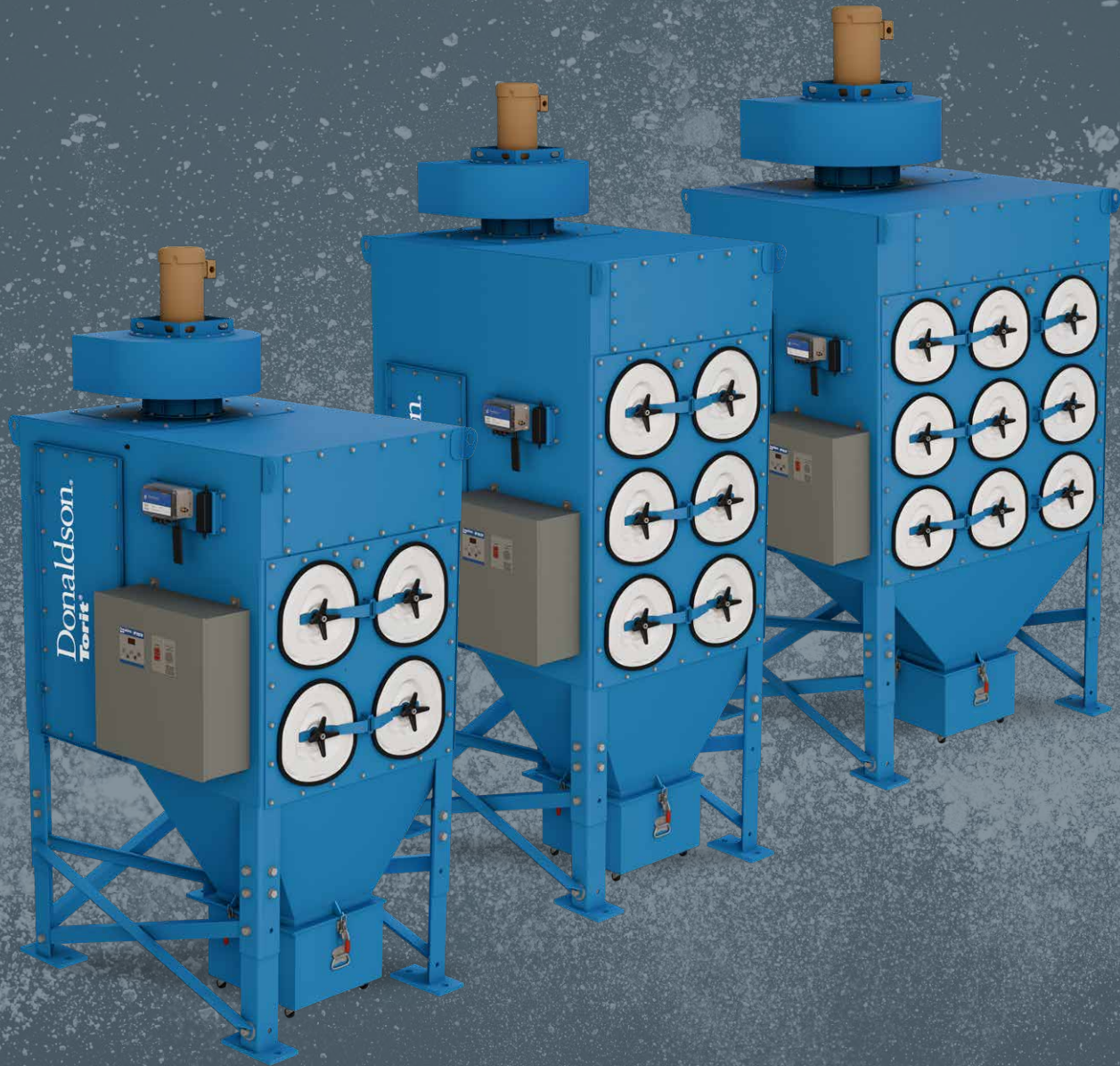

Donaldson
FILTRATION SOLUTIONS



Smart Collector
Powered by iCue™ Technology



PRODUCTIVITY MEETS PRACTICALITY

Today's advanced manufacturing tools operate in faster-paced environments, which is great for helping you meet your production goals, but can add a lot of dust to your work environment.

The Downflo® Evolution Pre-assembled Large (DFPRE) series of collectors was designed as a packaged system to answer customer demand for a compact, convenient, and reliable filtration system that can help maximize production uptime in non-combustible dust applications. The result is a family of innovative, easy-to-install dust collectors – DFPRE 4, 6 and 9 – engineered to provide advanced filtration performance and operational confidence.

Keep your operation moving at top speed – while managing the dust that comes with productivity – with effective and reliable dust management solutions that can support:



EHS Programs



Production Uptime



Economical Cost of Ownership



Packaged & Easy Installation

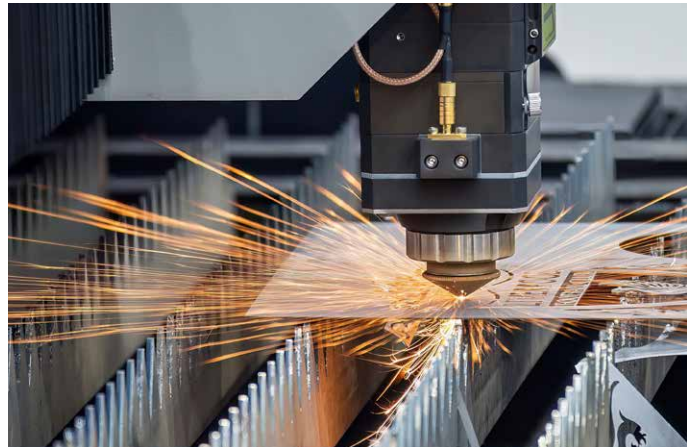

APPLICATIONS

Donaldson offers effective dust control solutions for your continuous manufacturing processes:

- Laser Cutting
- Metal Cutting
- Metal Fabrication

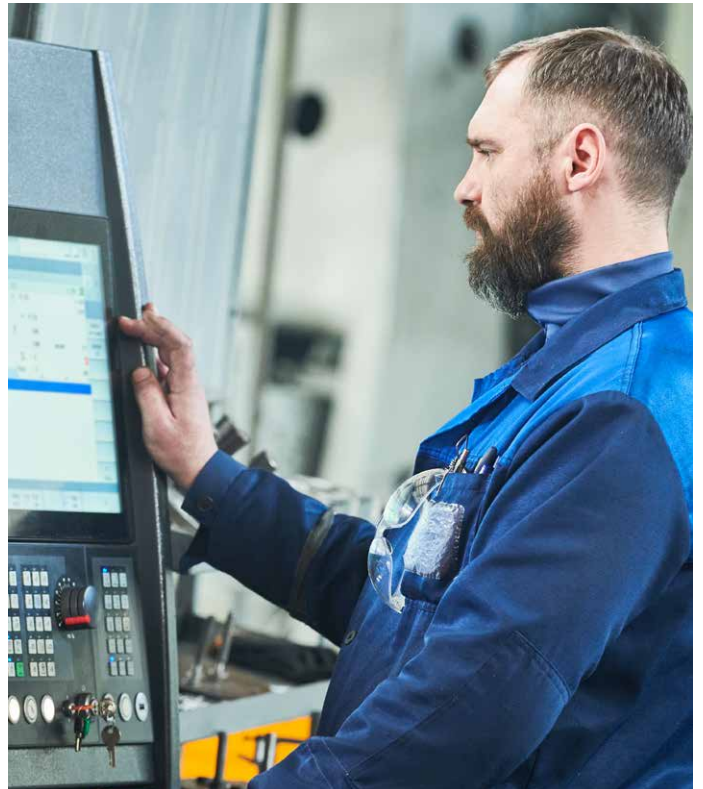



INNOVATIONS IN DUST CONTROL

For more than 40 years, Donaldson has been at the forefront of cartridge filter collection and has developed game-changing dust control solutions that are designed to support performance, convenience, and total cost of ownership.

Smart Collector

This Smart Collector comes standard with Donaldson's iCue™ Connected Filtration Technology. It monitors your equipment and provides operational insights through automated alerts and a dashboard that's accessible from your computer or smart device.

Spark Reducing Inlet

When incorporated as part of an overall fire mitigation strategy, it can help reduce the risk of a spark entering the dust collector by directing the airstream through a tortuous path via the low-side air inlet.*

**Intended for use in applications with an increased fire risk and can be used as part of an overall fire mitigation strategy. No single spark mitigation device, including the Spark Reducing Inlet, can guarantee the elimination of all sparks and ignition sources from entering the dust collector. Please contact your Donaldson sales representative to discuss additional fire mitigation strategies as necessary.*

DFPRE SERIES: DESIGNED TO PERFORM

These advancements have resulted in next-generation dust control systems. With a DFPRE collector, you'll discover:

Peak Performance

The air path and horizontal filter design allow for downward airflow in the dirty air plenum and enable optimal dust dropout.

Clean Processes

An optional airflow damper for quick airflow adjustments, as well as an optional backdraft damper to eliminate backflow of contaminant during downtime cleaning.

Cost Savings

The optional Spark Reducing Inlet helps reduce filter load and prolong filter life by pre-separating larger particles.



ENGINEERED TO EXCEL

The DFPRE 4, 6 and 9 utilize natural downward airflow for increased filtration performance. By ducting the dirty air into the collector from above the filters, the downward airflow forces heavy particulate from the airstream into the hopper.

The collector's horizontally mounted filters make filter changeouts easy and even help limit exposure to dust during the process. The filter orientation also contributes to reduced compressed air usage since most of the heavy particulate has already found its way to the containment vessel.

The unit's pre-wired fan and controls help take you from installation to operation fast, while the timely pulse cleaning adds to filter life and performance.

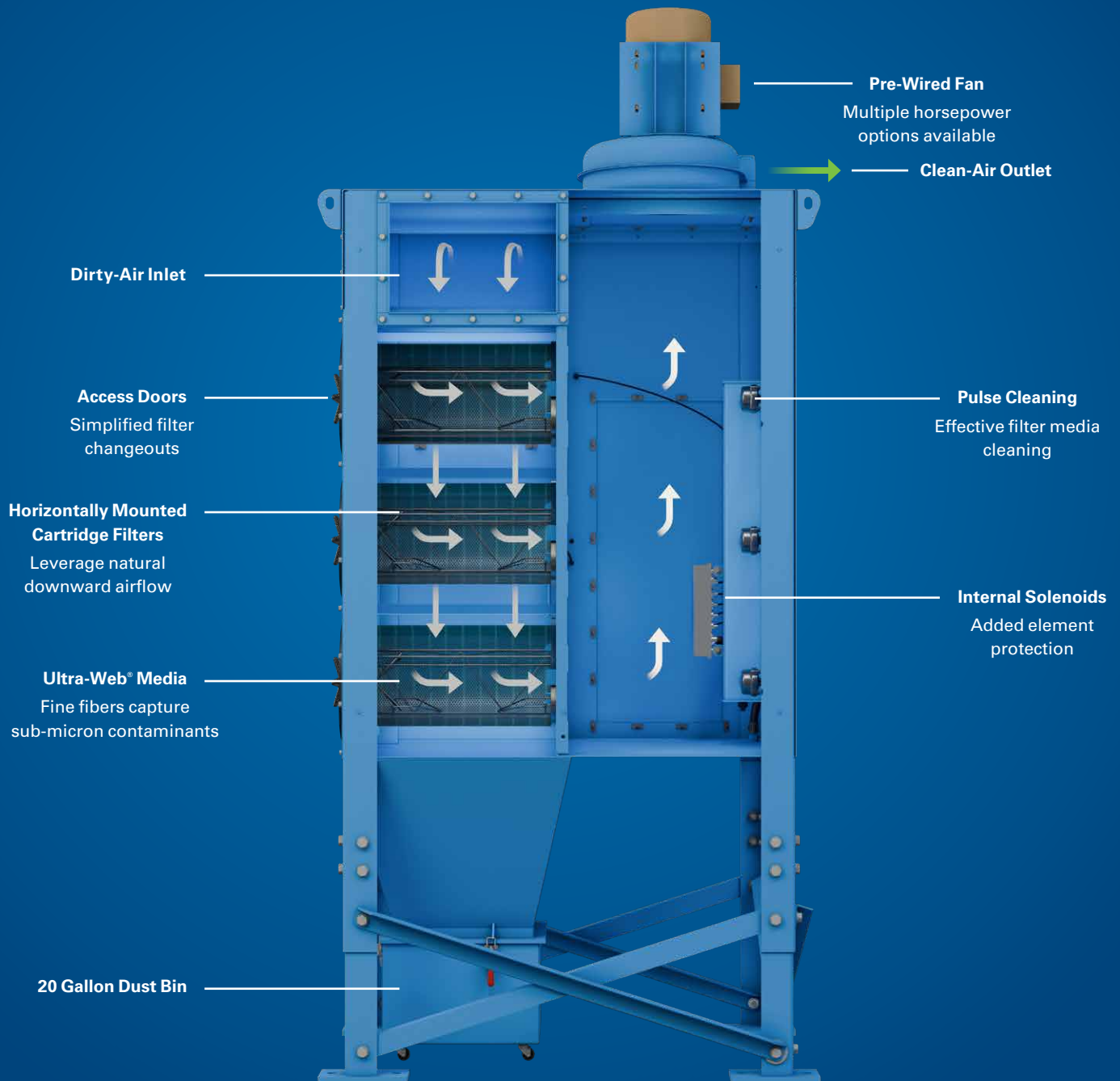

INDUSTRY-LEADING FILTRATION DESIGN

Our unique triagonal cartridge filters – made with industry-leading Ultra-Web® fine fiber filtration technology – have more filter media at the bottom of the cartridge element so pulse-cleaning energy directs the ejected dust toward its ultimate destination – the containment vessel.

Ultra-Web filtration technology features a layer of fine fibers (0.2 - 0.3 microns in diameter) on the surface of the media to capture sub-micron contaminants. This makes the dust cake come off easily during automated cleaning cycles, ensuring cleaner air longer.



Fine Fiber Media (600px) – Fine fiber surface loading technology is available in all Ultra-Web® and Fibra-Web® filter cartridges.

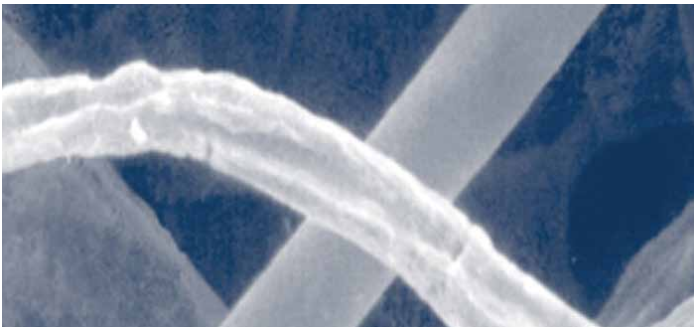

Commodity Filter Media (600px) – Conventional media has spaces of up to 60 µm between fibers, allowing dust to become deeply embedded.

With its efficient cartridge filters and advanced downward airflow, the DFPRE requires fewer filters for the same filtration power, resulting in:

- Reduced filter replacement costs
- Reduced maintenance
- Reduced floor space requirements

Triagonal filters are specifically designed for improved pulse cleaning, increased airflow per cartridge, and superior performance over traditional round filters.

In addition, Donaldson's DFPRE filters are placed strategically within the collector to allow for easy and fast filter replacement, and they are sized to avoid allowing the filter to exceed 50 pounds when loaded with dust. Convenient access panels allow operators to manage contaminant during changeouts.

Triagonal Filter

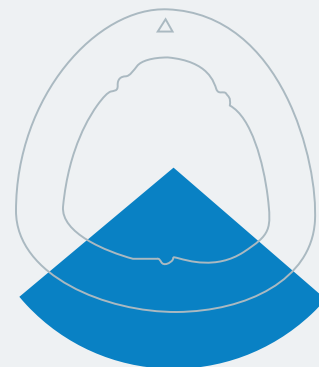

27% of Total Filter Media

Round Filter



25% of Total Filter Media

DIMENSIONS FOR THE DFPRE 4

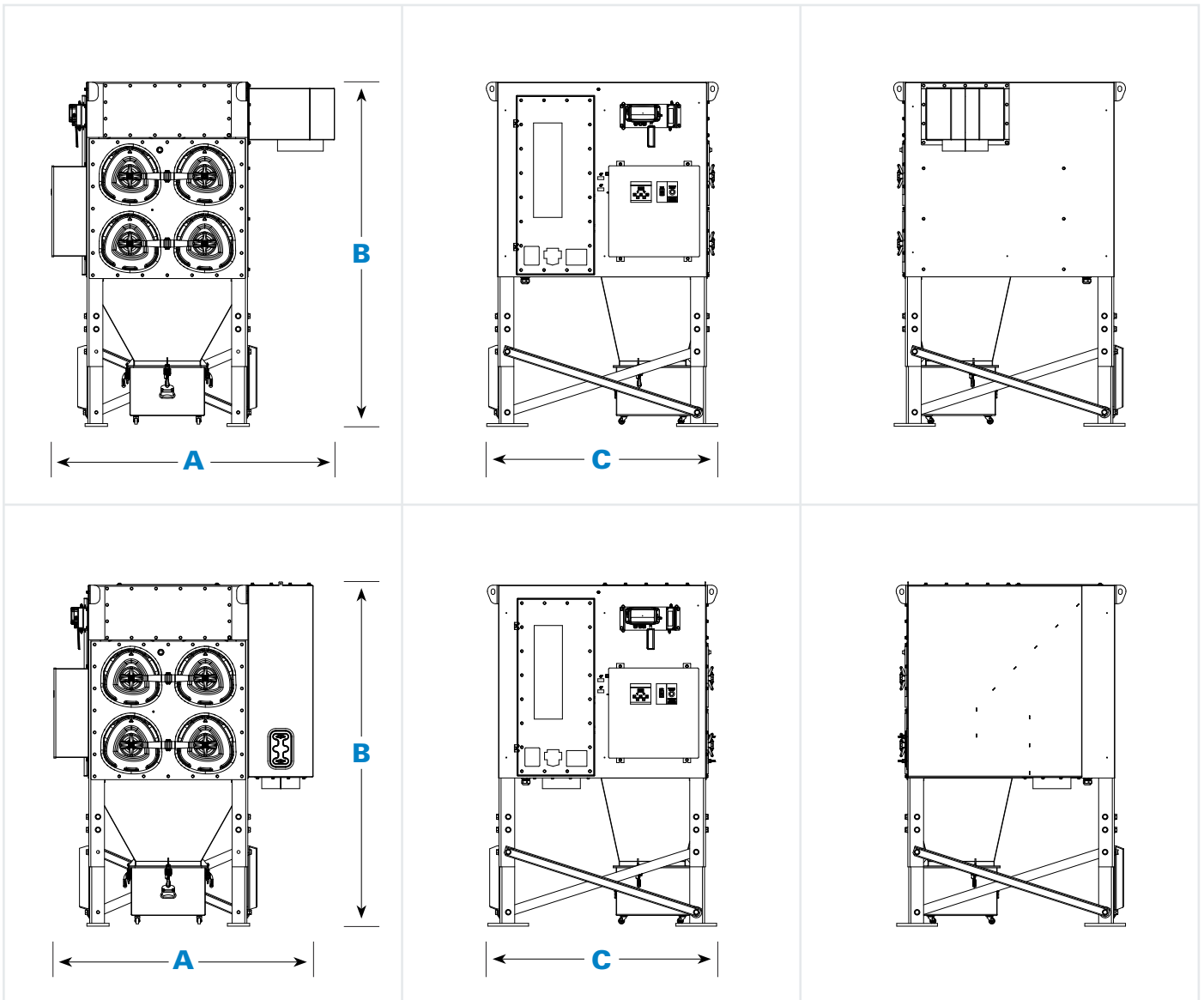

Model	Number of filter elements	Filter media (ft²)	Number of valves	Dimensions (mm)*			Weight (kg)**
				Width A	Height B	Depth C	
DFPRE 4	4	1,016	4	75.5" (1917.7)	92" (2336.8)	62" (1574.8)	1,458 lbs. (663)
DFPRE 4 with Spark Reducing Inlet				70" (1778)	92" (2336.8)	62" (1574.8)	1,713 lbs. (779)

* Without accessories or optional equipment. Dimensions & Weights depend on the options chosen.

** Weights include filter cartridges and are for collectors prior to first use, i.e., with no dust collected. Excludes shipped loose items.

DIMENSIONS FOR THE DFPRE 6

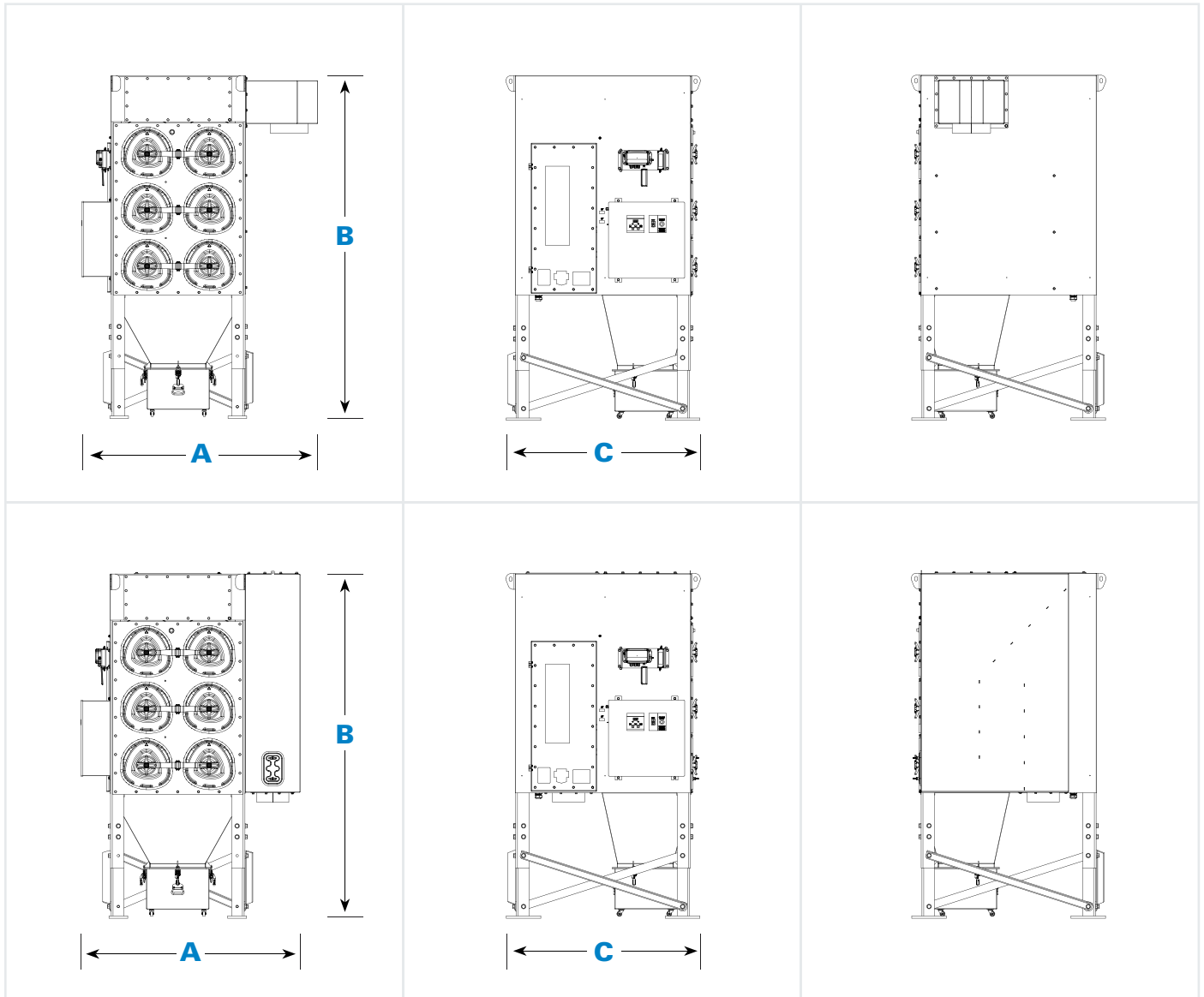

Model	Number of filter elements	Filter media (ft²)	Number of valves	Dimensions (mm)*			Weight (kg)**
				Width A	Height B	Depth C	
DFPRE 6	6	1,524	6	75.5" (1917.7)	110" (2794)	62" (1574.8)	1,753 lbs. (797)
DFPRE 6 with Spark Reducing Inlet				70" (1778)	110" (2794)	62" (1574.8)	2,088 lbs. (949)

* Without accessories or optional equipment. Dimensions & Weights depend on the options chosen.

** Weights include filter cartridges and are for collectors prior to first use, i.e., with no dust collected. Excludes shipped loose items.

DIMENSIONS FOR THE DFPRE 9

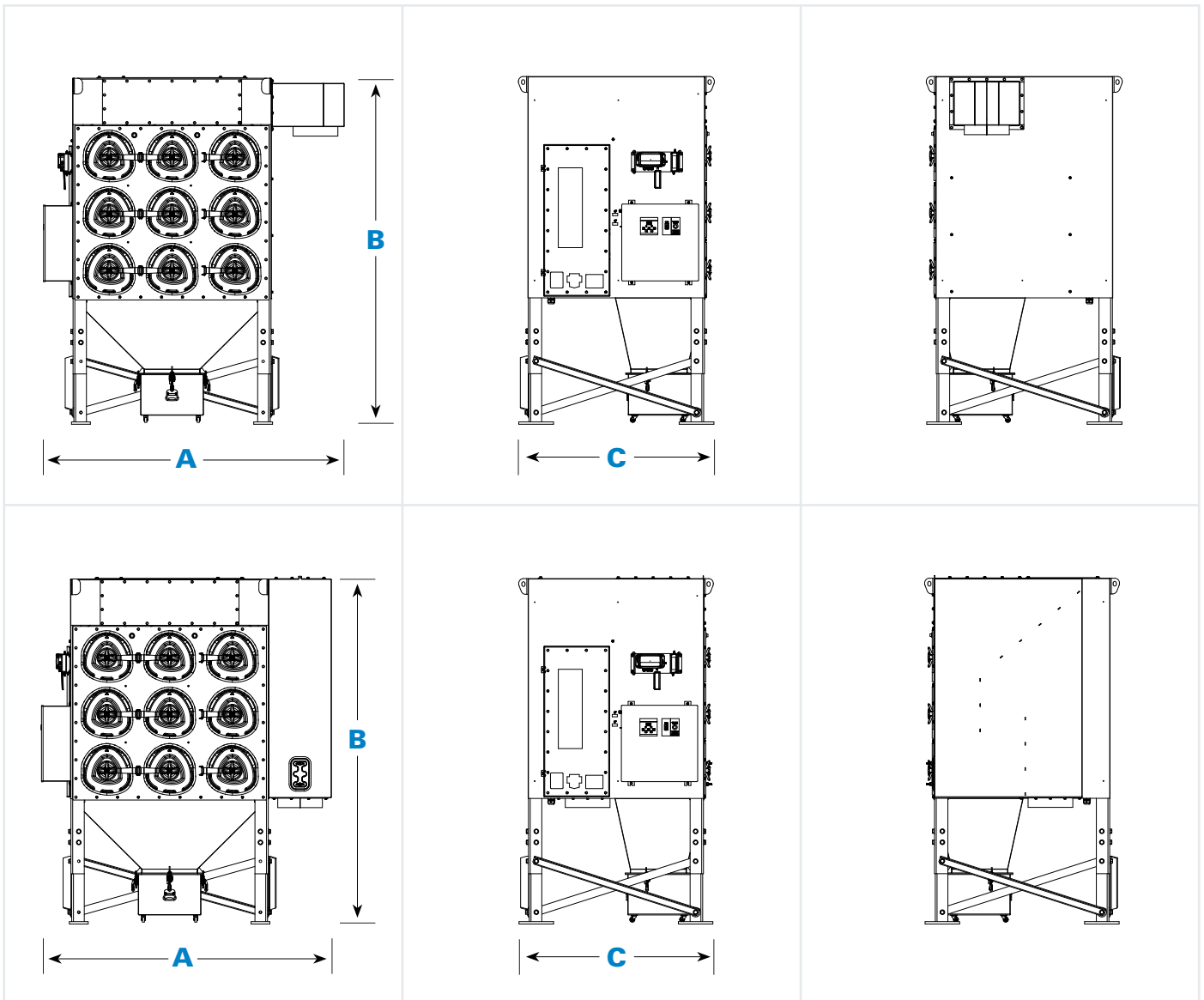

Model	Number of filter elements	Filter media (ft ²)	Number of valves	Dimensions (mm)*			Weight (kg)**
				Width A	Height B	Depth C	
DFPRE 9	9	2,286	9	95.5" (2425.7)	110" (2794)	62" (1574.8)	2,446 lbs. (1112)
DFPRE 9 with Spark Reducing Inlet				92.5" (2349.5)	110" (2794)	62" (1574.8)	2,803 lbs. (1274)

* Without accessories or optional equipment. Dimensions & Weights depend on the options chosen.

** Weights include filter cartridges and are for collectors prior to first use, i.e., with no dust collected. Excludes shipped loose items.

FEATURES & OPTIONS FOR THE DFPRE 4, 6 & 9

Collector Features	Std	Opt
Mild Steel Construction	X	
Filter Cleaning System	X	
Hinged Quick Removal Access Covers	X	
Straight Edge Inlet	X	
Easy Duct™ Inlet		X
Abrasive Resistent Inlet		X
Spark Reducing Inlet		X
Chamber Silencer		X
TBI Fan	X	
TRB Fan		X
Airflow Damper		X
HEPA Afterfilter		X
Sprinkler Taps	X	
Sprinkler Packs		X
Ultra-Web® Fine Fiber Media	X	
Other Media Options		X
10-Year Warranty	X	
Paint System	Std	Opt
Prime Coated Interior	X	
Textured Multi-Coat Paint Finish	X	
Custom Colors		X
Premium Duty Finish		X
Epoxy Coating		X

Hopper Discharge	Std	Opt
20 gal Dust Container	X	
55 gal Dust Drum		X
Electrical Controls, Gauges & Enclosures	Std	Opt
Control Box with Delta P and Motor Starter	X	
Control Box with Delta P+ and Motor Starter		X
Remote Mounted Controls		X
Donaldson's iCue™ Connected Filtration Technology	X	

Sound Testing					
Fan Model TBI	Fan Speed (rpm)	No Silencer LP dBA	With Exhaust Silencer		
			Fan Case/Motor LP dBA	Exhaust Only LP dBA	Quiet Cov-R LP dBA
3	3500	86	77	69	60
5	3500	88	79	68	60
7.5	3500	93	83	70	65
10	3500	89	80	75	68
15	3500	93	82	77	67
20	3500	95	84	77	71
25	3500	95	85	74	71
30	3500	96	85	74	71

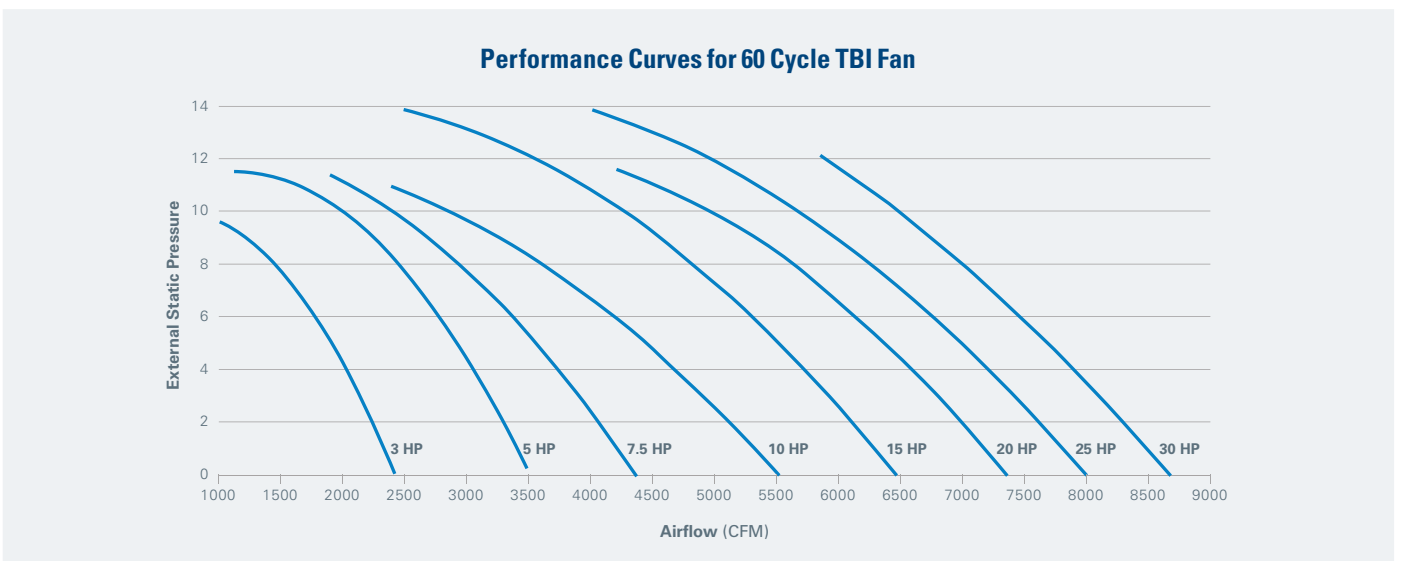

SMART COLLECTOR. SMART CHOICE.

Choosing a Donaldson Smart Collector means choosing an industry-leading dust, fume, and mist collection solution for your operation and employees.

Smart Collectors come equipped with Donaldson's iCue™ Connected Filtration Technology. The system tracks your equipment, providing real-time data and analytics to help maximize uptime, increase maintenance efficiency, and manage your operation's critical compliance data. Our industry professionals, extensive product portfolio, and outstanding service and support make your Smart Collector a Smart Choice.

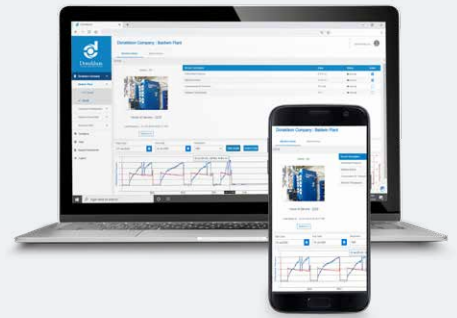

**UNPARALLELED
PERFORMANCE**



**INNOVATIVE FILTER
MEDIA TECHNOLOGY**



**INTELLIGENT
ENGINEERING**



Smart Collector
Powered by iCue™ Technology



Donaldson.

astgroup.ca



905-821-8860

