

Installation and Operation Manual

CI Rotary Valve



This is the safety alert symbol. It is used to alert you to potential personal injury hazards. Obey all safety messages that follow this symbol to avoid possible injury or death.

Illustrations are for reference only as actual product may vary.

This manual is property of the owner. Leave with the unit when set-up and start-up are complete. Donaldson Company reserves the right to change design and specifications without prior notice.

⚠ DANGER ROTATING BLADES COULD CAUSE SERIOUS INJURY

LOCK OUT power before servicing this equipment.

Keep hands, feet, and loose clothing away from both inlet and outlet openings to avoid injury or damage when valve is operating.

Both the inlet and outlet of the rotary valve should be attached to an enclosure or have a guard in place to prevent hands, feet, or loose clothing from entering the valve.

Operate rotary valve only when all guards are correctly and securely in place.

It is not unusual for rotary valves to be operated from a remote location, so rotary valves may start unexpectedly. LOCK OUT power before servicing any rotary valves.

This manual contains specific precautionary statements relative to worker safety. Read this manual thoroughly and comply as directed. Instruct all personnel on the safe use and maintenance procedures related to this equipment. Discuss any questions on the application, use, or maintenance of this equipment with a Donaldson Torit representative.

For optimum performance, use only Donaldson Torit replacement parts.

Graphic Location and Graphic Previews

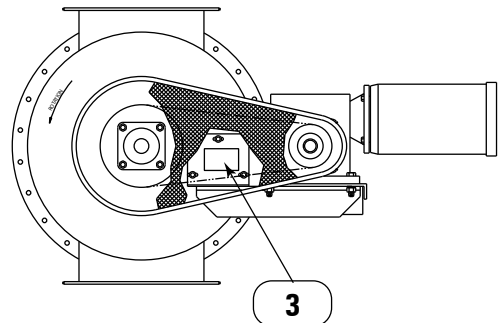
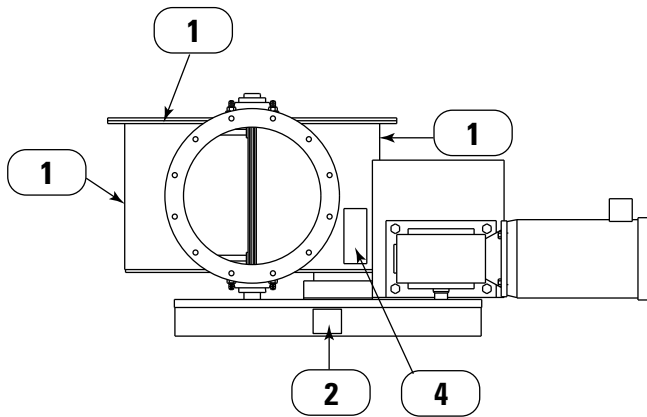

1

⚠ DANGER

Keep hands away from any moving parts.

Turn power off and LOCK OUT electrical services before removing any guards to perform maintenance work.

Disconnect drive before performing any airlock maintenance.

NEVER place hands in airlock.

2

⚠ DANGER

Keep hands away from any moving parts.

Turn power off and LOCK OUT electrical services before removing any guards to perform maintenance work.

Disconnect drive before performing any airlock maintenance.

3

⚠ DANGER

If you can read this sign, a guard has been removed. DO NOT operate with guard removed.

4

<p>⚠ WARNING</p> <p>Failure to follow instructions may result in severe personal injury, death, and/or product or property damage.</p> <p>DO NOT operate this equipment until you have read and understand the instructions and warnings in the Installation and Operation Manual.</p> <p>For a replacement manual, contact Donaldson Company, Inc. (800) 365-1331.</p> <p>Use equipment for its originally intended use ONLY.</p> <p>DO NOT modify equipment.</p> <p>DO NOT remove or deface this label.</p> <p>Replace label if damaged. For a new label, contact Donaldson Company, Inc. (800) 365-1331.</p>	<p>⚠ PRECAUTION</p> <p>El no seguir estas instrucciones puede causarle algun daño y hasta la muerte o bien dañar el producto o bienes de su propiedad.</p> <p>NO opere este equipo hasta que haya leído y comprendido las instrucciones y advertencias del manual de instalación y operación.</p> <p>Para obtener un manual de partes de repuesto por favor contacte a Donaldson Company, Inc. (800) 365-1331.</p> <p>El equipo debe ser utilizado para lo que fue diseñado unicamente.</p> <p>NO modifique el equipo.</p> <p>NO remueva o quite esta etiqueta.</p> <p>Reemplazar en caso de daño. Para conseguir una nueva etiqueta contacte a Donaldson Company, Inc. (800) 365-1331.</p>
--	--

Contents

Description.....	1	Preliminary Start-Up Check.....	7
Purpose and Intended Use	2	Maintenance Information.....	8
Operation.....	2	Operational Checklist	8
Inspection on Arrival.....	3	6" and 8" CI Axial Rotor Adjustment	9
Installation Codes and Procedures.....	3	10" and 12" CI Axial Rotor Adjustment	10
Hoisting Information	3	Troubleshooting.....	11
Electrical Wiring	4	Service Notes.....	13
Installation	4		
Reducer.....	4		
Electrical Connection	5		
Optional Equipment.....	6		



DANGER indicates a hazardous situation which, if not avoided, will result in death or serious injury.



WARNING indicates a hazardous situation which, if not avoided, could result in death or serious injury.



CAUTION, used with the safety alert symbol, indicates a hazardous situation which, if not avoided, could result in minor or moderate injury.



NOTICE is used to address practices not related to personal injury.

Data Sheet

Model Number _____	Serial Number _____
Ship Date _____	Installation Date _____
Customer Name _____	
Address _____	
Filter Type _____	
Accessories _____	
Other _____	

Description

The CI Rotary Valve can be used as an airlock or feeder on conveying systems and dust collection equipment. The CI Rotary Valve is a heavy duty high capacity machined valve with cast housing and end plates, and a fabricated machined rotor. The end plates have outboard sealed bearings with packing gland shaft seals and an air purge tap connection (for an optional air seal using plant air). The housing and end plates are typically cast iron with optional nickel or chrome plating. The housing also contains a vent fitting that can be connected to a surge hopper or other suitable device for venting any pressure leakage across the rotor. The rotor is available in 3 styles – fixed, adjustable tip and flex tip blade. The fixed and adjustable tip blades are also available with plain ends or beveled ends with optional hard-facing or cutter blades. In addition,

the adjustable tip blades can have mild steel or a variety of rubber tips. The flex tip rotor has 6 non adjustable lighter duty rubber wipers that extend beyond the metal rotor blades on 3 sides. On the flex tip design, a rubber wiper is attached to each rotor pocket creating a double wiper tip on the perimeter of each rotor blade. The valve is rated for a maximum pressure differential of 12 psi between the inlet and outlet on steel tipped blades and up to approximately 4 psig for adjustable tipped blades. The flex tip rotor valves are rated for a maximum pressure differential of 17" w.c. An auxiliary drive motor, gear reducer, and chain drive with sprockets can be ordered for the CI Rotary Valve. Standard drive packages are capable of providing a range of rotor speeds from 15-22 rpm.

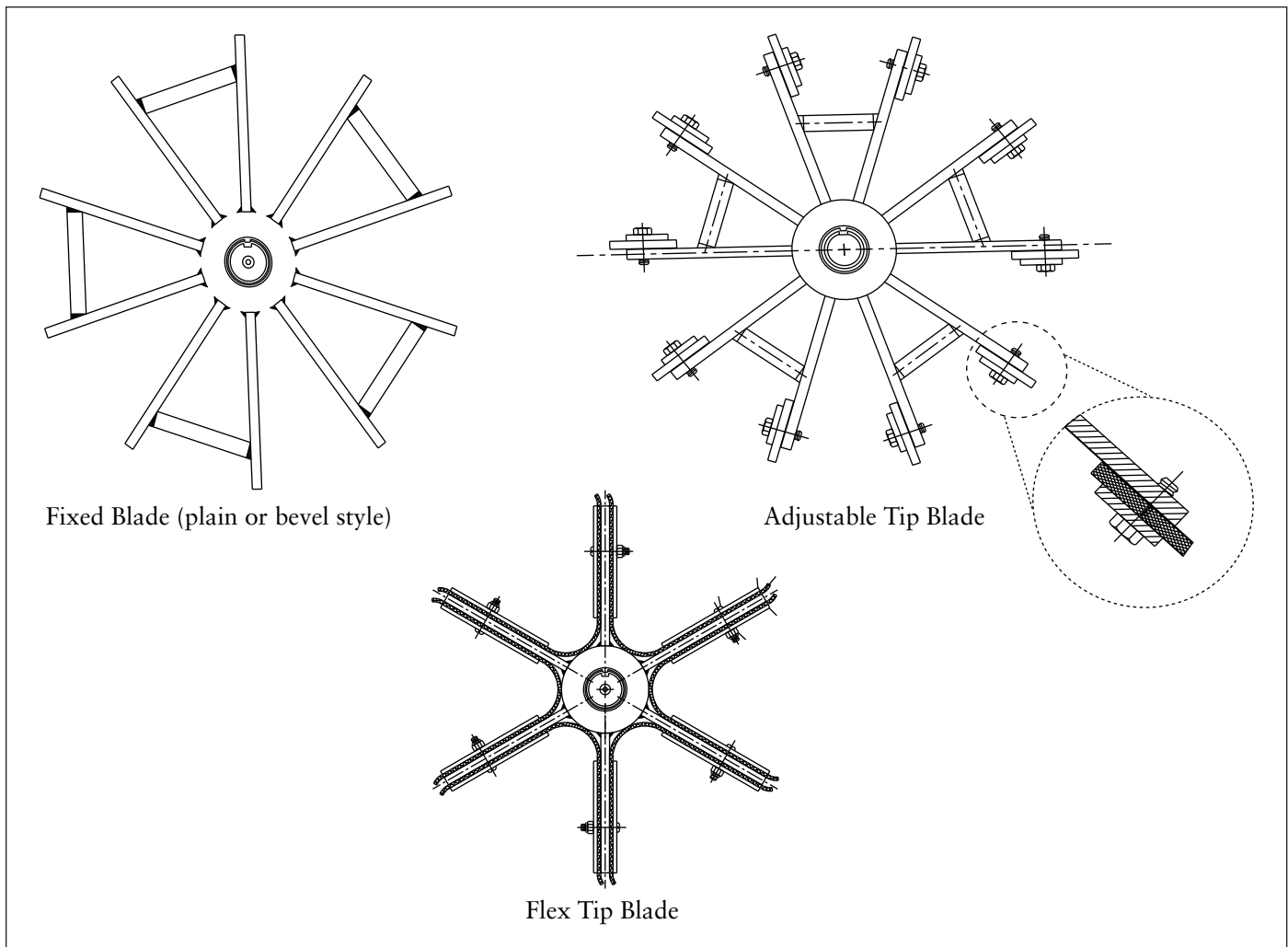

Rotor Styles

Purpose and Intended Use

WARNING

Misuse or modification of this equipment may result in personal injury.

Do not misuse or modify.

The CI valve is typically used as an airlock and/or feeder on a pneumatic conveying or dust collection system. It allows continuous discharge of dust or particulate through the valve while maintaining an air seal between the valve inlet and outlet. It can also be used as a product metering device especially when controlled by a variable speed drive.

The valve has been used on numerous dry particulate applications including wood, grain and solid chemicals. However, as each application is unique, various valve modifications may be required for proper operation including custom rotor/housing clearances, and various blade materials and configurations like beveled and cutter blades, etc. We encourage you to talk with your Donaldson Torit representative for assistance in selecting a rotary valve for your requirements.

Operation

Rotary valves are used as an airlock and/or a metering device in dust control applications. When used as an airlock, the valve seals the dust collector hopper against the pressure difference between the hopper and the valve's outlet while allowing dust or material to pass through.

During normal operation, the valve rotor rotates inside the housing at 22-rpm. Particulate or dust enters the inlet flange and falls into each rotor pocket as it rotates. The material is discharged by gravity as each rotor pocket passes the outlet flange.

When used as a metering device, the valve allows a specific amount of material to pass per revolution, depending on the size and speed of the valve. Most valves are sized for 40-60% pocket fill.

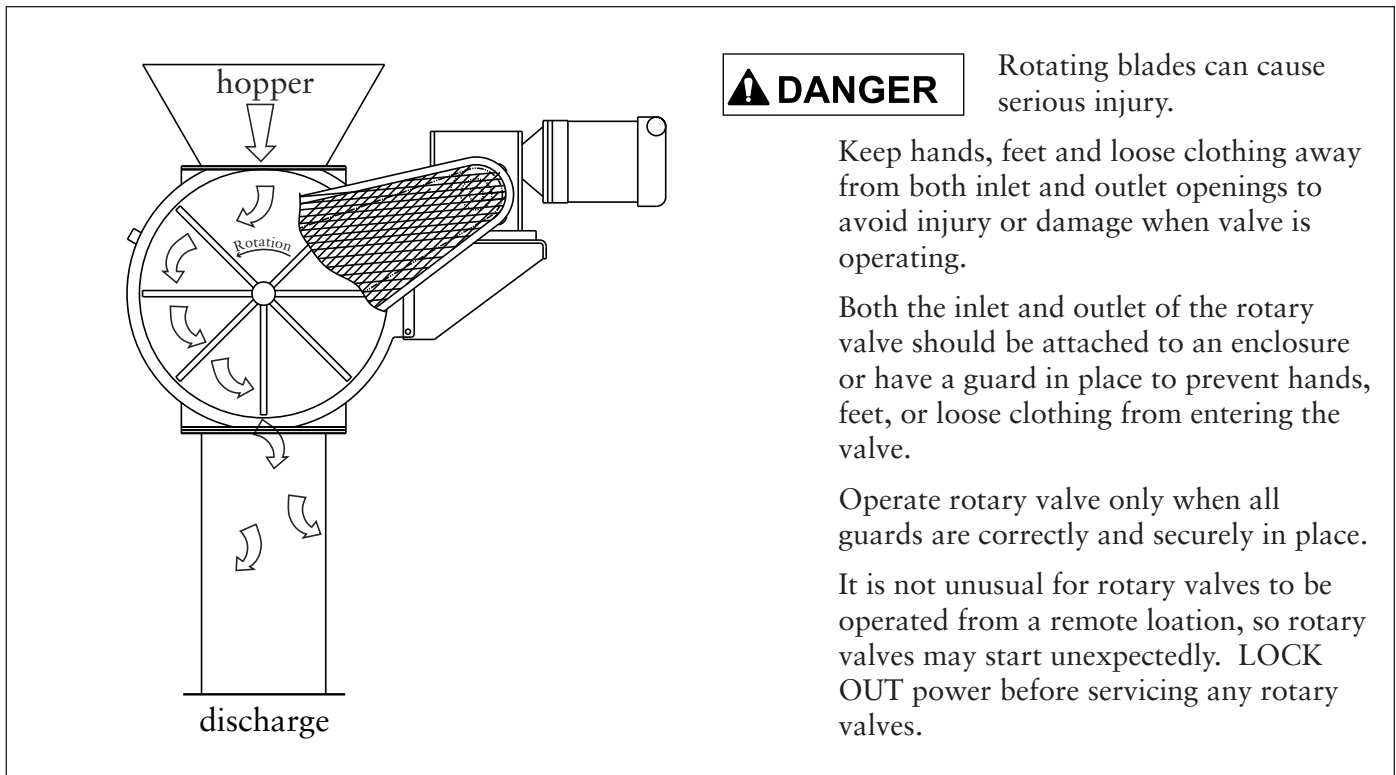

DANGER

Rotating blades can cause serious injury.

Keep hands, feet and loose clothing away from both inlet and outlet openings to avoid injury or damage when valve is operating.

Both the inlet and outlet of the rotary valve should be attached to an enclosure or have a guard in place to prevent hands, feet, or loose clothing from entering the valve.

Operate rotary valve only when all guards are correctly and securely in place.

It is not unusual for rotary valves to be operated from a remote location, so rotary valves may start unexpectedly. LOCK OUT power before servicing any rotary valves.

Rotary Valve Operation

Inspection on Arrival

1. Inspect valve crating and packaging on delivery for any signs of damage or mishandling such as broken seal wrap, damaged crating, etc.

NOTICE

The valve has precision machined components with close tolerances. Improper handling could cause the machined parts to shift and internal parts may become misaligned.

2. Report any damage to the delivery carrier. If unseen damage is suspected, check the valve clearances between the rotor and housing or operate the valve on a workbench to listen for any binding between the rotor and housing. The rotor blade should turn freely without rubbing on the valve housing (except for flex tip rotor blades). See Maintenance Information for more information on checking and adjusting the valve clearances.
3. Request a written inspection report from the Claims Inspector to substantiate claim.
4. File claims with the delivery carrier.
5. Compare unit received with description of product ordered.
6. Report incomplete shipments to the delivery carrier and your Donaldson representative.
7. Remove crates and shipping straps. Remove loose components and accessory packages before lifting unit from truck.

Installation Codes and Procedures

Safe and efficient operation of the unit depends on proper installation.

Authorities with jurisdiction should be consulted before installing to verify local codes and installation procedures. In the absence of such codes, install unit according to the National Electric Code, NFPA No. 70-latest edition and NFPA 91 (NFPA 654 if combustible dust is present).

A qualified installation and service agent must complete installation and service of this equipment.

All shipping materials, including shipping covers, must be removed from the unit prior to, or during unit installation.

NOTICE

Failure to remove shipping materials from the unit will compromise unit performance.

Inspect unit to ensure all hardware is properly installed and tight prior to operating valve.

Hoisting Information

Suggested Tools & Equipment

Clevis Pins and Clamps	Lifting Slings
Crane or Forklift	Screwdrivers
Drift Pins	Wrenches
End Wrench Sockets	

WARNING

Failure to lift the valve correctly can result in severe personal injury or property damage.

Use appropriate lifting equipment and adopt all safety precautions needed for moving and handling the equipment.

A crane or forklift is recommended for unloading and installation of the valve.

Location must be clear of all obstructions, such as utility lines or roof overhang.

Use all lifting points provided.

Use clevis connectors, not hooks, on lifting slings.

Check the Specification Control drawing for weight and dimensions of the valve and components to ensure adequate crane capacity.

Allow only qualified crane operators to lift the equipment.

Refer to applicable OSHA regulations and local codes when using cranes, forklifts, and other lifting equipment. Lift unit and accessories separately, and assemble after unit is in place.

Use drift pins to align holes in flanges during assembly.

Electrical Wiring

WARNING

Electrical installation must be performed by a qualified electrician and comply with all applicable national and local codes.

Turn power off and lock out electrical power sources before performing service or maintenance work.

Do not install in classified hazardous atmospheres without an enclosure rated for the application.

All electrical wiring and connections, including electrical grounding, should be made in accordance with the National Electric Code, NFPA No. 70-latest edition.

Check local ordinances for additional requirements that apply.

The appropriate wiring schematic and electrical rating must be used. See unit's rating plate for required voltage.

If the unit is not furnished with a factory-mounted disconnect, an electric disconnect switch having adequate amp capacity shall be installed in accordance with Part IX, Article 430 of the National Electrical Code, NFPA No. 70-latest edition. Check unit's rating plate for voltage and amperage ratings.

Refer to the wiring diagram for the number of wires required for main power wiring and remote wiring.

Installation

DANGER

Rotating blades can cause serious injury.

Turn power off and lock out electrical sources before performing service.

Keep hands, feet, and loose clothing away from both inlet and outlet openings to avoid injury or damage when valve is operating.

Use a soft probe, NOT your hand, to rotate the valve rotor when inspecting the pockets and wipers of the rotor.

1. Remove the protective plastic wrap, hardboard inlet cover, and flange gaskets shipped with the valve.

2. Inspect the valve pockets for foreign material and check that the wipers are securely fastened to the rotor backup plates (if applicable).
3. Determine the proper position required for the rotary airlock. Allow clearance for electrical connections and future maintenance.

NOTICE

Companion flanges must be true and square to rotary valve flanges and of sufficient size to support valve weight. Otherwise additional valve support will be required.

4. Place the sponge-rubber flange gasket on the airlock's top flange.
5. Fasten the rotary valve to the dust collector's hopper flange using 3/8-16 bolts and washers. Tighten hardware alternately in steps. Avoid over tightening.
6. Install a discharge spout or guard to the rotary valve outlet flange using 3/8-16 bolts and washers. Tighten hardware alternately in steps. Avoid over tightening.

Reducer

NOTICE

Check reducer oil level before operating the valve.

1. Fill the reducer to the level indicated with oil of the proper viscosity. Refer to the reducer installation lubrication and operation instructions provided with the valve for oil viscosity and oil change recommendations. In the absence of this information, use Mobil® SHC 634 synthetic lubricant for operating ambient temperature range of -30° C to 125°F.
2. Check that vent caps, drain, and fill plugs are installed and secure.

CAUTION

Consult the petroleum supplier for lubricants that are acceptable to the Food and Drug Administration and other regulating agencies when installing in food and drug industries, including animal foods.

Electrical Connection



Rotating blades can cause serious injury.

Turn power off and lock out electrical power sources before performing service or maintenance work.

Standard valve motors are wired for 208-230/460-Volt, 3 phase, 60 Hz operation.

1. Install a customer-supplied motor starter with a low voltage control circuit for the valve motor.
2. Using the wiring diagram supplied, wire the valve motor and motor starter. Use appropriate wire gauge for the rated amp load as specified by local codes.
3. Turn the valve motor ON then OFF to check for proper rotation by referencing the rotation arrow located on the valve.



Do not look into valve outlet to determine rotation.

Material may unexpectedly be discharged from the valve. View the valve rotation through the back of the motor or from the front of the drive guard.

To reverse rotation, three-phase power supply:

Turn electrical power OFF at source and switch any two leads on the output-side of the motor starter.



Do not interchange a power lead with the ground wire.

Severe damage or personal injury may result.

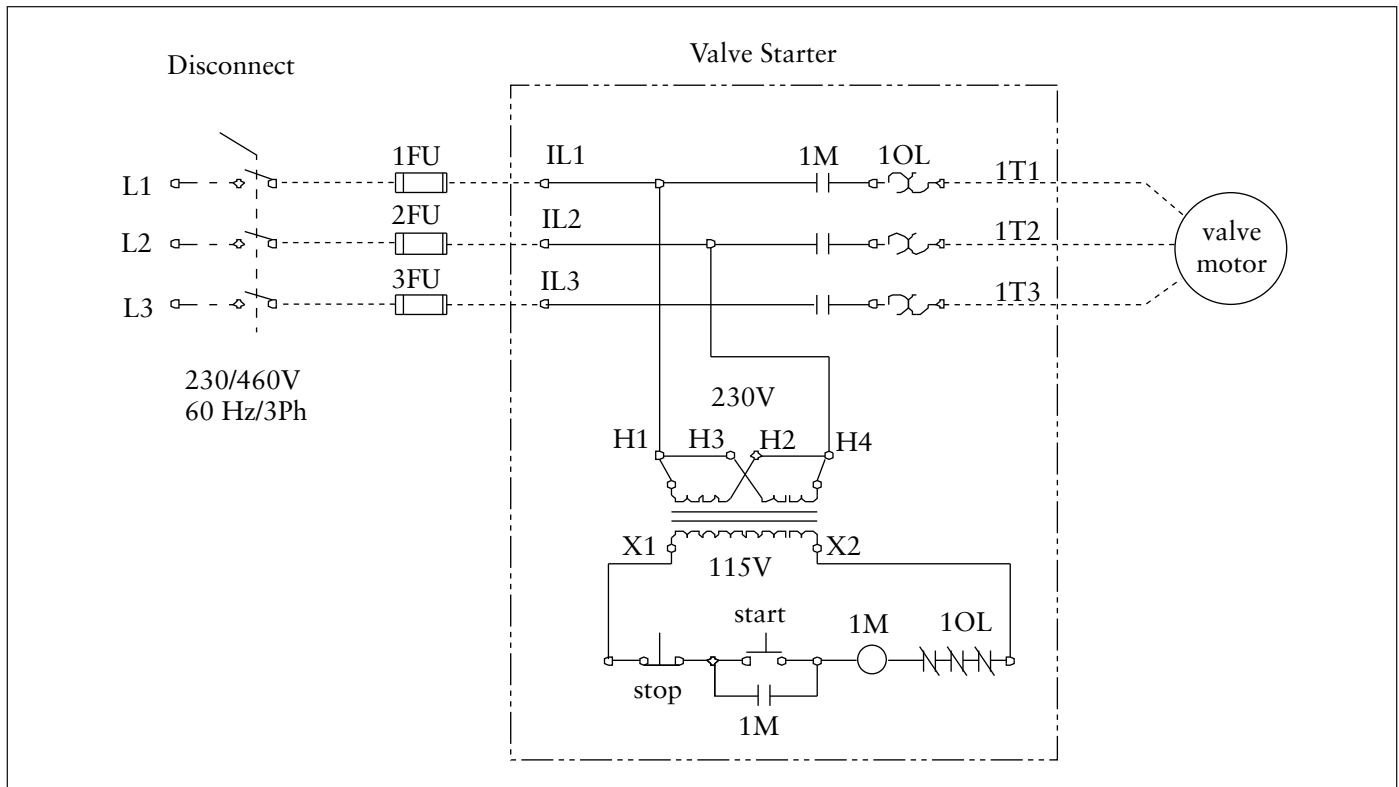

Typical CI Rotary Valve Wiring Diagram

Optional Equipment

- Stainless steel housings
- Nickel or chrome plated cast iron housings
- 8 or 12 blade rotors (except on flex tip style)
- Beveled, cutter, or hard faced blades
- Adjustable tip blade rotor with above options or a variety of rubber tips
- Flex tip 6 blade rotor with a variety of rubber wipers
- Speed switches
- Housing vent plug adapter (for attaching to vent hose)
- Slow speed drives
- Explosion proof motors

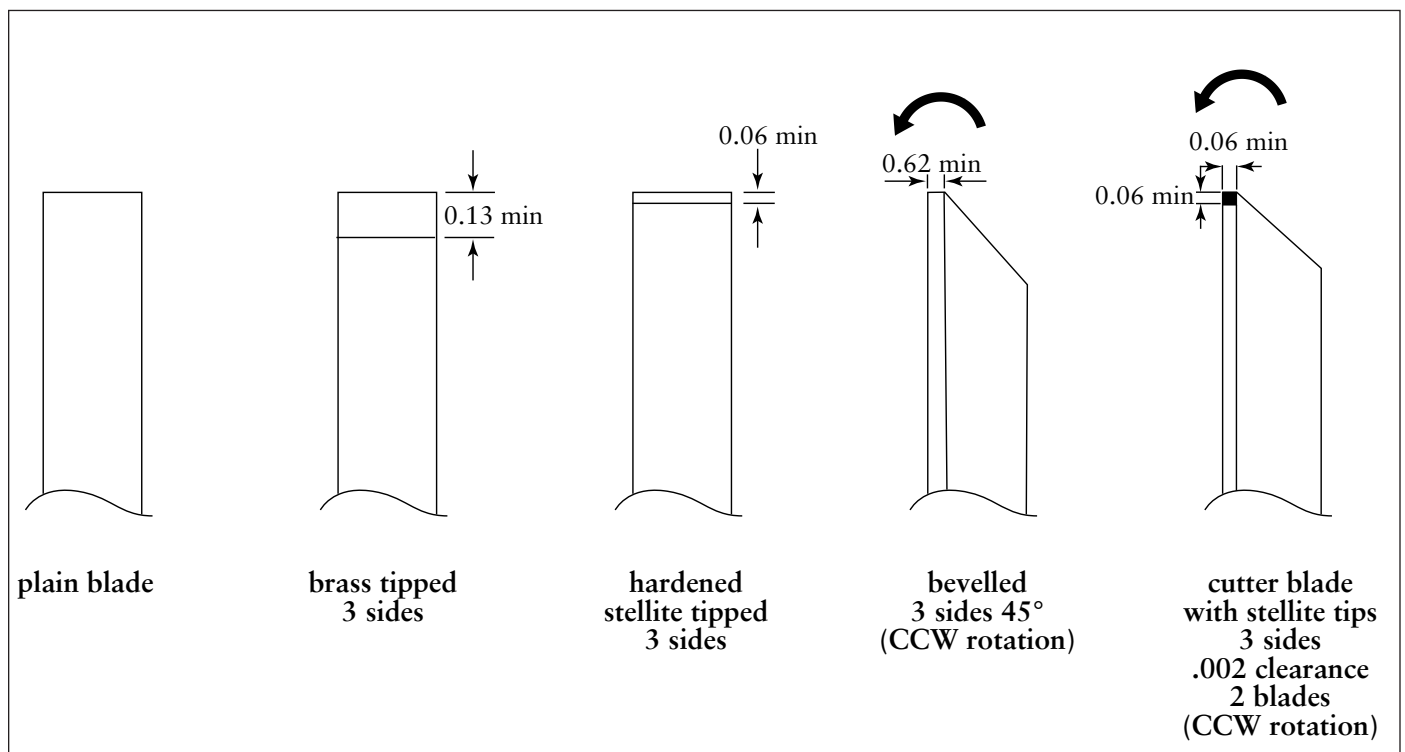

Blade Tip Options

Preliminary Start-Up Check

Instruct all personnel on safe use and maintenance procedures.

⚠ DANGER Rotating blades can cause serious injury.

Turn power off and lock out electrical power sources before performing service or maintenance work.

Keep hands, feet and loose clothing away from both inlet and outlet openings to avoid injury or damage when valve is operating.

⚠ WARNING Electrical installation must be performed by a qualified electrician and comply with all applicable national and local codes.

Check that the valve is clear and free of all debris before starting.

Do not install in classified hazardous atmospheres without an enclosure rated for the application.

1. Check all electrical connections for tightness and contact.
2. Check for and remove all loose items in or near the inlet and outlet of the unit.
3. Check that all remote controls are wired into the control system, and all service switches are in the OFF position.
4. Check that all optional accessories are installed properly and secured.
6. Check the oil level in the reducer and that the vent plugs are in place and secure.
6. Check that the drive guard is in place and secure.
7. Turn power (service switch) ON at source.
8. Turn the rotary valve motor ON then OFF to check for proper rotation by referencing the rotation arrow located on the valve endplate.

⚠ DANGER Rotating blades can cause serious injury.

Keep hands, feet and loose clothing away from both inlet and outlet openings to avoid injury or damage when valve is operating.

⚠ WARNING Do not look into valve outlet to determine rotation. Material may unexpectedly be discharged from the valve. View the valve rotation through the back of the motor or from the front of the drive guard.

To reverse rotation, three-phase power supply:

Turn electrical power OFF at source and switch any two leads on the output-side of the rotary valve motor starter.

⚠ WARNING Do not interchange a power lead with the ground wire. Severe damage or personal injury may result.

9. Check that valve operation does not disrupt upstream or downstream equipment.
10. Operate valve for 10 to 15 minutes and inspect housing for hot spots or unusual noises.
11. Turn upstream equipment ON to run product through the valve. Continue to inspect housing for hot spots or noises.

NOTICE If the valve discharges into a conveying system, the conveying system should also be operating to prevent overfilling the conveying system.

12. Check motor amp draw to verify that valve is not being overloaded.
13. Check product flow-rate if valve is used as a metering device.

Maintenance Information

Instruct all personnel on safe use and maintenance procedures.

DANGER

Rotating blades can cause serious injury.

Keep hands, feet and loose clothing away from both inlet and outlet openings to avoid injury or damage when valve is operating.

WARNING

Electrical installation must be performed by a qualified electrician and comply with all applicable national and local codes.

Turn power off and lock out electrical power sources before performing service or maintenance work.

Do not install in classified hazardous atmospheres without an enclosure rated for the application.

Operational Checklist

1. Monitor the physical condition of the valve and repair or replace any damaged components.
Routine inspections will minimize downtime and maintain optimum system performance. This is particularly important on continuous-duty applications.
Periodically check the valve for proper operation by observing and listening to it under normal operation. If problems are noticed, see the Troubleshooting section.
2. Monitor the pressure drop across the valve.
Abnormal changes in pressure drop indicate a change in operating conditions and possibly a fault to be corrected.
3. Monitor particulate feed rate if applicable.
4. Make sure dust/particulate is not bridging above the valve inlet. See the Troubleshooting section if this occurs.
5. Periodically check the packing gland shaft seals for dust leakage. If leakage is noticed, adjust the packing gland shaft compression by tightening the 5/16" bolts on the packing gland follower plate (see 6" and 8" Axial Rotor Adjustment).

NOTICE

Do not over tighten as excessive packing gland wear and rotor friction will occur.

If leakage still occurs after tightening, new packing may be required.

6. Note, only the axial rotor clearances can be adjusted (by re-centering the rotor) unless the rotor has adjustable tips. If the rotor valve clearances need checking or adjusting, this should only be done by a trained and qualified mechanic using the following suggested procedure:
 1. Shut down the dust or conveying system.
 2. Lock out all electric power to the valve.
 3. If the valve is difficult to access or in an unsafe area, remove from the system and bring to workshop.
 4. Wear safety glasses and protective clothing, respirators, etc. as appropriate. Consult your company's material safety data sheet and take appropriate additional precautions before cleaning or working on the valve.
 5. Remove the valve chain guard and the drive chain by disconnection of the chain connection link.

DANGER

Checking rotor clearances may require hands inside the valve body. To avoid possible severe injury, block the rotor so it cannot accidentally turn while hands are in the body of the valve. For example, inserting a large wood block in the valve inlet can prevent the rotor from turning.

6. Check the rotor side to end plate clearances with a feeler gage. The standard clearances on most valves are 0.004 - 0.007", but may vary on custom applications or rotors with cutter blades. Check the order documentation and valve drawing for confirmation of the required clearances. The clearances should be checked along the entire edge of each rotor blade noting any variance exceeding 0.002". Record the average clearance on each blade end to determine if the rotor needs centering in the housing. Excessive variance on or between each blade may indicate the need for a new rotor.

To adjust the axial rotor clearance, use one of the following procedure based on valve size.

6" and 8" CI Axial Rotor Adjustment

1. Pry off bearing cover caps with a screwdriver from each endplate.
2. Loosen lock tab washers over bearing lock nut on each endplate by prying up lock tabs.
3. On the side with tight clearance, loosen (counterclockwise rotation) the bearing lock nut slightly.
4. On the side with excessive clearance, tighten (clockwise rotation) the lock nut (pulling the rotor towards you) until the rotor is centered in the housing.

5. Retighten the bearing locknut that was loosened so it is snug against the bearing.

NOTICE

Do not over tighten. After tightening the lock nut, the rotor should manually turn relatively freely, but not continue to rotate when stopped.

6. Tighten the lock tab washers over each bearing lock nut by tapping down the lock tabs.
7. Reassemble the bearing cover caps.

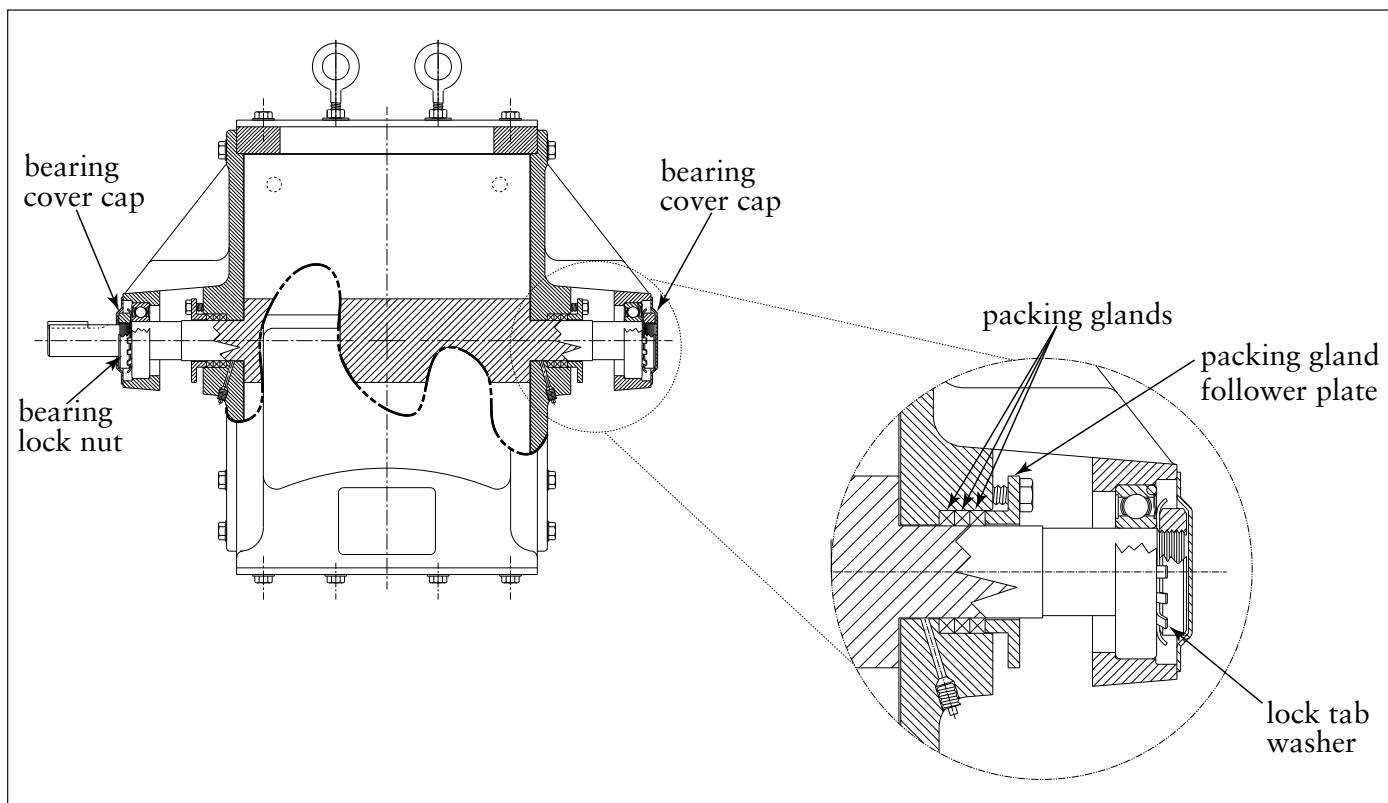

6" and 8" Axial Rotor Adjustment

10" and 12" CI Axial Rotor Adjustment

1. Loosen the bearing retainer flathead lock screws on each endplate as shown in Detail A.
2. With a spanner wrench, loosen the bearing retainer (counterclockwise rotation) a few turns on the endplate that has excessive clearance. See Detail B.
3. On the opposite endplate, shift the rotor by tightening (clockwise rotation) the bearing retainer until the rotor is centered in the valve housing.
4. Retighten the bearing retainer that was loosened so it is snug against the bearing.
5. Retighten the flathead lock screws on each endplate bearing retainer.
6. Reassemble the drive chain and guard.

NOTICE Do not over tighten. After tightening the retainer, the rotor should manually turn relatively freely, but not continue to rotate when stopped.

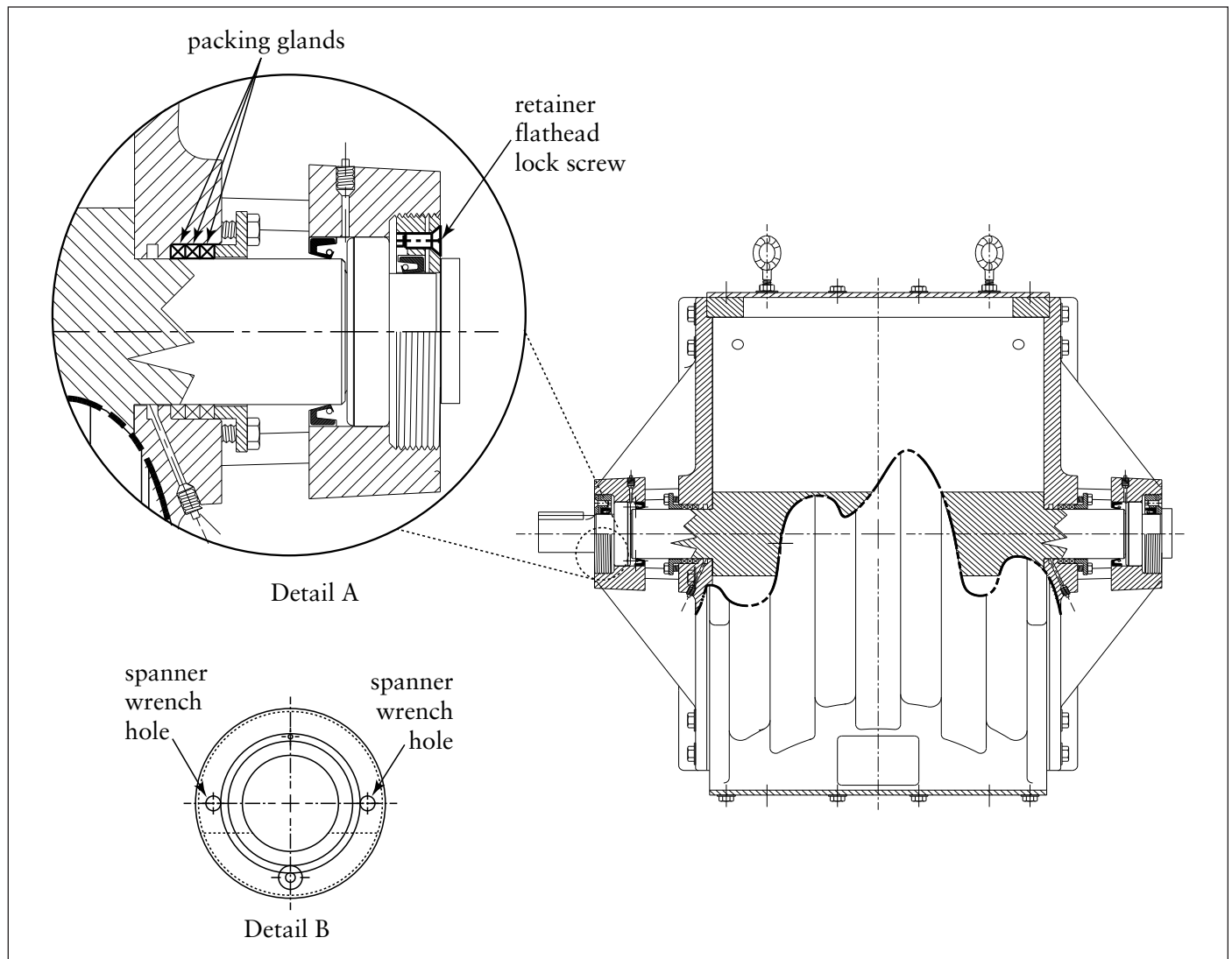

10" and 12" Axial Rotor Adjustment

Troubleshooting

Problem	Probable Cause	Remedy
Valve rotor does not turn freely, binds, or chatters	Rotor not centered in valve housing	Center rotor.
	Particulate or foreign object caught between rotor and housing	Reverse rotor to remove object. If this does not work, remove valve from service and disassemble.
	Too much particulate feed to valve inlet	Reduce feed rate or use larger valve size.
	Excessive particulate caking on valve housing	Remove excessive moisture or use rotor with beveled blades and two cutter blades and/or coated valve housing.
Excessive particulate caking on valve housing	Excessive moisture in product.	Remove excessive moisture from upstream particulate or use rotor with beveled blades and two cutter blades and/or coated valve housing.
	Rotor may be turning in the wrong direction (for beveled blades)	Reverse valve rotation.
Motor stops running	Improper fuse or breaker size	Check fuse or breaker size required based on motor FLA rating.
	Motor improperly wired (or for wrong voltage)	Check motor wiring per diagram on motor nameplate.
	Wrong voltage supplied to motor	Check motor nameplate.
	Safety interlock activated	Check control panel wiring to motor.
	See probable causes above for valve rotor does not turn freely, binds, or chatters	See remedies above for valve rotor does not turn freely, binds, or chatters.
Motor runs but valve not turning	Reducer problem	Check reducer operation.
	Broken or misaligned drive chain, sprocket, or shaft key	Inspect drive components and adjust or repair.
Particulate bridges above valve inlet	Particulate not free flowing	May need steeper inlet hopper or anti-bridging devices like bin flow areators or vibrator.
	Light particulate and/or high pressure differential across valve rotor	Connect the valve housing air vent to a surge hopper above valve or a dust control suction line.
	Excessive rotor/housing clearances	Install new rotor with tighter tolerances (reduced clearance).

Problem	Probable Cause	Remedy
Valve endplates or housing are hot	See probable causes above for valve rotor does not turn freely, binds, or chatters	See remedies above for valve rotor does not turn freely, binds, or chatters.
	Bad bearings	Replace or lube bearings.
Dust leaks outside valve	Loose inlet/outlet or end plate flange connections	Tighten as required.
	Packing glands loose or worn	Tighten or replace packing glands.

This Page Intentionally Left Blank

The Donaldson Torit Warranty

Donaldson warrants to the original purchaser that the major structural components of the goods will be free from defects in materials and workmanship for ten (10) years from the date of shipment, if properly installed, maintained and operated under normal conditions. Donaldson warrants all other Donaldson built components and accessories including Donaldson Airlocks, TBI Fans, TRB Fans, Fume Collector products, Donaldson built electrical control components and Donaldson built Afterfilter housings for twelve (12) months from date of shipment. Donaldson warrants Donaldson built filter elements to be free from defects in materials and workmanship for eighteen (18) months from date of shipment. Donaldson does not warrant against damages due to corrosion, abrasion, normal wear and tear, product modification, or product misapplication. Donaldson also makes no warranty whatsoever as to any goods manufactured or supplied by others including electric motors, fans and control components. After Donaldson has been given adequate opportunity to remedy any defects in material or workmanship, Donaldson retains the sole option to accept return of the goods, with freight paid by the purchaser, and to refund the purchase price for the goods after confirming the goods are returned undamaged and in usable condition. Such a refund will be in the full extent of Donaldson's liability. Donaldson shall not be liable for any other costs, expenses or damages whether direct, indirect, special, incidental, consequential or otherwise. The terms of this warranty may be modified only by a special warranty document signed by a Director, General Manager or Vice President of Donaldson. Failure to use genuine Donaldson replacement parts may void this warranty. **THERE EXIST NO OTHER REPRESENTATIONS, WARRANTIES OR GUARANTEES EXCEPT AS STATED IN THIS PARAGRAPH AND ALL OTHER WARRANTIES INCLUDING MERCHANTABILITY AND FITNESS FOR A PARTICULAR PURPOSE, WHETHER EXPRESS OR IMPLIED ARE HEREBY EXPRESSLY EXCLUDED AND DISCLAIMED.**

astgroup.ca



AST GROUP
OF COMPANIES

905-821-8860



**Air Separation
Technologies Inc.**
astcanada.ca



AST
Engineering Inc.
astengineering.ca



AST
Mechanical Inc.
astmechanical.ca

STEVENSON SPRINKLER.ca
& Fire Protection Ltd.
stevensonssprinkler.ca



Donaldson
Filtration Solutions

Donaldson Company, Inc.
Industrial Air Filtration
P.O. Box 1299
Minneapolis, MN 55440-1299

Donaldson Company, Inc. is the leading designer and manufacturer of dust, mist, and fume collection equipment used to control industrial-air pollutants. Our equipment is designed to help reduce occupational hazards, lengthen machine life, reduce in-plant maintenance requirements, and improve product quality.