

Spark Detection and Extinguishing System

APPLICATIONS

The Raptor Spark™ Detection and Extinguishing System is an FM Approved safety device that is designed to detect and extinguish sparks and glowing embers that are traveling through a duct system. The hazard is detected by infrared sensors and extinguished with water spray nozzles within milliseconds of detection.

The Raptor Spark™ Detection control module has the capacity to receive hazard alert signals from multiple components (Dust Probes & Thermal Probes) and monitor multiple duct-zones and vessels.

The Raptor Spark™ Detection and Extinguishing System is an essential Fire Protection, Fire Isolation and Diversion device that is commonly installed with Raptor Gate™ High Speed Abort Gates, FireBreak Shutters, VIGILEX Explosion Vents and explosion certified VDL Rotary Valves. Typical automatic functions include hazard detection, system shut-down, isolation/abort, and extinguish and/or suppression.



CERTIFICATIONS & STANDARDS

FM Approved
 ATEX EN 1366-2, EN 13501
 CSI 1643FR, REI 120-RE 120
 CE



STANDARD FEATURES

- Output for Pre-Alarm
- Output for Alarm
- IP65 Enclosure
- Monitored inputs
- Alarm outputs
- Timed alarm outputs
- IP54

Raptor Spark™ Detection & Extinguishing Control Unit RS-PCUSP1L

The Raptor Spark Detection & Extinguishing Control Unit (RS-PCUSP1L) is designed to minimize the risk of fire and explosion in dust filtration and pneumatic conveying systems. This control unit communicates with a variety of components to monitor and protect a single zone with up to six components. **The Control Units, RS-PCU1610SD & RS-PCUSP1L, are FM Approved.**



Raptor Spark™ Extinguishing Assembly RS-EXT02

The Extinguishing Assembly (RS-EXT02) is designed to work in conjunction with the RS-CUSP1L control unit and RS-SD02 Spark Detectors. When the control module gets a signal that a hazard has been detected, the extinguishing assembly is activated. A water spray is initiated inside the piping system to extinguish sparks or glowing embers that could cause fire or explosion. **The Extinguishing Assembly (RS-EXT02) is FM Approved and ATEX Certified.**



Raptor Spark™ Dust Probe RS-DP03

The Dust Probe (RS-DP03) is a charge displacement probe that uses the principle of the displacement of the electric charge in the electrode. It signals the RS-PCUSP1L Control Unit when there is an increase in the concentration of dust levels which could potentially indicate the rupture or ineffective operation of dust filters and/or dust bags. **The Dust Probe (RS-DP03) is FM Approved and ATEX Certified.**



Raptor Spark™ Thermal Probe RS-TP02

The Thermal Probe (RS-TP02) is designed to work either as a thermovelocimetric output (rapid raise in temperature in a short amount of time), or as a thermostatic output (fixed temperature threshold) to alarm the RS-PCUSP1L Control Unit of potential fire hazards in the ductwork, dust collector units, hoppers, cyclones and etc. **The Thermal Probe (RS-TP02) is FM Approved and ATEX Certified.**

Raptor Spark™ Spark Detector RS-SD02

The **Spark Detector (RS-SD02)** is designed to work with the **RS-PCUSP1L Control Unit**. The **Spark Detector** uses advanced technology and circuit, sensitive to infrared light to detect sparks, flames, and incandescent material that passes in front of its optical element. The **Spark Detector (RS-SD02)** is **FM Approved and ATEX Certified**.



Raptor Spark™ Test Lamp RS-TL02

The **Test Lamp (RS-TL02)** is designed to work in association with the **Spark Detectors (RS-SD02)**. The **Test Lamp** provides a function check to ensure the cleanliness of the **Spark Detector** lenses by emitting high infrared radiation into ducting or pneumatic conveying lines across from the spark detectors to simulate a spark or glowing ember in the line. The **Test Lamp (RS-TL02)** is **FM Approved and ATEX Certified**.



Raptor Spark™ Firebreak Shutter EM-FBS

The **FireBreak Shutter** is engineered to isolate fires and fire hazards in process ventilation and dust collection applications. The **Fire Break Shutter** can be activated by the **RS-PCU1610SD Control Unit** or **RS-PCUSP1L** via **Spark Detection** or sensing activation by **Thermal Probe**.



Water Pressure Booster Pump RS-CPR

The **Raptor Spark™ Water Pressure Booster Pump RS-CPR** was designed to regulate water pressure going into the extinguishing unit. It is the best solution for facilities that have over or under pressure water lines available for installation of the **Spark Detection and Extinguishing System**.



APPLICATION AND GUIDELINES

Raptor Spark™
Dust Probe

Raptor Spark™
Thermal Probe

Raptor Spark™
FireBreak Shutter

Raptor Spark™
Alarm Bell

Raptor Spark™
Alarm Light

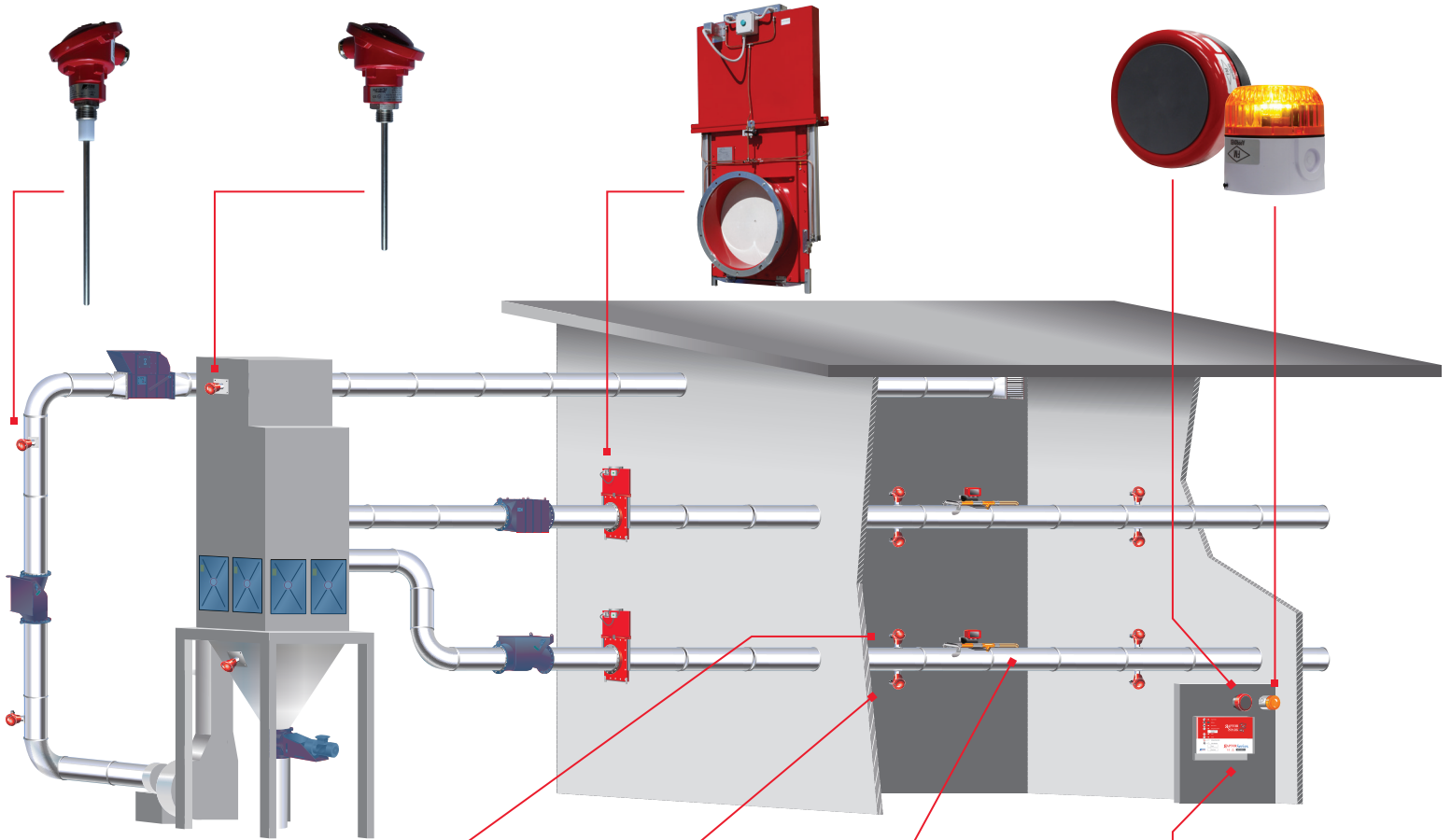

Raptor Spark™
Spark Detector
(Infrared Sensor)

Raptor Spark™
Test Lamp

Raptor Spark™
Extinguishing Assembly

Raptor Spark™
Spark Detection and
Extinguishing Control Unit