

In modern industrial plants where welding, grinding, machining or other processes produce potentially combustible dust, mist, or fume, maintaining a clean and safe work environment becomes a top priority. Assessing and addressing the fire risks in your facility should be part of your process hazard analysis and prevention plan.

The classic fire triangle consists of an ignition source, a fuel, and an oxidizer – all of which are needed to produce a fire. Unfortunately it is often easy to find all three in many manufacturing facilities around various dust collection points and in collectors. Sparks, heat, or embers from many processes can become ignition sources. The dust, fume, or mist being produced and collected may provide fuel. Air used to transport dust, fume, or mist to a collector then provides the last component, an oxidizer.

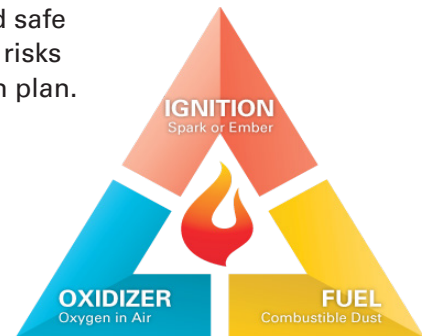

PREVENTION AND PROTECTION

Removing even one component from the fire triangle – ignition, fuel, or oxidizer – will prevent a fire from occurring. Process requirements often make elimination of combustible dust, mist, or fume impractical. Displacing the air (oxygen) is generally not feasible, so the prevention focus is often on ignition source mitigation in order to prevent fires. If a process cannot be adjusted or controlled to totally eliminate the risk of an ignition source and fire, then a protection strategy is the next key step.

Using smaller point-of-use collectors may reduce the amount of fuel present in the collector, but a fire may still occur and cause serious hazards in the area and risk to the plant. Quick detection and clean suppression of fires not only minimize damage to collectors but also reduce the risk of fire spreading to surrounding areas.

Carbon Dioxide fire suppression systems deliver clean, dependable suppression in seconds and can be incorporated into collection processes to provide effective fire protection.

FIRE SUPPRESSION SYSTEMS

High pressure Carbon Dioxide (HP CO₂) fire suppression systems are ideal for industrial processes where flammable materials and vapors present potential fire hazards. When fires occur in collectors they are considered “deep seated,” and HP CO₂ fire suppression systems are an effective and proven method for extinguishing such events.

Carbon dioxide is a low-cost material and harmless to equipment, as it leaves no residue and no clean-up is required. HP CO₂ fire suppression systems offer the flexibility to protect the smallest to the largest collector designs and are recognized by listing/approval fire protection agencies.



Kidde Fire Systems, a global leader in fire protection, and Donaldson have partnered to define fire suppression packages for many standard Donaldson Torit Collectors. These fire suppression packages include: a Kidde High Pressure CO₂ fire suppression system, an optional smoke detector, a Power Interrupt panel, and inlet/outlet fire dampers. Custom Kidde fire suppression packages for unique applications or collectors are also available.

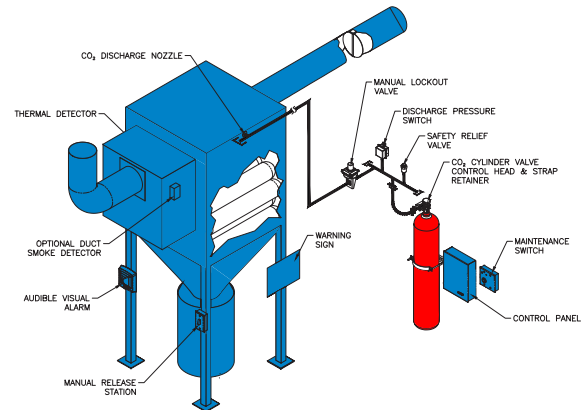

SYSTEM DESIGN AND OPERATION



HP CO₂ fire suppression systems are designed to minimize the impact from a fire to the collector and to the surrounding area. The HP CO₂ fire suppression system follows the design practices in NFPA 12, which calls for the flooding of a collector with CO₂ to a 75% concentration. The HP CO₂ fire suppression system typically uses one, two or three CO₂ cylinders piped to a discharge nozzle mounted in the collector or the inlet duct.

Thermal probes installed in the collector detect a rise in thermal heat which then activates the HP CO₂ fire suppression system. An optional clean air duct mounted smoke detector can be included as an early warning signal to alert personnel of potential issues prior to system activation.

Contacts on the Kidde Aegis Control Panel are available to tie into plant fire alarm systems to indicate system actuation or trouble conditions.

System restrictions:

- Not for use on Class D fires.
- Heat detector – selection based on maximum dust collector operating temperature
- CO₂ tanks – storage at ambient temperatures 0°F to 130°F
- Smoke detector – indoor installation only

Authorized Representative:



**Air Separation
Technologies Inc.**

336 Bronte Street S., Suite 222
Milton, ON L9T 7W6
T: 905-821-8860
F: 905-693-9401
www.astcanada.ca

